

Embedded Computing Enables Smart Grid Technology

By Mark Lovett, Chief Marketing Officer

America's electric grid has been in constant development since the late 1800s, fueled in large part by Thomas Alva Edison's invention of a commercially viable light bulb and Nikola Tesla's patents in the area of alternating current power generation. More than a century later, the continental grid consists of nearly 200,000 miles of transmission lines and is managed by some 500 companies.

The beauty of the grid is that power can be bought and sold across vast expanses, allowing for a more balanced supply and demand equation. Minor transmission failures in one section of the grid can also be compensated for by using electricity generated elsewhere. But the downside is that a more serious problem in one location can result in cascading failures and power outages covering a wider area.

Due to an expanding population, higher fuel costs and pollution related issues there has been a major push to develop an electrical grid that is more efficient, cost effective and robust. To a large degree, the idea of creating a smart grid is based on the use of embedded computers to monitor energy generation, transmission, distribution and usage, thus enabling more intelligent real-time decisions to be made.

The future grid will, by necessity, look much different than today. While past design decisions dealt with traditional sources of power based on gas, oil, coal and nuclear fuels, going forward the grid will need to accommodate the expanding use of wind, solar, biomass and geothermal generation. It will also have to address storage requirements in support of those energy sources with uneven power generation.

A critical shortcoming of the current grid infrastructure lies in the fact that control is largely performed by older Supervisory Control And Data Acquisition (SCADA) systems that don't work in harmony or even communicate with each other in a timely fashion. This situation becomes more complex as each of the companies managing the grid operates within a unique set of local business and regulatory parameters.

In cases of power grid failure there exists a small window of time in which decisions can be made that will minimize the impending failure's impact, but a lack of real-time monitoring or excessive latency in the flow of data from the collection point to a central processing unit can eliminate that opportunity. Instead of data being processed collectively and quickly, in a fashion similar to how space launches are managed at Houston command center, grid operators often resort to the telephone when a crisis hits.



The Unified Smart Grid has recently been proposed as a way to create a more reliable, secure, efficient, safe, economic and environmentally friendly generation, transmission and consumption infrastructure.

Smart Grid Principal Characteristics^[1]

- Enable active participation by consumers
- Accommodate all generation and storage options
- Enable new products services and markets
- Provide power quality for the digital economy
- Optimize asset utilization and operate efficiently
- Anticipate and respond to system disturbances
- Operate resiliently against attack and natural disaster

Smart Grid Milestones^[1]

Smart grid milestones represent the building blocks of the smart grid. Completion of each requires the deployment and integration of various technologies and applications. The sequence for implementing these milestones will depend on the specific circumstances of those involved.

Consumer Enablement (CE) empowers consumers by giving them the information and education they need to effectively utilize the new options provided by the smart grid. CE includes solutions such as Advanced Metering Infrastructure (AMI), home area networks with in-home displays, distributed energy resources (DER), and demand response programs as well as upgrades to utility information technology architecture and applications that will support “plug-and-play” integration with all future smart grid technologies.

Advanced Distribution Operations (ADO) improves reliability and enables “self-healing.” ADO includes solutions such as smart sensors and control devices, advanced outage management, distribution management and distribution automation systems, geographical information and other technologies to support 2-way power flow and micro-grid operation.

Advanced Transmission Operations (ATO) integrates the distribution system with Regional Transmission Organization operational and market applications to enable improved overall grid operations and reduced transmission congestion. ATO includes substation automation, integrated wide area measurement applications, power electronics, advanced system monitoring and protection schemes and modeling, simulation, and visualization tools to increase situational awareness and provide a better understanding of real time and future operating risks.

Advanced Asset Management (AAM) integrates the grid intelligence acquired in achieving the other milestones with new and existing asset management applications. This integration enables utilities to reduce Operations and Maintenance and capital costs and better utilize assets during day-to-day operations. Additionally, it significantly improves the performance of capacity planning, maintenance, engineering and facility design, customer service processes, and work and resource management.

TRENTON Systems, Inc.
2350 Centennial Drive • Gainesville, Georgia 30504
Sales 800.875.6031 • Phone 770.287.3100 • Fax 770.287.3150

Embedded computers are ideal platforms for addressing four key principals of smart grid technology:

- Control
- Sensing
- Measurement
- Communications

Deployed at points across the grid, from power generation to transmission and end user consumption, embedded systems save energy and reduce operating costs while increasing reliability and redundancy. By monitoring and reporting vital health and usage statistics, system engineers can better manage power loads and distribution, as well as energy storage facilities designed to deal with varying supply levels coming from sources such as wind turbines and solar arrays during a typical 24-hour period.

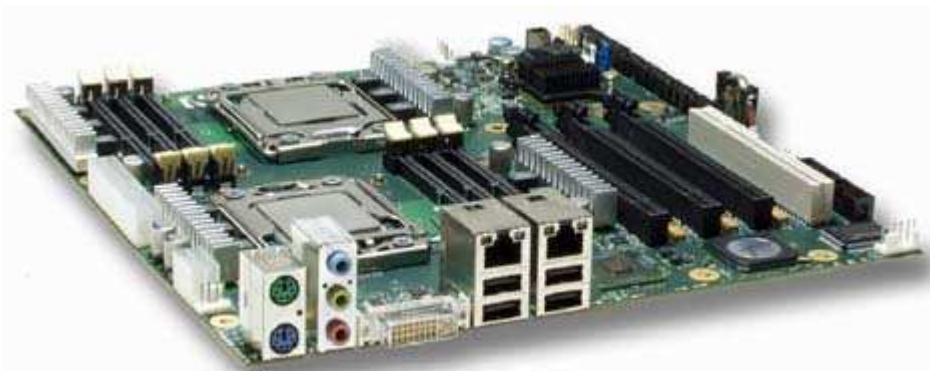

Trenton's [TRC4007 rackmount computer](#), utilizing the [JXM7031 uATX embedded motherboard](#), is a fully integrated computing platform designed for smart grid applications. Supported by a five-year factory warranty, the JXM7031 is built with embedded Intel processors and other extended life components to ensure industrial computer stability and availability for critical deployments exceeding seven years.



Looking at the layout diagram for Trenton JXM7031 motherboard, the first thing you notice are the two, quad-core processors. While plenty of motherboards are available with dual-CPU's, the JXM7031 is the first motherboard in the world to support dual, quad-core processors and PCI Express 2.0 option card slots all in a compact MicroATX form factor measuring 9.6" (24.4cm) x 9.6" (24.4cm).

JXM7031 - Layout Diagram

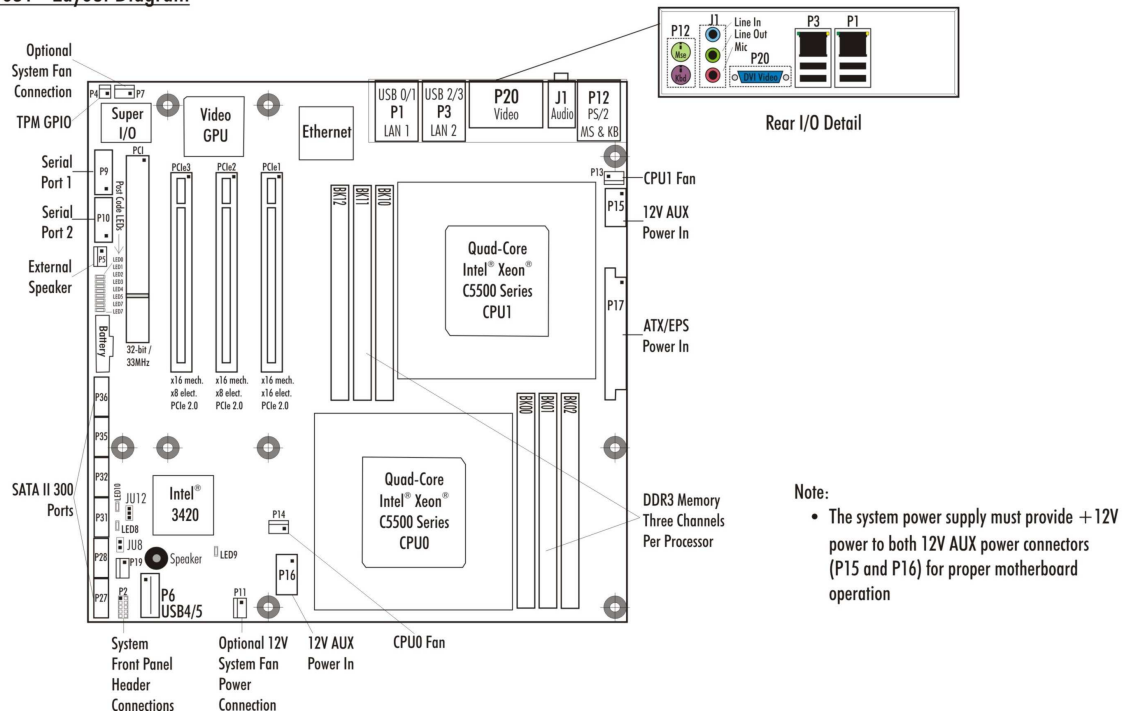

The Intel Xeon C5500 series processors feature power-efficient CPU core designs, direct DDR3-1333 system memory interface and direct PCI Express 2.0 interface links. The combination of these three important processor attributes saves power and delivers remarkable system performance increases which benefit a range of smart grid embedded computing applications such as those listed below.

Smart Grid Embedded Computing Applications

- Intelligent Substations
- Advanced Metering Systems
- Grid Modeling & Simulation
- Distribution Automation
- Demand / Response Analysis
- Wind Turbine Control
- Cyber Security Detection
- Power Load Management
- Fault Detection Devices
- Power Quality Monitoring
- Solar Array Tracking

TRENTON Systems, Inc.
 2350 Centennial Drive • Gainesville, Georgia 30504
 Sales 800.875.6031 • Phone 770.287.3100 • Fax 770.287.3150

The three card slots on the JXT7031 embedded motherboard are configured to support an array of option cards. For example, a x16 PCIe mechanical slot driven with a x16 PCIe 2.0 electrical link can support high-end video cards or ultra-fast A/D data acquisition cards utilizing onboard FPGAs.

JXM7031 - Block Diagram

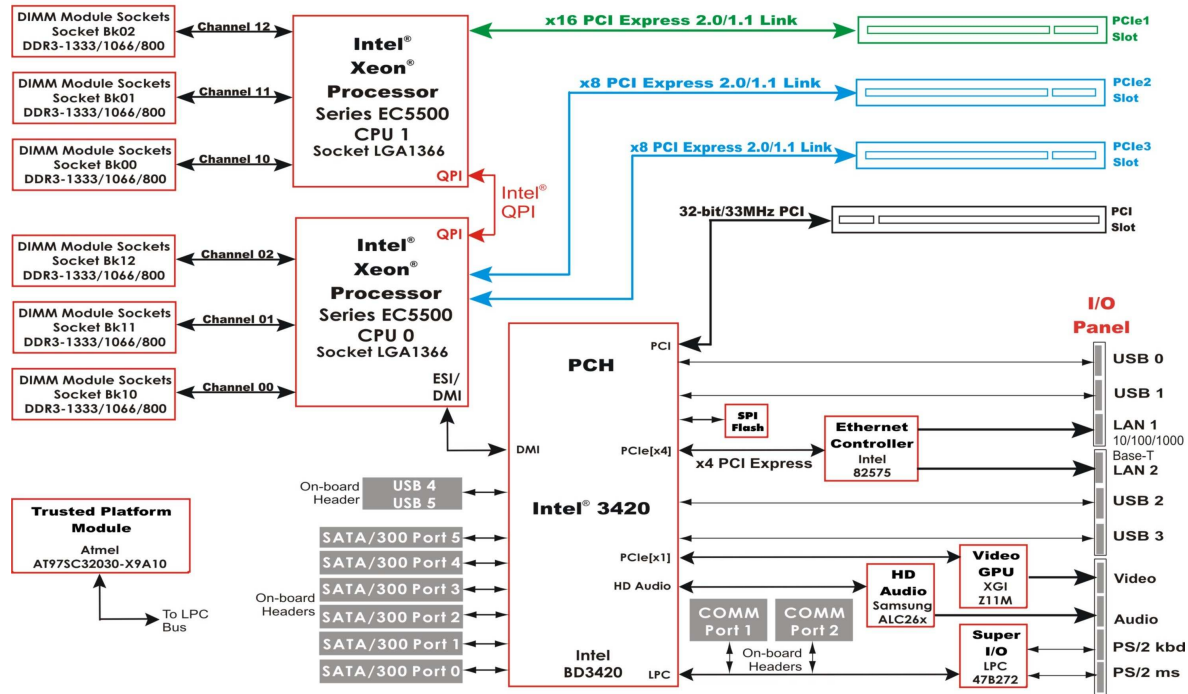

The TRC4007's integrated 8.4" LCD Display allows for constant monitoring of incoming sensor data and the using the built-in keyboard and mouse tray an onsite operator can make adjustments to operating equipment. The three front-mounted hot-swap hard disk drives can be setup in a RAID configuration for enhanced data security and reduced mean-time-to-repair (MTTR).

So what's the net effect of creating a smarter grid? According to the US Department of Energy we can save between 46 and 117 billion dollars over the next 20 years, and that's in addition to reducing air pollution and our dependence on imported oil – definitely a smart way to go.

Copyright 2010 by TRENTON Systems Inc. All rights reserved.

Trenton Systems, Inc.
 2350 Centennial Drive
 Gainesville, Georgia 30504
 Sales: 800.875.6031 in the U.S. or 770.287.3100 outside the U.S. Fax: 770.287.3150
 E-mail: Sales@TrentonTechnology.com Web: www.TrentonTechnology.com

Reference 1: National Energy Technology Laboratory (NETL)