



Installation & Maintenance Manual

ISO 9001:2015



6D-0885



SAI GLOBAL

ISO 9001
Quality



For additional information call

800-206-4013

610-363-8903

Fax: 610-524-9242

email: dft@dft-valves.com

www.dft-valves.com

P.O. Box 566
Exton, PA 19341-0566

04/27/20- R7

1

DFT®

DFT® specializes in spring assisted **In-Line** Check Valves that prevent **Water Hammer** and reverse flow and insure long life if **properly sized** for the flow not the line size. DFT customizes the internal components for optimal performance without changing the line size.

DFT In-Line check valves do not rely on gravity or reverse fluid flow to close. Instead as the forward velocity of the fluid slows, the spring-assist starts to close the disc.

Due to the spring assist and short travel distance of the disc, by the time forward velocity has decreased to zero, the valve disc has reached the seat and the valve is closed.

With reverse flow eliminated, the forces necessary to produce water hammer on both the upstream and downstream sides of the valve are substantially eliminated.

DFT’s objective is to solve and prevent check valve problems and failures in critical service applications. All valves are manufactured at our facility in Exton, PA.

DFT is considered the control valve of check valves, the “Check Valve Doctor”.

Our check valve sizing program insures you will know in advance what to expect from the check valve as opposed to after start up.

DFT In-Line check valves are used in all industries. They include chemical, food & beverage, mining, oil & gas, power, pulp & paper, refining and steel.

DFT In-Line check valves should provide trouble free service. Occasionally problems do arise or inspection is required. This manual provides information for inspection and repairs of your DFT check valves should the need arise. No special tools are needed.

Check Valve Assistance

Contact DFT at **800-206-4013** for assistance, questions or the Authorized DFT repair facility in your area.

DFT is available to review your check valve sizing requirements and assist in selecting the proper check valve.

Table of Contents

<u>ITEM</u>	<u>PAGE</u>	<u>ITEM</u>	<u>PAGE</u>
ALC®	6 - 7	PDC®	16 - 17
Basic-Check®	8 -9	Repair Kits/Spare Parts.....	4
DLC®	10	Restrictor Check.....	8 - 9
DSV®	11	SCV®	18 - 19
Excalibur®	12 - 13	SCV-R®	20 - 21
Full Face Seat Illustration	Back Cover	Split Face Seat Illustration..	27
GLC®	14 - 15	TLW®	22-24
Installation Information....	3	Trouble Shooting Guide.....	3
Materials of Construction.	5	Vacuum Breaker.....	8 - 9
		WLC®	25-26

ALC, Basic-Check, DLC, DSV, Excalibur, GLC, PDC, SCV, SCV-R, TLW, and WLC are registered trademarks of DFT® Inc.

INSTALLATION PROCEDURES

All DFT® In-Line check valves can be installed in the line in any orientation. The operation of the DFT check valve is not affected by the position of the valve itself. **The only requirement is that the flow arrow on the body casting must be pointed in the direction of the flow.** If the DFT check valve is to be installed in an orientation with flow downward, that should be specified when ordering. A stronger spring may be required to compensate for the weight of the disc and any static head.

DFT® is the recommended check valve for use with any expansion joint due to internals remaining within the valve body/envelope. All other wafer style designs should be avoided due to internal flapper interference with adjoining equipment.

The operation of DFT In-Line check valves is not affected by its proximity to elbows, tees, control valves etc. However, installing DFT In-Line check valves directly to the outlet of such devices may result in decreased life due to the turbulence caused by the fitting. DFT recommends that all DFT In-Line check valves be installed a minimum of five pipe diameters downstream of any fitting that could cause turbulence.

Flange gaskets: The ALC® (10"-24"), DLC®, Excalibur® and new "Full Face" GLC® and PDC® can use both non-metallic and spiral wound gaskets for "all" ASME Classes. Non-metallic gaskets are recommended for ASME Class 150 and 300 WLC®'s and older "Split Face" GLC's and PDC's. Spiral wound gaskets can be used for all ASME Class 600 and higher valves. An illustration of end flange gaskets is shown on page 27.

Check Valve Trouble Shooting Guide

Symptom	Cause	Solutions
Water hammer, loud noise, vibration, ruptured piping, equipment damage	Slow closing check valve	In-Line spring assisted check valve.
Stem wear (pointed stem), elongated seat guide, bushing wear	Low flow, pulsating flow, improper sizing	Custom sizing of the check valve internals. PDC for reciprocating air or gas mediums.
Excessive seat leakage (Greater than MSS-SP61)	Dirt, trash, foreign substance in the valve	Clean out the valve. Install strainers if it is a reoccurring problem. Install a soft seat if bubble tight shutoff is required.
Noise, clicking, tapping	Low flow, pulsating flow, improper sizing	Custom sizing of the check valve internals. PDC for reciprocating air or gas mediums.
Reverse flow	Slow closing check valve	In-Line spring assisted check valve.
Component breakage, valve failure	Reciprocating compressor	PDC for reciprocating air or gas mediums.
Missing internals	Valve not full open, pulsing flow, improper sizing	Custom sizing of the check valve internals. PDC for reciprocating air or gas mediums.

REPAIR KITS/SPARE PARTS

Repair Kits are available for all but the DLC® and Cast Iron check valves. If you have any questions regarding the repair kit for your DFT® check valve contact DFT at 800-206-4013, 610-363-8903 or dft@dft-valves.com

Additional comments:

1. **Serial Numbers** – ALC® Excalibur®, GLC®, PDC® , DLC®, and WLC®'s.

Providing the valve Serial Number will insure receipt of the proper repair kit for your valve.

- All Excalibur's, GLC's, DLC's, WLC's, and PDC's contain Serial Numbers. They are located on the valve nameplate.
- Basic-Check® style valves, Cast Iron GLC's, and SCV®'s do not contain serial numbers.

2. Soft seats are available with "Repair Kits". Contact DFT.

WARNING:

If the system fluid is hazardous, take appropriate precautions before performing maintenance or repair. Make sure to bleed off pressure from the line before removing the valve. Once removed from the line, flush and cycle the valve to remove any remnants of the media that could occupy cavities or pockets within the valve such as between the body and seat or bushing and body.

Danger - Caution: DFT Valves are not considered a "dead-end" service valve. The upstream (seat) end of the valve should never be disconnected from the line if line pressure has not been completely relieved from the downstream end of the valve. The "seat" end of the valve must always remain bolted to the mating flange when the valve is exposed to downstream pressure to avoid possible blow-out of the internals. The retaining screws are not designed to hold the seat in place when the valve is exposed to downstream pressure.

STANDARD MATERIALS OF CONSTRUCTION

COMPONENT	DFT® PRODUCT	CARBON STEEL BODY	STAINLESS STEEL BODY
Body ⁽¹⁾	ALC®, Excalibur®, GLC®, PDC®, WLC®	A216 WCB	A351 CF8M
	DLC®, SCV®, SCV-R®	N/A	A351 CF8M
Disc/stem assembly	ALC	316 SS/ Nitronic 60	316 SS/ Nitronic 60
	BSS®, DLC, SCV, SCV-R	N/A	A240 316 SS disc
	Excalibur, GLC, WLC	A351 CF8M/A479 316	A351 CF8M/A479 316
	PDC	A351 CF8M disc	A351 CF8M disc
	WLC 1" & 1-1/2" CI 900+	17-7 disc	17-7 disc
Disc guide	PDC	A479 316 SS	A479 316 SS
Seat	ALC	316 SS	316 SS
	BSS	N/A	A582 303 SS
	DLC, SCV, SCV-R	N/A	A351 CF8M
	Excalibur, GLC, PDC, WLC	A351 CF8M	A351 CF8M
Spring	Excalibur, GLC, PDC, WLC	A313 316	A313 316
	ALC	Inconel® X-750	Inconel® X-750
	DLC, SCV, SCV-R	N/A	Inconel® X-750
Ball check spring	PDC	Inconel® X-750	Inconel® X-750
Bushing	ALC, Excalibur, GLC, WLC	A479 316 SS	A479 316 SS
	PDC	Rulon®	Rulon®
Bolting	Excalibur	A193-B7 (Stud) & A194-2H (Nut)	
Gasketing	ALC, Excalibur, GLC	CFG ⁽²⁾	CFG ⁽²⁾
	Excalibur ASME Class 600+	316 Spiral wound with Flexible Graphite Filler	
Body Seal	SCV, SCV-R	N/A	Zelon
Ball check	PDC	440C SS	440C SS
Guide ring	PDC	Teflon	Teflon
Orifice plug	PDC	A479 316 SS	A479 316 SS
Seal ring	PDC	Teflon®/Hastelloy® C276	Teflon®/Hastelloy® C276
Spring retainer – ball check	PDC	A479 316 SS	A479 316 SS
Guard	BSS ¼", 3/8" & ½"	N/A	303SS
	BSS ¾" to 2-1/2"	N/A	A351 CF8M
Retaining ring	BSS	N/A	A313 316SS
Seat retainer assembly	SCV-R	N/A	316SS

Notes:

1. Other Body materials available – Alloy 20, Hastelloy C, Monel®, Titanium, etc.
2. 316/Graphite material.

ALC® MAINTENANCE PROCEDURES

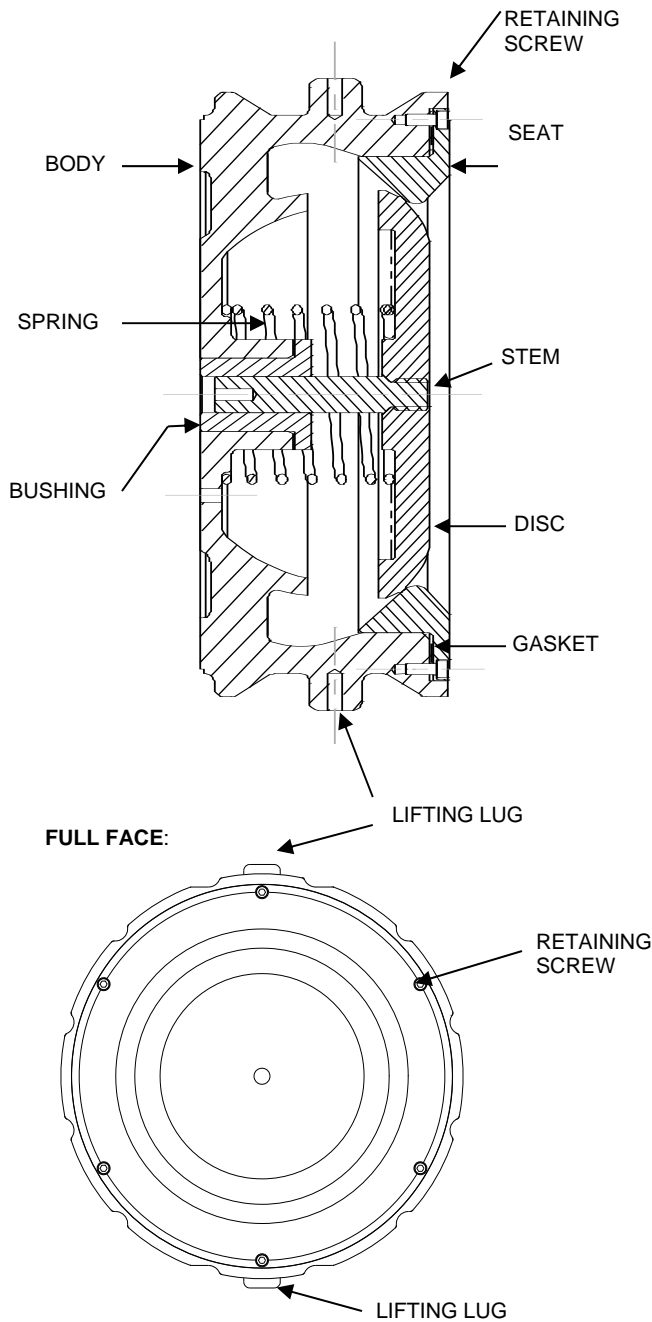

SPLIT FACE: See page 27 for diagram reference.

DIS-ASSEMBLY:

- 1) Remove the seat from the valve.

CAUTION: The disc is spring loaded against the seat.

 - A) Remove the retaining screws with a hex wrench while holding the disc back.
 - B) Pull the seat from the body.
 - C) Remove the disc/stem assembly and spring.
 - D) Press out bushing (interference fit).

2) Inspection:

Inspect the seating surfaces, bushing and stem for wear. The seat and disc may be lapped with a suitable fine grade lapping compound. Remove any scale build up on the stem and bushing.

Replace the trim if total stem-to-bushing clearance exceeds 1/16".

SOFT SEATING: For valves with an o-ring soft seat, inspect the o-ring and replace if cracked or excessively deformed.

3) Refacing:

A) METAL TO METAL SEATING: A total of .03" metal per surface has been provided on the seat and disc to permit refacing when necessary. It is important that the facing remain perpendicular to the axis of the parts. The finish should be 32 Ra or better.

B) SOFT SEATING: The seat may be refaced as outlined above. The disc **CAN NOT** be refaced; if the o-ring groove is damaged, replace the trim. It is acceptable for the contact surface of the disc to have small scratches and/or pits, provided the groove is undamaged.

4) Soft Seat Replacement:

A) To replace the ring, pry it out of the groove using a thin piece of metal (a

- .005" thick feeler gage works well) taking care not to scratch the inside wall of the o-ring groove.
- B)** Clean out the groove. Lubricate a new o-ring with water soluble lubricant such as dishwashing detergent or suitable lubricant compatible with the process fluid.
 - C)** To install the new o-ring, push one section of the o-ring into the groove with your thumb or a soft roller, then push the section 180° opposite from the first into the groove. Continue by pushing in the o-ring at points 90° to the original sections. Finally, push the rest of the
 - D)** Rub the o-ring in a circular motion in the groove with your thumb to even-out any bumps.

- A)** Press bushing into body.
 - B)** Place spring into the body.
 - C)** Insert the disc/stem assembly
 - D)** Install the body gasket.
 - E)** Lower the seat into the body and install the retaining screws with a hex wrench.
- 2)** Stroke the disc to work the valve a couple of times to check for free disc movement.
 - 3)** Re-install the valve in the line with the flow arrow on the body pointing in the direction of flow.

RE-ASSEMBLY:

1) Seat Installation

VALVE SIZE	10"	12"	14"	16"	18"	20"	24"
Retaining screws	¼-20	5/16-18	5/16-18	5/16-18	3/8-16	3/8-16	3/8-16
Lifting lug	½-13 thread	½-13 thread	½-13 thread	½-13 thread	½-13 thread	½-13 thread	½-13 thread

All dimensions in inches.

BASIC-CHECK® /RESTRICTOR CHECK/ VACUUM BREAKER /FBC MAINTENANCE PROCEDURES

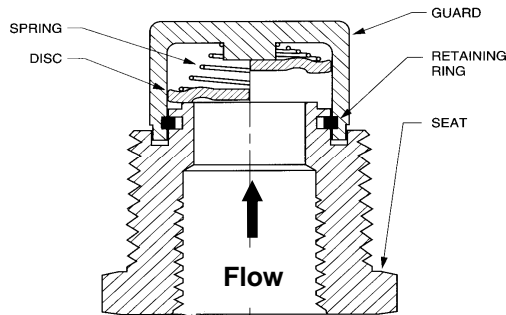

Basic-Check

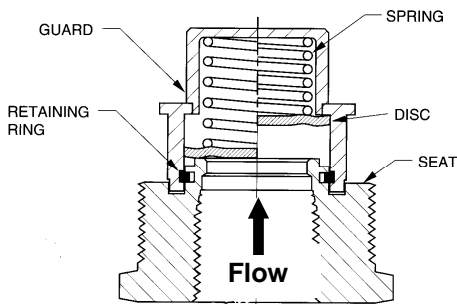

Restrictor Check

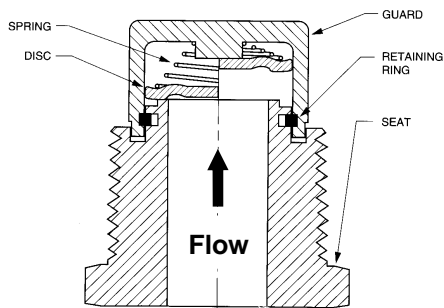

Vacuum Breaker

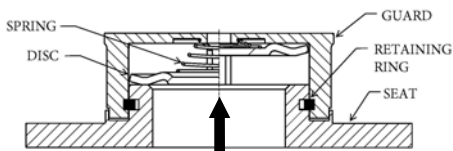

Flow

FBC

CAUTION: The **Restrictor Check** spring is under higher compression than the Basic-Check and Vacuum Breaker units. Use caution when the units are disassembled.

DIS-ASSEMBLY:

- 1) Draw together the ends of the retaining ring with pliers.
- 2) Lift the guard off the seat.
- 3) Seating surfaces may be cleaned using a soft cloth and appropriate solvent. Avoid scratching the seating surface.

4) Inspection:

Check for scratches on the seating surfaces. If they can be felt with your fingernail, recondition or replace the disc and/or seat. Check the disc and guide ribs for signs of wear. If the total disc/rib clearance exceeds 1/16", replace the valve.

SOFT SEATING: For valves with an o-ring soft seat, inspect the o-ring and replace if cracked or excessively deformed.

5) Soft Seat Replacement:

- A) To replace the o-ring, pry it out of the groove using a thin piece of metal (a .005" thick feeler gage works well) taking care not to scratch the bottom of the o-ring groove.
- B) Clean out the groove.
- C) Lubricate a new o-ring with water soluble lubricant such as dishwashing detergent.
- D) To install the new o-ring, push one section of the o-ring into the groove with thumb or a soft roller, then push the section 180° opposite from the first into the groove. Continue by pushing in the o-ring at points 90° to the original sections. Finally push the rest of the ring into the groove.
- E) Rub the o-ring in a circular motion in the groove with your thumb to even-out any bumps.

RE-ASSEMBLY:

- 1) Place retaining ring in groove of seat.
- 2) Place spring, small end first, onto guard spring hub.
- 3) Position the disc over the spring and between the four guard legs. Be sure the valve disc is replaced with the side marked "spring side" against the spring.
- 4) While holding the disc and spring in the guard with one hand, compress the retaining ring with suitable pliers into the seat groove with the other, then position the disc/spring/guard over the seat with the notches in the guard legs aligned with the retaining ring and release the retaining ring, locking the guard onto the seat.
- 5) Lift the disc to work the valve a couple of times to check for free disc movement.
- 6) Re-install the valve.

Caution:

Do not allow pipe thread sealants or tape to be forced into the valve operating area or to become lodged on the valve seating surface. Protect the valves from excessive heat from welding or brazing which may distort the seat bushing or damage the spring.

DLC[®] MAINTENANCE PROCEDURES

The DLC In-Line check valve has no user serviceable components inside. In operation, the valves are designed to be fully automatic. On start-up, the flow forces the disc open. Continuing flow holds the disc in an open position. Upon shut down, the spring returns the disc to the seat prior to flow reversal, preventing backflow.

WARNING: If the system fluid is hazardous, take appropriate precautions. Make sure to bleed off pressure from the line before removing the valve.

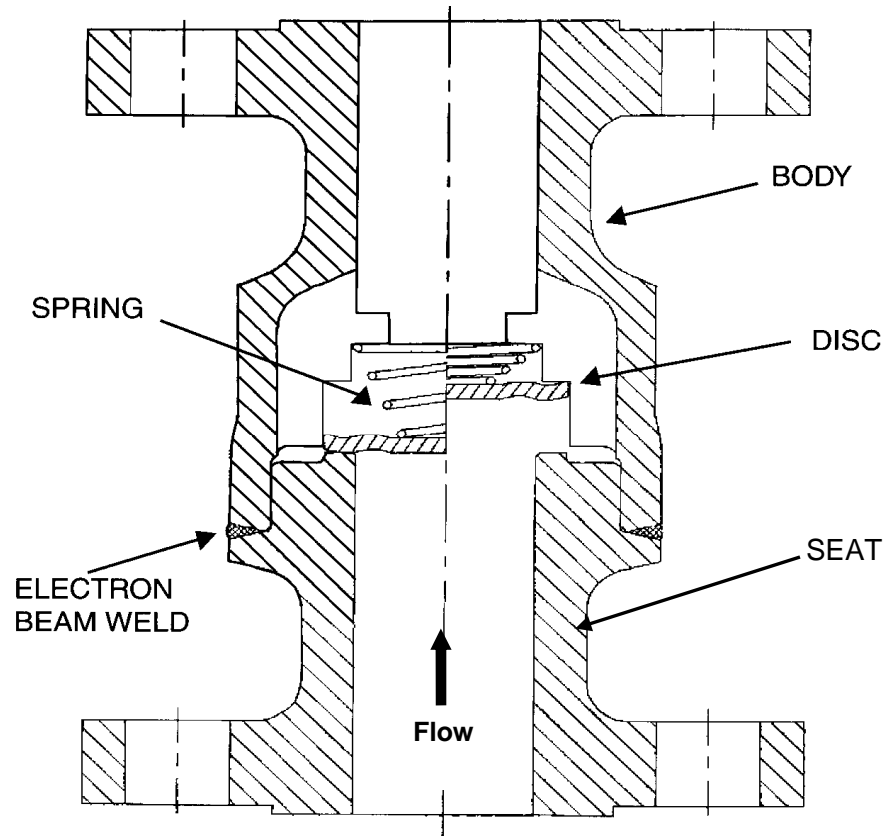

DSV[®] MAINTENANCE PROCEDURES



58-01

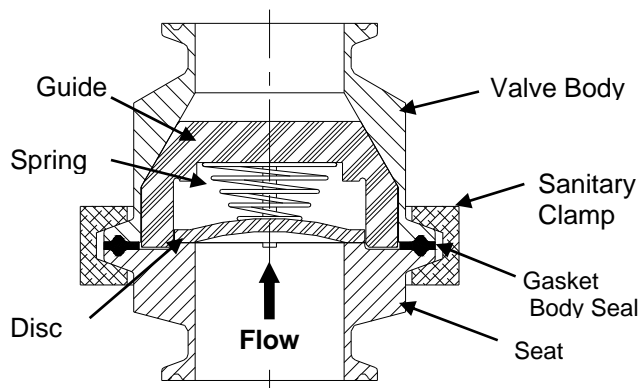

Vertical Valve

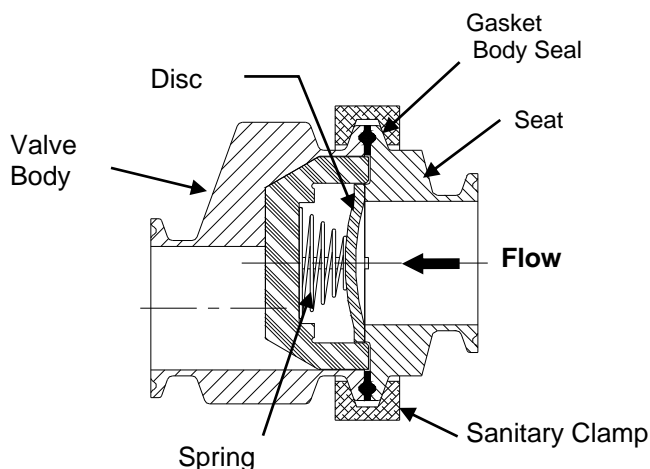

Horizontal Valve

STANDARD MATERIALS OF CONSTRUCTION

Body	316L SS (A351 CF3M)
Seat	316L SS (A351 CF3M)
Disc	316 SS
Spring	316 SS (electropolished)
Guide Assembly	316 SS
Body Seal	EPDM (-75°F to +300°F)
Clamp	304 SS
Internal Surface Finish	32 Ra

DIS-ASSEMBLY:

- 1) To access valve internals, loosen the wing nut of the sanitary clamp and remove the clamp from the center of the valve.
- 2) Carefully pull apart the valve body and seat. Note that once the seat has been removed from the valve body, the disc and spring are loose pieces.
- 3) Remove the gasket body seal from the valve body (or seat) and inspect it carefully for signs of damage or wear. The disc, spring, and disc guide assembly may be removed from the valve body for inspection and cleaning.
- 4) Seating surfaces may be cleaned using a soft cloth and appropriate solvent. Avoid scratching the seating surface.

RE-ASSEMBLY:

- 1) Place disc guide assembly in valve body. Orientation of the guide assembly legs is not critical. Place spring, large end first, onto guard spring hub.
- 2) Position the disc over the spring and between the four legs of the guide assembly. Be sure the valve disc is replaced with the "seat side" (marked on disc) against the valve seat.
- 3) Place the gasket body seal into the groove in the valve body. Place the valve seat onto the valve body ensuring that the valve seat is centered up on the disc and that the gasket body seal engages in the groove of both the valve body and the seat.
- 4) Reaching through the end of the valve seat, depress the disc a couple of times to check for free disc movement. Wrap the clamp around the valve making sure the valve body and seat are fully captured. Tighten the wing nut of the clamp to approximately 20 ft-lbs.
- 5) Re-install the valve in the line with the flow arrow on the body pointing in the direction of flow.

EXCALIBUR® MAINTENANCE PROCEDURES

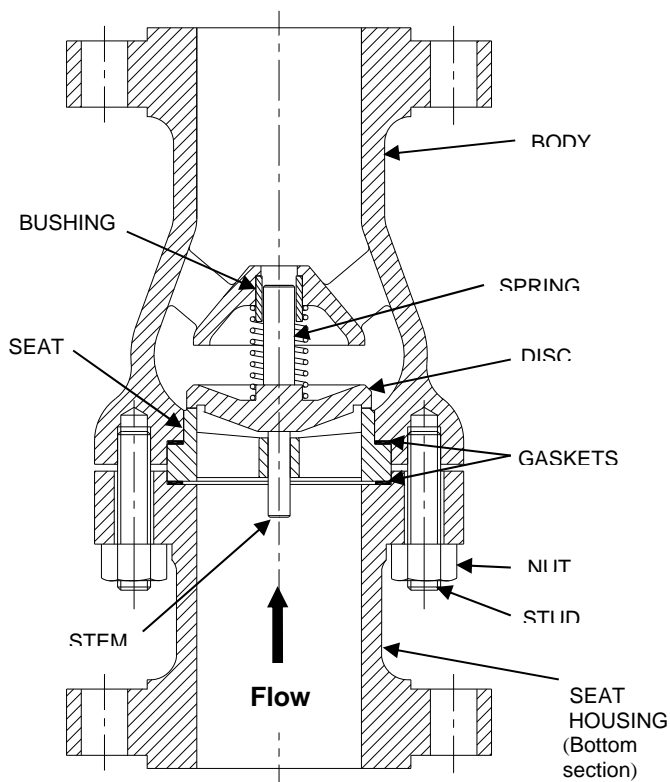

DIS-ASSEMBLY:

- 1) Position the valve with the arrow on the side facing downward on the floor or bench.
- 2) Unscrew the nuts holding the two parts of the body together and lift the top section of the body from the bottom section.
- 3) Lift the seat ring from the bottom section of the body being careful not to damage the seating surface. Lift the disc/stem assembly from the body and remove the spring.
- 4) **Inspection:**
Inspect the seating surfaces, bushing and seat guide for wear. The seat and disc may be lapped with a suitable fine grade lapping compound. Remove any scale build up on the stem and guides. Replace the trim if total stem-to-bushing or seat guide clearance exceeds 1/16".

SOFT SEATING: For valves with an o-ring soft seat, inspect the o-ring and replace if cracked or excessively deformed.

5) Refacing:

A) METAL TO METAL SEATING A total of .03" metal per surface has been provided on the seat and disc to permit refacing when necessary. It is important that the facing remain perpendicular to the axis of the parts. The finish should be 32 Ra or better.

B) SOFT SEATING: The disc may be refaced as outlined above. The seat CANNOT be refaced; if the o-ring groove is damaged, replace the trim. It is acceptable for the contact surface of the seat to have small scratches and/or pits, provided the groove is undamaged.

- 6) Remove the old gasket material and clean gasket surfaces on both sides of the seat ring and on both body sections.

7) Soft Seat Replacement:

- A) To replace the o-ring, pry it out of the groove using a thin piece of metal (a .005" thick feeler gage works well) taking care not to scratch the bottom of the o-ring groove.
- B) Clean out the groove.
- C) Lubricate a new o-ring with water soluble lubricant such as dishwashing detergent or suitable lubricant compatible with the process fluid.
- D) To install the new o-ring, push one section of the o-ring into the groove with your thumb or a soft roller, then push the section 180° opposite from the first into the groove. Continue by pushing in the o-ring at points 90° to the original sections. Finally, push the rest of the ring into the groove.
- E) Rub the o-ring in a circular motion in the groove with your thumb to even-out any bumps.

RE-ASSEMBLY:

- 1) Insert the spring into the spring retainer in the bottom body section.
- 2) Insert the disc/stem assembly into the disc guide of the bottom body section insuring that the seating surface faces upward.
- 3) Place a new gasket on the bottom body section.
- 4) Place the seat ring (seating surface downward) on the gasket.
- 5) Place a new gasket on top of the seat ring.

- 6) Place the top body section onto the bottom body section.
- 7) Add thread lubricant to exposed threads. Hand tighten nuts. With wrench, tighten nuts (as shown in Figure 1) gradually in three or four steps to the torque shown in Table 1. After 24 hours tighten nuts again to the listed torque.
- 8) Lift the disc to work the valve a couple of times to check for free disc movement.
- 9) Re-install the valve in the line with the flow arrow on the body pointing in the direction of flow. (To insure correct operation of the gaskets, the body bolts should be re-torqued after start-up.)

TABLE 1: TORQUE VALUE RANGES

<u>Bolt/Thd Size</u>	<u>Initial Torque (Ft. lbs.)</u>	<u>Bolt/Thd Size</u>	<u>Initial Torque (Ft. lbs.)</u>
3/8"	15	1-1/4"	500
7/16"	20	1-3/8"	770
1/2"	35	1-1/2"	950
9/16"	50	1-5/8"	1300
5/8"	60	1-3/4"	1640
3/4"	110	1-7/8"	2060
7/8"	170	2"	2550
1"	260	2-1/8"	3100
1-1/8"	390	2-1/4"	3740

NOTE: Torque values are based on new fasteners.

FIGURE 1: BOLT TORQUING SEQUENCE

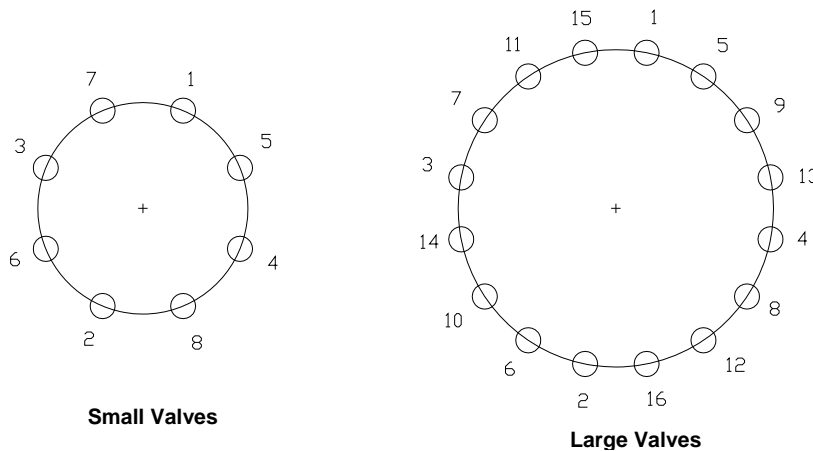

GLC[®] MAINTENANCE PROCEDURES

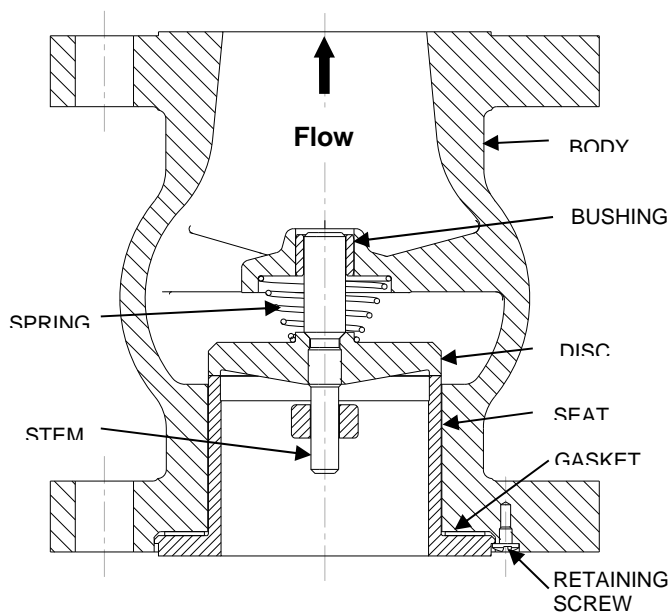

Caution: The GLC is not considered a “dead-end” service valve. The upstream (seat) end of the valve should never be disconnected from the line if line pressure has not been completely relieved from the downstream end of the valve. The “seat” end of the valve must always remain bolted to the mating flange when the valve is exposed to downstream pressure to avoid possible blow-out of the internals. The retaining screws are not designed to hold the seat in place when the valve is exposed to downstream pressure.

DIS-ASSEMBLY:

1) Remove the seat from the GLC.
There are two (2) different seat designs for the GLC:

A) DROP-IN SEAT:

- i) Remove the retaining screws.
- ii) Pull the seat from the body.
- iii) Remove the disc and spring.
- iv) Remove the o-ring or gasket if the valve contains a “Full Face” seat design.
- v) Press out guide bushing (interference fit).

B) PUNCH-PRICKED SEAT

(1” & 1 ½” only):

- i) From the outlet end, drive the stem with a soft metal or plastic bar/rod. This will push the disc/stem and seat out the inlet end.
- ii) Remove the spring, bushing, (and body seal o-ring on some units).

2) Inspection:

Inspect the seating surfaces, bushing and seat guide for wear. The seat and disc may be lapped with a suitable fine grade lapping compound. Remove any scale build up on the stem and guides. Replace the trim if total stem-to-bushing or seat guide clearance exceeds 1/16”.

SOFT SEATING: For valves with an o-ring soft seat, inspect the o-ring and replace if cracked or excessively deformed.

3) Refacing:**A) METAL TO METAL SEATING:**

A total of .03" metal per surface has been provided on the seat and disc to permit refacing when necessary. It is important that the facing remain perpendicular to the axis of the parts. The finish should be 32 Ra or better.

B) SOFT SEATING:

The disc may be refaced as outlined above. The seat CANNOT be refaced; if the o-ring groove is damaged, replace the trim. It is acceptable for the contact surface of the seat to have small scratches and/or pits, provided the groove is undamaged.

4) Soft Seat Replacement:

- A)** To replace the o-ring, pry it out of the groove using a thin piece of metal (a .005" thick feeler gage works well) taking care not to scratch the bottom of the o-ring groove.
- B)** Clean out the groove.
- C)** Lubricate a new o-ring with water soluble lubricant such as dishwashing detergent or suitable lubricant compatible with the process fluid.
- D)** To install the new o-ring, push one section of the o-ring into the groove with your thumb or a soft roller, then push the section 180° opposite from the first into the groove. Continue by pushing in the o-ring at points 90° to the original sections. Finally, push the rest of the ring into the groove.
- E)** Rub the o-ring in a circular motion in the groove with your thumb to even-out any bumps.

RE-ASSEMBLY:**1) Seat Installation**

Install the seat into the valve body.

NOTE: There are two (2) different seat designs:

A) DROP-IN SEAT:

- i) Press bushing into body.
- ii) Place spring, (large end first for conical springs) into the body.
- iii) Insert the disc/stem assembly.
- iv) Install the body o-ring or gasket if the valve contains a "Full Face" seat.
- v) Lower the seat into the body and install the retaining screws.

B) PUNCH-PRICKED SEAT:

- i) Press bushing into body.
- ii) Place spring, (large end first for conical springs) into the body.
- iii) Insert the disc/stem assembly.
- iv) Install the body o-ring (If required).
- v) Press in seat until bottomed. (If seat is not tight, remove and re-stake the O.D. of the seat with a sharp point punch at 3 or 4 places to create interference points, then press seat back into body.)

- 2)** Stroke the disc to work the valve a couple of times to check for free disc movement.

- 3)** Re-install the valve in the line with the flow arrow on the body pointing in the direction of flow.

PDC® MAINTENANCE PROCEDURES

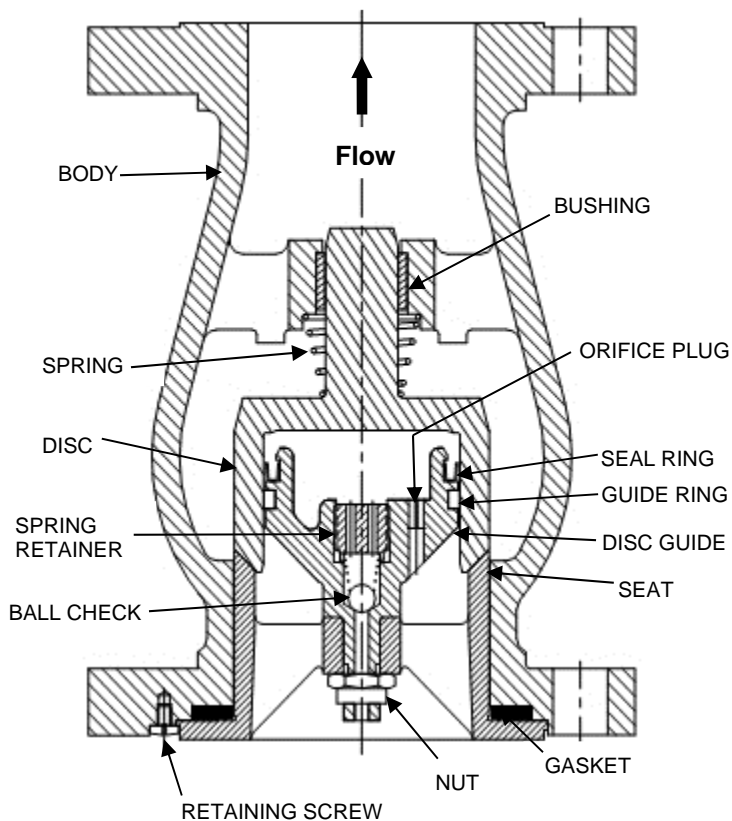

US Patent # 4,766,929 #4,693,270

Caution: The PDC is not considered a “dead-end” service valve. The upstream (seat) end of the valve should never be disconnected from the line if line pressure has not been completely relieved from the downstream end of the valve. The “seat” end of the valve must always remain bolted to the mating flange when the valve is exposed to downstream pressure to avoid possible blow-out of the internals. The retaining screws are not designed to hold the seat in place when the valve is exposed to downstream pressure and disconnected from the pipe.

DIS-ASSEMBLY:

1) Remove the seat from the PDC.

A) DROP-IN SEAT:

- i) Remove the retaining screws.
- ii) Push out the disc, disc guide and seat as an assembly.
- iii) Remove the gasket if the valve contains a “Full Face” seat design.

2) Slide the Disc off the Disc Guide.

3) Remove guide ring and seal ring. Take care not to scratch the groove surfaces. It may be necessary to destroy the seal ring to remove.

4) Remove the **spring retainer**:

A) **2” through 8”:**

The retainer is threaded-in, then the threads are staked to lock them in.

- i) Grind away the damaged threads where they are staked.
- ii) Stick two (2) 1/8” rods (or drill bits) in the two (2) holes.
- iii) With a large screwdriver wedged between the rods, unscrew the retainer.

B) **10” and larger**

The retainer is dropped-in, then the edge of the bore is staked to lock it in.

- i) Grind away the upset metal.
- ii) Push the check disc and retainer out.

5) Clean the Disc, Disc Guide and check ball (or the check disc on 10” and larger valves) with a suitable solvent.

6) Inspection:

- A) Inspect the bore of the disc; replace if scored.
- B) Inspect the Orifice in the Disc Guide; clean out if dirty or clogged.
- C) Inspect the Bushing in the Body for excessive wear; if I.D. of Bushing is visibly out-of-round due to wear on one side or if stem-to-bushing or seat guide clearance exceeds 1/16” remove it by pressing it out.
- D) Remove any scale build-up on stem and disc bore.

SOFT SEATING: For valves with an o-ring soft seat, inspect the o-ring and replace if cracked or excessively deformed.

7) Refacing:

A) METAL TO METAL SEATING:

A total of .03" metal per surface has been provided on the seat and disc to permit refacing when necessary. It is important that the facing remain concentric to the axis of the parts. The finish should be 32 Ra or better.

B) SOFT SEATING:

The disc may be refaced as outlined above. The seat CANNOT be refaced; if the o-ring groove is damaged, replace the trim. It is acceptable for the contact surface of the seat to have small scratches and/or pits, provided the groove is undamaged.

8) Soft Seat Replacement:

A) To replace the o-ring, pry it out of the groove using a thin piece of metal (a .005" thick feeler gage works well) taking care not to scratch the bottom of the o-ring groove.

B) Clean out the groove.

C) Lubricate a new o-ring with water soluble lubricant such as dishwashing detergent or suitable lubricant compatible with the process fluid.

D) To install the new o-ring, push one section of the o-ring into the groove with your thumb or a soft roller, then push the section 180° opposite from the first into the groove. Continue by pushing in the o-ring at points 90° to the original sections. Finally, push the rest of the ring into the groove.

E) Rub the o-ring in a circular motion in the groove with your thumb to even-out any bumps.

RE-ASSEMBLY:

1) Reinstall the check ball (or the check disc on 10" and larger valves), spring and the spring retainer into the disc guide.

2) Stake the outside of the spring retainer at four (4) places to lock it in place.

3) Install new guide ring. Coat new seal ring with general purpose lithium grease and install on Disc Guide with the open side of the "U" facing up toward the compression chamber. The seal ring will fit tightly over the Disc Guide, so be careful not to distort it or damage its sealing edges.

4) Seat Installation

A) DROP-IN SEAT:

- i) Press bushing into body.
- ii) Place spring, (large end first for conical springs) into the body.
- iii) Install the body o-ring if the valve contains a "Full Face" seat.
- iv) Apply a coating of grease to the seal ring and guide ring.
- v) Lower the disc/disc guide/seat assembly into the body and install the retaining screws.

5) Stroke the disc to work the valve a couple of times to check for free disc movement. The valve should close in the horizontal orientation.

6) Re-install the valve in the line with the flow arrow on the body pointing in the direction of flow.

SCV[®] MAINTENANCE PROCEDURES

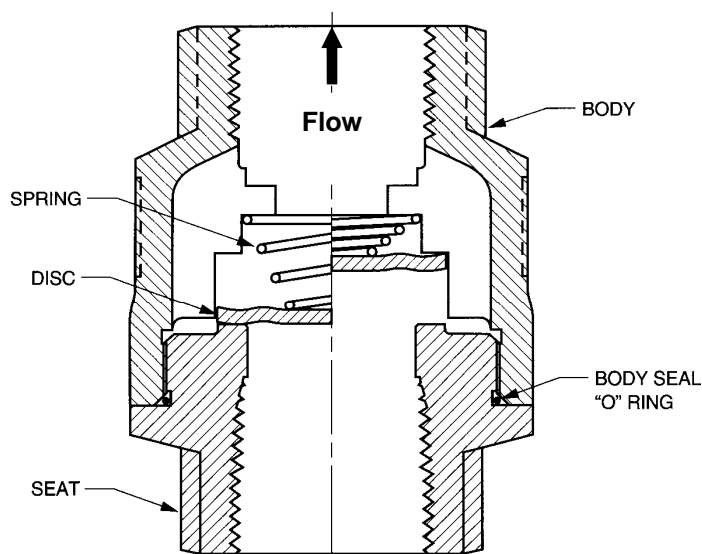

WARNING: If the system fluid is hazardous, take appropriate precautions. Make sure to bleed off pressure from the line before removing the valve. Hold the valve by the Hex end nearest to the mating pipe and loosen. Again, do not hold the valve by the opposite end, as this may loosen the valve body joint.

Do not allow any pipe thread sealants or tape to be forced into the valve operating area or become lodged on the valve sealing surfaces. This could affect the performance of the valve.

DIS-ASSEMBLY:

- 1) Place the outlet Hex end of the valve in a vice or other suitable fixture.
- 2) Unscrew the seat from the body and remove the disc and spring.

3) Inspection:

Seating surfaces may be cleaned using a soft cloth and an appropriate solvent. Avoid scratching the seating surface. Check for scratches on the seating surfaces. If they can be felt with your fingernail, recondition or replace the disc and/or seat. Check the disc and guide ribs for signs of wear. If the total disc/rib clearance exceeds 1/16", replace the valve. Inspect the body o-ring for signs of cracking or ruptures. Replace it if necessary.

SOFT SEATING: For valves with an o-ring soft seat, inspect the o-ring and replace if cracked or excessively deformed.

4) Soft Seat Replacement:

- A) To replace the o-ring, pry it out of the groove using a thin piece of metal (a .005" thick feeler gage works well) taking care not to scratch the bottom of the o-ring groove.
- B) Clean out the groove.
- C) Lubricate a new o-ring with water soluble lubricant such as dishwashing detergent.
- D) To install the new o-ring, push one section of the o-ring into the groove with thumb or a soft roller, then push the section 180° opposite from the first into the groove. Continue by pushing in the o-ring at points 90° to the original sections. Finally push the rest of the ring into the groove.
- E) Rub the o-ring in a circular motion in the groove with your thumb to even-out any bumps.

RE-ASSEMBLY:

- 1) Place the spring into the body, large end first, then the disc with the side marked "spring side" against the disc.
- 2) Clean all the threads of the seat and coat with an anti-seize compound.
- 3) Install the new body o-ring in the thread undercut of the seat.
- 4) While holding the disc down in the body, and compressing the spring, screw the seat into the body.
- 5) Tighten to 200 ft-lbs. for 1" and larger units, 100 ft-lbs. for 3/4" and 1/2" units and 50 ft-lbs. for 1/4".
- 6) Lift the disc to work the valve a couple of times to check for free disc movement.
- 7) Reinstall the valve in the line with the flow arrow on the body pointing in the direction of flow.

Caution: Do not allow any pipe thread sealants or tape to be forced into the valve operating area or become lodged on the valve sealing surfaces.

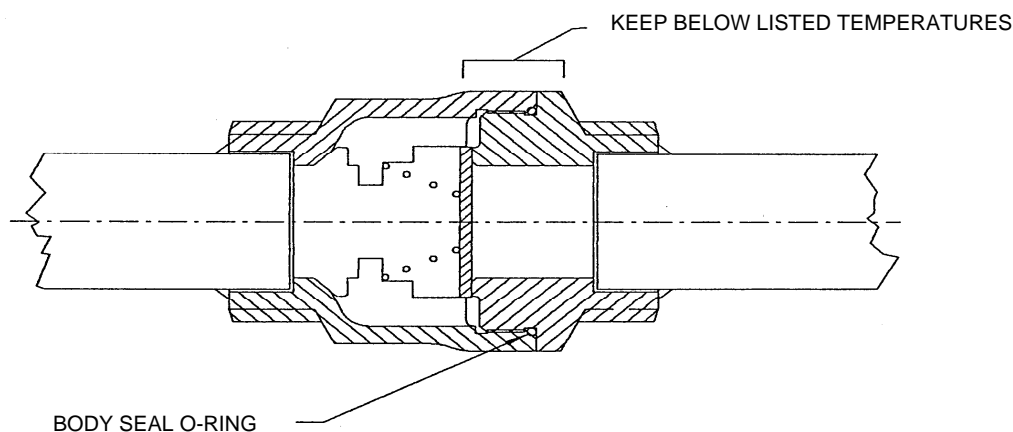
WELDING PRECAUTION FOR SOCKET WELD SCV CHECK VALVES

When welding the check valve into the line, avoid heating the marked body joint region above the temperatures listed below. Damage to the body seal (or optional soft seat) o-ring may result.

O-Ring Material	Max. Temperature
Buna-N	250°F
Chemraz®	450°F
EPDM	300°F
Kalrez®	600°F
Teflon® Encapsulated Viton®	400°F
Viton®	400°F
Zelon (1)	470°F (750 CWP SCV) 400°F (3600 CWP SCV)

Notes: 1. Standard O-ring for the 750 CWP SCV and 3600 CWP SCV.

SCV-R® MAINTENANCE PROCEDURES

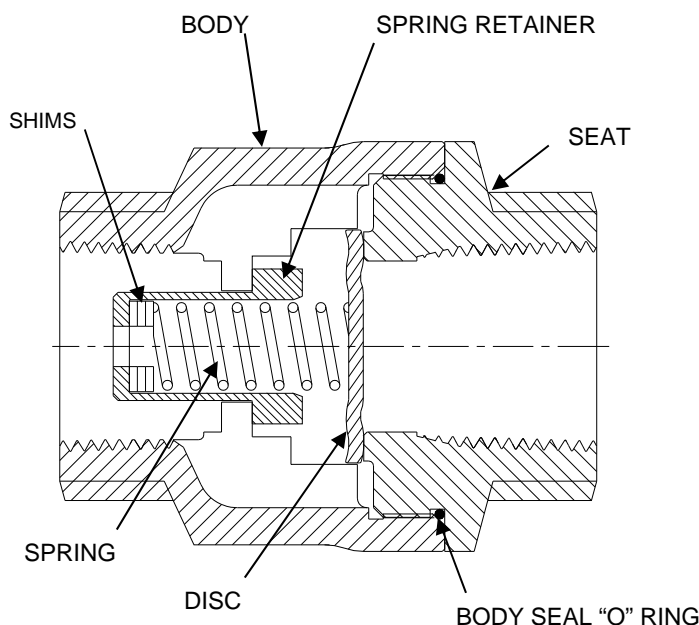

WARNING: If the system fluid is hazardous, take appropriate precautions.

CAUTION: The spring cracking pressure inside the valve can range from 1 psi to 25 psi. Use caution with disassembly.

Make sure to bleed off pressure from the line before removing the valve. Hold the valve by the Hex end nearest to the mating pipe and loosen. Again, do not hold the valve by the opposite end, as this may loosen the valve body joint.

Do not allow any pipe thread sealants or tape to be forced into the valve operating area or become lodged on the valve sealing surfaces. This could affect the performance of the valve.

DIS-ASSEMBLY:

1) Place the outlet Hex end of the valve in a vice or other suitable fixture oriented vertically.

2) Unscrew the seat from the body and remove the disc, spring, spring retainer, shim(s) if included and body O-ring.

3) Inspection:

Seating surfaces may be cleaned using a soft cloth and an appropriate solvent. Avoid scratching the seating surface. Check for scratches on the seating surfaces. If they can be felt with your fingernail, recondition or replace the disc and/or seat. Check the disc and guide ribs for signs of wear. If the total disc/rib clearance exceeds 1/16", replace the valve. Inspect the body o-ring for signs of cracking or ruptures. Replace it if necessary.

SOFT SEATING: For valves with an o-ring soft seat, inspect the o-ring and replace if cracked or excessively deformed.

4) Soft Seat Replacement:

- A) To replace the o-ring, pry it out of the groove using a thin piece of metal (a .005" thick feeler gage works well) taking care not to scratch the insidewall of the o-ring groove.
- B) Clean out the groove.
- C) Lubricate a new o-ring with water soluble lubricant such as dishwashing detergent.
- D) To install the new o-ring, push one section of the o-ring into the groove with thumb or a soft roller, then push the section 180° opposite from the first into the groove. Continue by pushing in the o-ring at points 90° to the original sections. Finally push the rest of the ring into the groove.
- E) Rub the o-ring in a circular motion in the groove with your thumb to even-out any bumps.

RE-ASSEMBLY:

- 1) With the body oriented vertically and the outlet down, place the spring retainer into the body followed by the shim(s) if included.
- 2) Place the spring into the spring retainer.
- 3) Place the disc with the side marked "spring side" against the spring.
- 4) Clean all the threads of the seat and coat with an anti-seize compound.
- 5) Install the new body o-ring in the thread undercut of the seat.
- 6) While holding the disc down in the body, and compressing the spring, screw the seat into the body.
- 7) Tighten to 200 ft-lbs. for 1" and larger units, 100 ft-lbs. for 3/4" and 1/2" units and 50 ft-lbs. for 1/4".
- 8) Lift the disc to work the valve a couple of times to check for free disc movement.
- 9) Reinstall the valve in the line with the flow arrow on the body pointing in the direction of flow.

Caution: Do not allow any pipe thread sealants or tape to be forced into the valve operating area or become lodged on the valve sealing surfaces.

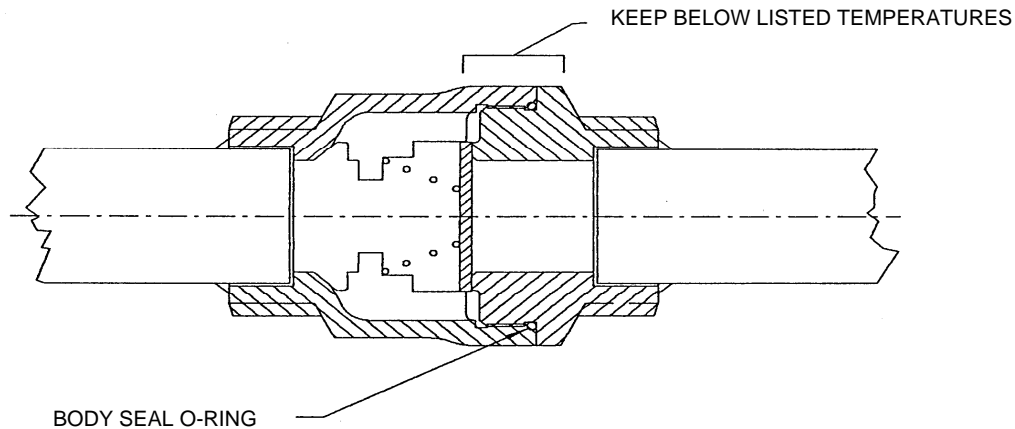
WELDING PRECAUTION FOR SOCKET WELD SCV-R® CHECK VALVES

When welding the check valve into the line, avoid heating the marked body joint region above the temperatures listed below. Damage to the body seal (or optional soft seat) o-ring may result.

O-Ring Material	Max. Temperature
Buna-N	250°F
Chemraz®	450°F
EPDM	300°F
Kalrez®	600°F
Teflon® Encapsulated Viton®	400°F
Viton®	400°F
Zelon (1)	470°F (750 CWP SCV) 400°F (3600 CWP SCV)

Notes: 1. Standard O-ring for the 750 CWP SCV and 3600 CWP SCV.

TLW[®] MAINTENANCE PROCEDURES

INSTALLATION:

1. Thread flange studs until they bottom out in the valve body. The studs are designed for 1.5x diameter thread depth into the valve body.
2. If the valve has a split face design on the valve inlet side (2" to 8" 150 & 300 only - seat and body each make up a portion of the raised face of the flange), ensure that the gasket used completely covers the split (see page 27).
3. Follow bolting and torque recommendations based on the type of gasket used. See link 150/300 Bolting Torque - <https://www.gasketresources.com/torque-value-display>
4. Locate the flow arrow on the valve nameplate or valve body. Ensure that the valve body is bolted in line with the flow arrow pointing in the same direction as the flow in the piping.

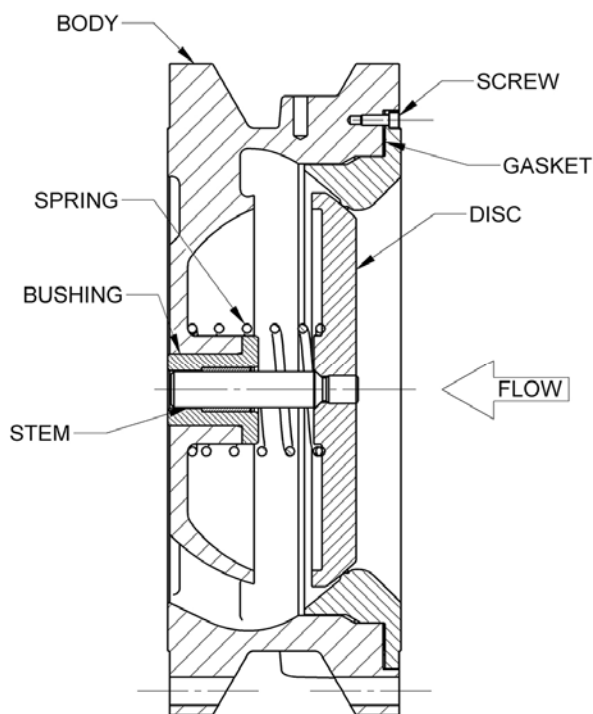

VALVE DIS-ASSEMBLY:

1. There are two different seat designs for the TLW style check valve: threaded seat and slip in seat.
 - A: Threaded Seat:
 - A.1 Unscrew the seat counterclockwise to remove the seat from the valve body.
 - B: Slip-in Seat:
 - B.1 Using a screwdriver, remove the seat retaining screws from the valve body.
 - B.2 Pull the seat straight out of the valve body.
 - B.3 Remove the seat gasket and discard it. NOTE: It is recommended that the seat gasket be replaced every time the valve is disassembled.
2. Once the seat is removed from the valve body, grasp the valve stem and pull the stem/disc assembly straight out of the valve body.
3. Remove the spring from the valve body.
4. The bushing is press fit into the valve body. If it is necessary to remove it, it will need to be driven out from the outlet side of the valve body. Use a hammer and a punch to drive the bushing out of the valve body. Be sure to support the opposite side of the hub prior to driving out the bushing.

INSPECTION:

1. Inspect the seating surfaces of the seat and disc. The seat and disc may be lapped with a suitable fine grade lapping compound.
2. **Soft seat only:** For valves with an O-ring soft seat, inspect the O-ring for cracking or deformation. Replace the O-ring if it is cracked or deformed.
3. Remove any scale buildup on the stem or bushing.
4. Inspect the spring for signs of cracking or material removal due to corrosion.

REFACING SEATING SURFACES:Metal-to-Metal seating:

1. For scratches, cuts, and defects less than approximately .01" deep, seat and disc seating faces may be lapped with a suitable fine grit lapping compound.
2. For scratches, cuts and defects greater than .01" deep, a total of .03" per surface has been provided on the seat and disc to permit re-facing when necessary. It is important that the seating faces remain perpendicular to the axis of the parts. The surface finish should be 32 Ra or better. Then lap as necessary.

Soft seating:

1. The disc may be refaced as described above. The seat face should not be refaced. If the soft seat O-ring groove is damaged, the entire seat must be replaced.
2. To replace the soft seat O-ring, carefully pry the O-ring out of the groove using a thin piece of metal or a pick. (a thin feeler gauge works well). Take care not to scratch the bottom of the O-ring groove.
3. Clean out the groove using a suitable solvent.
4. To install the new O-ring, begin by carefully pushing one section of the O-ring into the groove using your thumb or a soft roller. Then push another section of the O-ring into the groove 180° around the groove from the first section. Continue pushing in sections at points 90° from the first section. Working your way around the entire groove, continue pushing sections of the O-ring into the groove evenly. Once the entire O-ring seems to be in the groove, use your thumb or a roller and push all the way around the O-ring groove to smooth out any bumps and firmly seat the O-ring.

RE-ASSEMBLY:

1. Lay the valve body down on a solid surface with the inlet (seat end) of the valve facing up.
2. If the bushing was removed, the new bushing will have to be press-fit into the valve body. To press fit in the bushing, place the valve body on a surface ensuring that the ribs and hub are adequately supported. Use a press or hammer the bushing into position. Be careful not to mar the inside diameter of the bushing where the stem slides.
3. Install the spring. Depending upon the size and class of the valve either a conical or helical spring will be used. Pay attention to the orientation during disassembly or review the valve assembly drawing prior to installation.
4. Slide the stem/disc assembly into the valve body. If applicable, the larger diameter end of the stem slides into the bushing. Ensure that the stem slides freely in the bushing.

5. Install the seat back into the valve body

A. Threaded seat:

- A.1 Apply anti-seize to the threaded portion of the seat.
- A.2 Ensuring that the small diameter end of the valve stem engages with the hole in the seat, slowly thread the seat into the valve body. While threading the seat into the valve body, push down on the disc, compressing the spring, to keep the seating portion of the disc from scarring the seat.
- A.3 Tighten the seat until snug. There is no need for excessive torque.

B. Slip-in seat:

- B.1 It is recommended that the seat gasket be replaced every time the valve is disassembled. Place a new gasket into the groove in the valve body.
- B.2 Ensuring that the end of the valve stem engages the hole in the seat, slide the seat into the valve.
- B.3 Replace the seat retaining screws. NOTE: These screws are only meant to retain the seat during transit and installation of the valve. These screws are not meant to compress the seat and load the seat gasket.

WLC® MAINTENANCE PROCEDURES

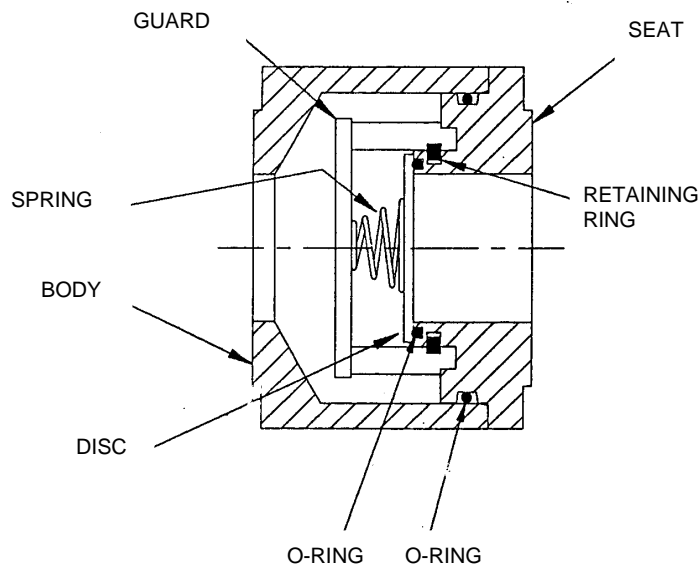

**(Old Design)
1 and 1-1/2" WLC**

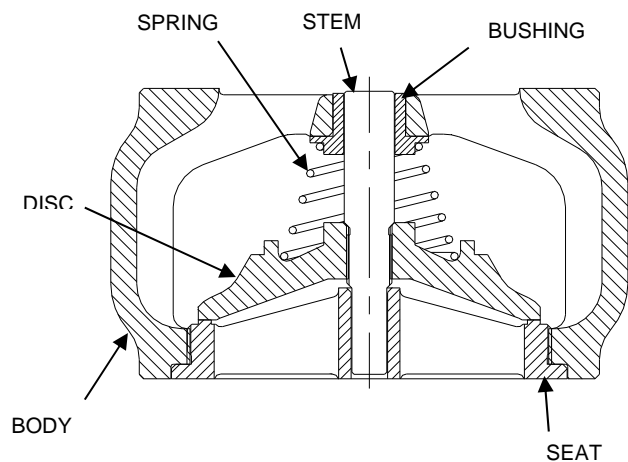

2" and larger WLC

DIS-ASSEMBLY:

1) Remove the seat from the valve. There are three (3) different seat designs for the WLC:

A) 1-1/2" AND SMALLER:

- i) Pull the seat from the body. The seat is only held in by the friction of the body o-ring seal. All internal parts will come out with the seat.
- ii) With a pair of pliers, squeeze the ends of the retaining ring together to release the guard and lift it off the seat.
- iii) Remove the disc and spring.

B) 2" AND LARGER WITH RAISED FACE:

- i) Unscrew the seat (or remove the retaining set screws on cast iron units and lift out the seat).
- ii) The disc/stem, spring, and bushing can be easily removed by hand.

C) 2" AND LARGER WITH RTJ ENDS:

- i) From the outlet end, drive the stem with a soft metal or plastic drift. This will push the disc/stem and seat out the inlet end.
- ii) Remove the spring, bushing and body seal o-ring.

2) Inspection:

Inspect the seating surfaces, bushing and seat guide (and guard on 1-1/2" and smaller) for wear. The seat and disc may be lapped with a suitable fine grade lapping compound. Remove any scale build up on the stem and guides. Replace the trim if total stem-to-bushing or seat guide clearance (or disc-to-guard leg on 1-1/2" and smaller units) exceeds 1/16".

SOFT SEATING: For valves with an o-ring soft seat, inspect the o-ring and replace if cracked or excessively deformed.

3) Refacing:

A) METAL TO METAL SEATING: A total of .03" metal per surface has been provided on the seat and disc to permit refacing when necessary. It is important that the facing remain perpendicular to the axis of the parts. The finish should be 32 Ra or better.

B) SOFT SEATING: The disc may be refaced as outlined above. The seat CANNOT be refaced; if the o-ring groove is damaged, replace the trim. It is acceptable for the contact surface of the seat to have small scratches and/or pits, provided the groove is undamaged.

4) Soft Seat Replacement:

A) To replace the ring, pry it out of the groove using a thin piece of metal (a .005" thick feeler gage works well) taking care not to scratch the bottom of the o-ring groove.

B) Clean out the groove. Lubricate a new o-ring with water soluble lubricant such as dishwashing detergent or suitable lubricant compatible with the process fluid.

C) To install the new o-ring, push one section of the o-ring into the groove with your thumb or a soft roller, then push the section 180° opposite from the first into the groove. Continue by pushing in the o-ring at points 90° to the original sections. Finally, push the rest of the ring into the groove.

D) Rub the o-ring in a circular motion in the groove with your thumb to even-out any bumps.

RE-ASSEMBLY:**1) Seat Installation**

There are three (3) different seat designs for the WLC:

A) 1-1/2" AND SMALLER (Old Design):

- i) Place retaining ring in groove of seat.

- ii) Place spring, small end first, onto guard spring hub.
- iii) Position the disc over the spring and between the four guard legs.
- iv) While holding the disc and spring in the guard with one hand, compress the retaining ring with suitable pliers into the seat groove with the other, then position the disc/spring/guard over the seat with the notches in the guard legs aligned with the retaining ring and release the retaining ring, locking the guard onto the seat.
- v) Lift the disc to work the valve a couple of times to check for free disc movement.

B) 2" AND LARGER WITH RAISED FACE:

- i) Install the guide bushing.
- ii) Place the spring (small end for conical springs) on the guide bushing shoulder.
- iii) Insert the disc/stem assembly.
- iv) Coating the seat threads with anti-seize compound is recommended. Then screw in seat until locked. (Drop in the seat and re-install the retaining set screws for cast iron units.)

C) 2" AND LARGER WITH RTJ ENDS:

- i) Install the guide bushing.
- ii) Place the small end of the spring on the guide bushing shoulder.
- iii) Insert the disc/stem assembly.
- iv) Install the body o-ring.
- v) Press in seat until bottomed. (If seat is not tight, remove and re-stake the O.D. of the seat with a sharp point punch at 3 or 4 places to create interference points, then press seat back into body.)

2) Re-install the valve in the line with the flow arrow on the body pointing in the direction of flow.

END FLANGE GASKET ILLUSTRATION

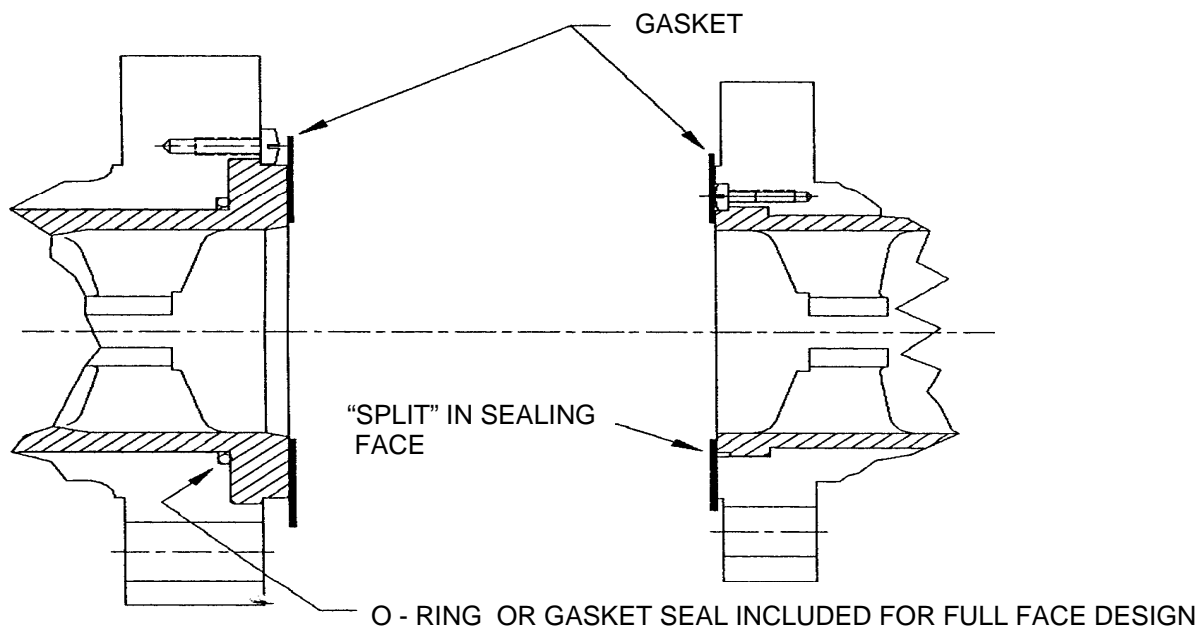

FULL FACE SEAT (Current design)
(3" ANSI 600 FLANGE SHOWN)

SPLIT FACE SEAT (Current design)
(Found on 1" and 1 1/2" GLC[®]s, WLC[®]s,
and 2" to 8" ALC[®]s)

WAFFER GASKET ILLUSTRATION

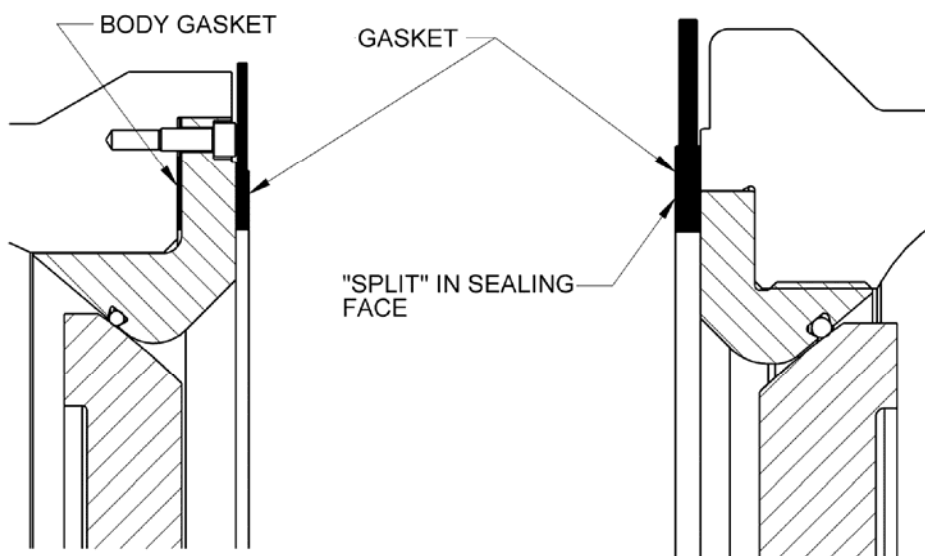

FULL FACE SEAT (Current design)

SPLIT FACE SEAT (Current design)
(Found on WLC[®]s and 2" to 8" ALC[®]s)

Other DFT® Publications

All DFT Literature is available by download on our website

[Visit us at dft-valves.com](http://dft-valves.com)

Full In-Line Check Valve Catalog/Product Selection Guide

6-Page In-Line Check Valve Brochure/Product Selection Guide

Severe Service Control Valve Catalog/Product Selection Guide

“The Misunderstood Check Valve” article. VMA Magazine July 2006

[Individual Cut Sheets are also available for download on the DFT website](#)

Hastelloy® is a Registered Trademark of Haynes International Inc.; Inconel® and Monel® are Registered Trademarks of Huntington Alloys Corporation; Nitronic® is a Registered Trademark of AK Steel Corporation; Stellite® is a Registered Trademark of Kennametal Inc.; Tuf-Flex® is a Registered Trademark of Rubber Fab Inc.; Teflon® and Viton® are Registered Trademarks of Chemours Company FC, LLC; Rulon® is a registered Trademark of Saint-Gobain Performance Plastics Corp. ALC®, Basic-Check®, DFT®, DLC®, DSV®, Excalibur®, FBC®, GLC®, PDC®, SCV®, SCV-R®, TLW®, WLC®, Y-Calibur®, Zelon® are Registered Trademarks of DFT Inc. BNC™ and The Check Valve Doctor™ are trademarks of DFT Inc. All other trademarks are the properties of their respective owners and are used for purposes of identification only.