

MH225

MATERIAL HANDLING | MACHINE TENDING | PRESS TENDING

KEY BENEFITS

Small mounting surface and minimum interference radius save valuable floorspace

Optimized robot design with increased speed reduces cycle time

Increased payload, moment and inertia ratings allow the robots to be used in a wide variety of applications

Slim wrist profile for high density spacing and for reaching into confined spaces

SPECIFICATIONS

225 kg payload (MH225)

2,702 mm horizontal reach

3,393 mm vertical reach

±0.2 mm repeatability

Floor mounted

CONTROLLERS



DX200



MLX300*

- Powerful six-axis handling robot features high-rigidity speed reducers and high-speed motion which reduce cycle times.
- The MH225 features increased payload capacity as well as increased speed of each axis over previous models.
- High payload and increased moment and inertia ratings allow the robot to handle larger and heavier payloads.
- Streamlined upper arm design features a slim wrist profile and reduces robot width by over 200 mm. This allows easier reach into confined spaces, improving application flexibility.
- Base design reduces robot interference radius to only 515 mm, the lowest in its class. This allows the robot to be mounted closer to machines and fixtures, making best use of valuable floorspace.
- Improved design removes the counterbalance from robot base. This reduces the mass of the arm, enabling higher acceleration, deceleration and speed.
- The required mounting surface is reduced by nearly 44%, saving valuable floor space and making the robot easier to apply.
- Up to 70% less power consumption during motion and 25% savings during idle periods compared to previous models.
- Cables and air lines are routed through robot base to upper arm to increase cable life, enhance safety and reduce teaching time.
- Cable installation tube in the base of the robot facilitates fieldbus routing to the robot upper arm and/or gripper.
- Pre-wired for servo gripper which allows a wider range of product handling.
- The MH225 has an IP67-rated wrist and an IP54-rated body.

MH225 ROBOT

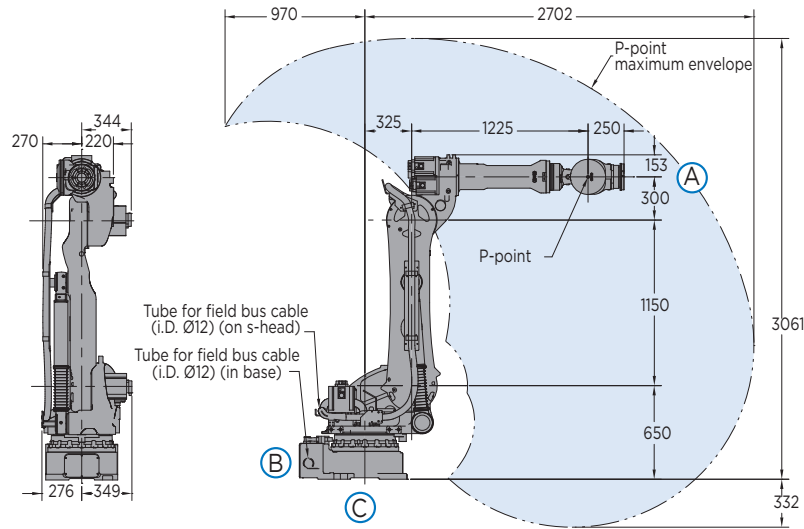

VIEW A

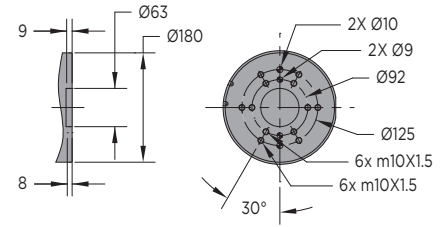

VIEW B

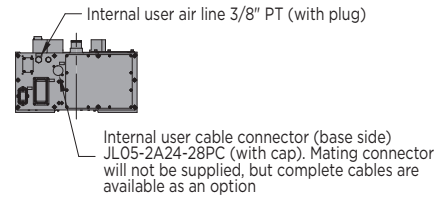

VIEW C

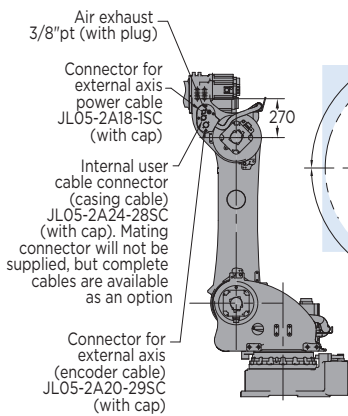
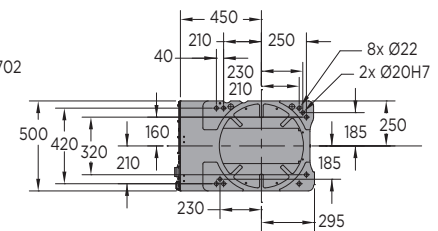

All dimensions are metric (mm) and for reference only.
Request detailed drawings for all design/engineering requirements.

SPECIFICATIONS: MH225

| Axes | Maximum motion range [°] | Maximum speed [°/sec.] | Allowable moment [N•m] | Allowable moment of inertia [kg•m ²] | Controlled axes | 6 |
|------|--------------------------|------------------------|------------------------|--|---|--------------------------------------|
| S | ±180 | 120 | - | - | Maximum payload [kg] | 225 |
| L | +76/-60 | 97 | - | - | Repeatability [mm] | ±0.2 |
| U | +90/-147 | 115 | - | - | Horizontal reach [mm] | 2,702 |
| R | ±360 | 145 | 1,372 | 145 | Vertical reach [mm] | 3,393 |
| B | ±125 | 145 | 1,372 | 145 | Weight [kg] | 1,000 |
| T | ±360 | 220 | 735 | 84 | Power requirements | 3-phase; 240/480/575 VAC at 50/60 Hz |
| | | | | | Power rating [kVA] | 5.0 |
| | | | | | Internal I/O cable [conductors w/ ground] | 24 |
| | | | | | Internal air line [connections] | (1) 3/8" |

* The MLX300 software option is not available for use with arc or spot welding, coating, dispensing, cutting or other "path control" applications. MLX300 fieldbus cards, I/O cards and vision equipment must be purchased separately from the supplier. All peripherals are programmed using a PLC.

OPTIONS

- Extended length manipulator cables
- Robot risers and base plates
- External axis kits
- Wide variety of fieldbus cards
- Vision systems
- Robot base and upper arm I/O cables

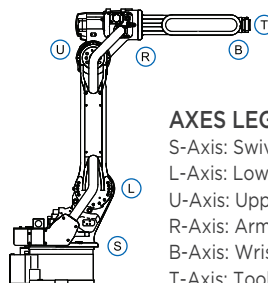

AXES LEGEND

- S-Axis: Swivel Base
- L-Axis: Lower Arm
- U-Axis: Upper Arm
- R-Axis: Arm Roll
- B-Axis: Wrist Bend
- T-Axis: Tool Flange

Yaskawa America, Inc.
Motoman Robotics Division

100 Automation Way
Miamisburg, OH 45342
Tel: 937.847.6200
Fax: 937.847.6277

motoman.com

YASKAWA