

MPL100 II

PALLETIZING

KEY BENEFITS

Improve cycle times for palletizing and other order-handling tasks

High reliability and ease of maintenance

Performance-driven design

SPECIFICATIONS

Payload:
100 kg with cabling flange
115 kg without cabling flange

3,149 mm vertical reach

2,150 mm horizontal reach

±0.2 mm repeatability

CONTROLLERS



DX200



MLX300*

- High-performance, 5-axis robot with 100 kg payload capacity and ±0.2 mm repeatability.
- Highly versatile, this robot is ideal for case palletizing, bag palletizing, pallet handling, order picking and many logistical tasks for end-of-line or distribution center automation.
- Extensive 3,149 mm vertical reach combined with 2,150 mm horizontal reach enables this robot to build 102 in. tall trailer-high loads on standard 48 in. x 40 in. pallet.
- T-axis features high allowable moment of inertia; asymmetric loads are handled effectively without compromising speed or performance.
- Cable installation tube in robot base facilitates fieldbus routing to the upper arm and/or gripper.
- NSF-H1 certified food-grade lubricant option available for food or consumer product packaging environment.
- Available with PalletSolver™, Yaskawa Motoman's operator-friendly palletizing software suite for fast and easy creation of palletizing patterns.
 - PalletSolver's offline pattern generation tool with intuitive graphical interface allows quick changeovers without halting production.
 - Highly customizable to each palletizing system.
 - Directly imports pallet patterns generated in widely-used TOPS® or CAPE software.

MPL100 II ROBOT

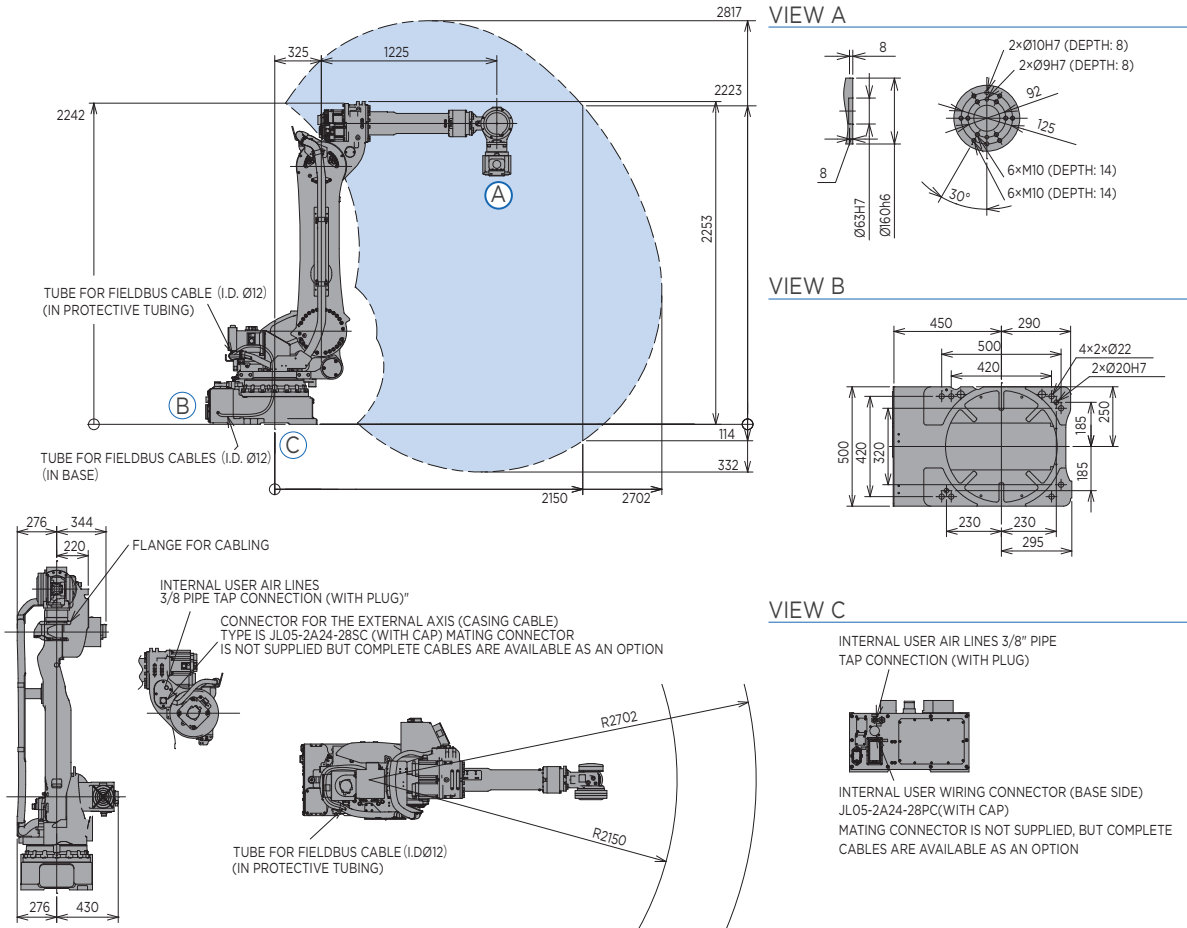

All dimensions are metric (mm) and for reference only.
Request detailed drawings for all design/engineering requirements.

SPECIFICATIONS (WITH CABLING FLANGE)

Axes	Maximum motion range [°]	Maximum speed [°/sec.]	Allowable moment [N•m]	Allowable moment of inertia [kg•m ²]	Controlled axes	5
S	±180	125	-	-	Maximum payload [kg]	100
L	-60/+76	88	-	-	Repeatability [mm]	±0.2
U	-147/+40	125	-	-	Horizontal reach [mm]	2,150
B	+15**	175	196	88	Vertical reach [mm]	3,149
T	±210**	265	0	55	Protection (IP rating)	IP54
					Weight [kg]	950
					Power requirements	3-phase; 240/480/575 VAC at 50/60 Hz
					Power rating [kVA]	8

* The MLX300 software option is not available for use with arc or spot welding, coating, dispensing, cutting or other "path control" applications.
MLX300 fieldbus cards, I/O cards and vision equipment must be purchased separately from the supplier. All peripherals are programmed using a PLC.

** Motion range limited by cabling flange

OPTIONS

NSF-H1 certified food-grade lubricants
Extended length manipulator cables
PalletSolver - revolutionary palletizing software
MotoSight™ - easy to integrate vision software
Robot risers and base plates
Wide variety of fieldbus hardware

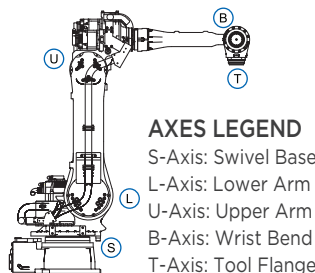

Yaskawa America, Inc.
Motoman Robotics Division

100 Automation Way
Miamisburg, OH 45342
Tel: 937.847.6200
Fax: 937.847.6277

motoman.com

YASKAWA