

ES165RD II ES200RD II

MATERIAL HANDLING | MACHINE TENDING | PRESS TENDING

KEY BENEFITS

Versatile, high-performance robot for heavy-payload machine or press tending and other handling tasks

Enhanced safety with control reliable software for guarding (FSU)

Energy efficient design of DX200 versus previous controllers

SPECIFICATIONS

165 kg payload (ES165RD II)

200 kg payload (ES200RD II)

3,140 mm horizontal reach

4,782 mm vertical reach

±0.2 mm repeatability

CONTROLLERS



DX200



MLX300*

- High-speed six-axis ES165RD II and ES200RD II shelf-mounted robots set standard for versatility in large robot market.
- Designed to provide superior performance in machine and press tending, and other heavy-payload applications.
- Used for loading and unloading of parts, these robots can help eliminate inconsistencies of a manual process for applications such as turning, milling and grinding.
- Ideal for “jigless” applications where robot positions parts for processing by other robots, or two robots handle a single part.
- Ability to handle all types of material including ceramics, composites, metals and polymers.
- Shelf mounting saves floorspace, expands work envelope and improves access to parts.
- Compact, slim design allows robots to reduce cycle time and reach into confined spaces, improving system productivity.
- Large work envelope and high moment of inertia ratings accommodate a wide range of large, heavy parts.
- Fast axial speeds and acceleration reduce cycle times and increase production output.
- Pre-wired for servo gripper use, which allows a wider range of product handling.
- Robust controller integration provides enhanced safety and Functional Safety Unit (FSU) through control reliable safeguarding within the robot software.
- Up to 70% less power consumption during motion and 25% savings during idle periods compared to previous models.
- Cables and air line for end effector are routed through robot base to upper arm to increase cable life, enhance safety and reduce teaching time.
- Floor-mounted versions (ES165D II and ES200D II) available.

ES165RD II | ES200RD II

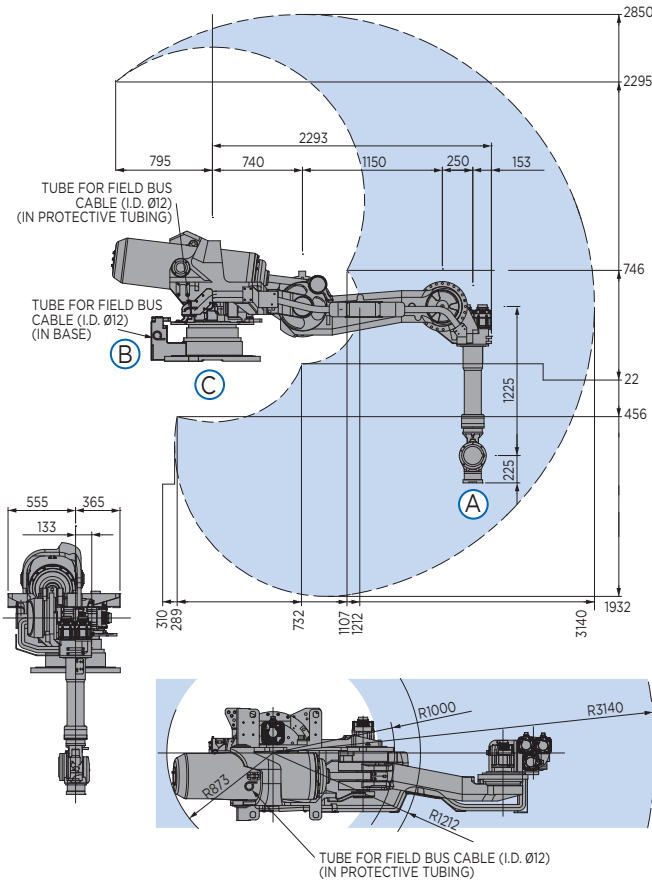

VIEW A

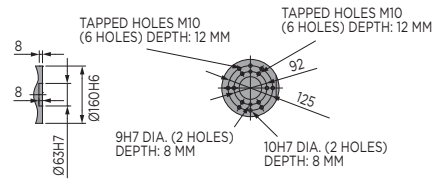

VIEW B

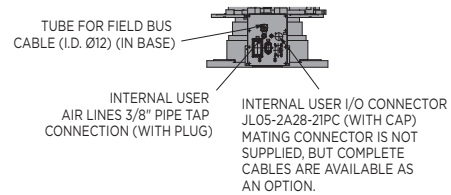

VIEW C

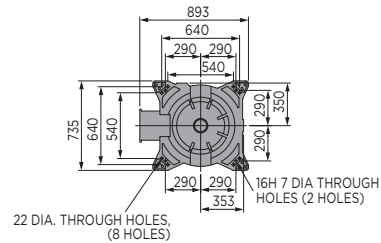

All dimensions are metric (mm) and for reference only.
Request detailed drawings for all design/engineering requirements.

SPECIFICATIONS: ES165RD II | ES200RD II

Axes	Maximum motion range [°]		Maximum speed [°/sec.]		Allowable moment [N•m]		Allowable moment of inertia [kg•m ²]		Controlled axes	ES165RD II	ES200RD II
	ES165RD II	ES200RD II	ES165RD II	ES200RD II	ES165RD II	ES200RD II	ES165RD II	ES200RD II			
S	±180	±180	105	90	-	-	-	-	6	6	6
L	+80/-130	+80/-130	105	85	-	-	-	-	165	200	200
U	+208/-112	+208/-107	105	85	-	-	-	-	±0.2	±0.2	±0.2
R	±360	±360	175	120	921	1,344	85	143	3,140	3,140	3,140
B	±130	±125	150	120	921	1,344	85	143	4,782	4,782	4,782
T	±360	±360	240	190	490	715	45	80	1,730	1,800	1,800
									Power requirements	3-phase; 240/480/575 VAC at 50/60 Hz	3-phase; 240/480/575 VAC at 50/60 Hz
									Power ratings [kVA]	5	5
									Internal I/O cable [conductors w/ ground]	24	24
									Internal air line [connections]	(1) 3/8"	(1) 3/8"

* The MLX300 software option is not available for use with arc or spot welding, coating, dispensing, cutting or other "path control" applications.
MLX300 fieldbus cards, I/O cards and vision equipment must be purchased separately from the supplier. All peripherals are programmed using a PLC.

OPTIONS

- Extended length manipulator cables
- Robot risers and base plates
- Wide variety of fieldbus cards
- MotoSight™ 2D and 3D vision systems
- Robot base and upper arm I/O cables

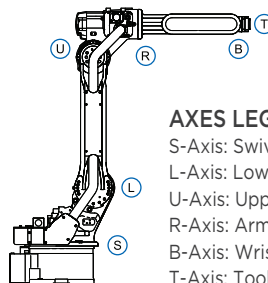

AXES LEGEND

- S-Axis: Swivel Base
- L-Axis: Lower Arm
- U-Axis: Upper Arm
- R-Axis: Arm Roll
- B-Axis: Wrist Bend
- T-Axis: Tool Flange

Yaskawa America, Inc.
Motoman Robotics Division

100 Automation Way
Miamisburg, OH 45342
Tel: 937.847.6200
Fax: 937.847.6277

motoman.com

YASKAWA