

| Standards   |         |
|---|---------|
| GenICam compatible<br>compatible with most 3rd party software | GenICam |
| PV  | PV      |
| US3   | US3     |
| MIK   | MIK     |
| CXP   | CXP     |
| PCOL  | PCOL    |
| GENICAM   | GENICAM |
| GENICAM   | GENICAM |

| I/O Features   |                              |
|--|------------------------------|
| up to 4 x open drain outputs   | 4 x open drain outputs       |
| strobe controller - incandescent LED light driver/controller, up to 3 A - external synchronization | 4 x open drain outputs       |
| sequencer - up to 16 programmable intervals with individual exposure and strobe out                | up to 4 x open drain outputs |
| programmable logic I/O functionality with timers   | 4 x open drain outputs       |
| PWM - high frequency pulse width modulation  | 4 x open drain outputs       |
| signal sink through high-low filter, debouncer and prescaler for trigger input                     |                              |
| versatile I/O concept: 24V signal levels - RS232 / RS422 differential signal                       |                              |

| Camera Firmware Features   |                                    |
|--|------------------------------------|
| 2 x 2 binning  | 2 x 2 binning (4 x 4 for CI)       |
| horizontal and vertical image flip                               |                                    |
| custom defect pixel correction - custom defect pixel mapping     | shading correction for GigE Vision |
| AOI / ROI (area of interest / region of of interest)             |                                    |
| read out control - custom acquisition timing (manual or delayed) |                                    |
| white balance (manual / auto)                                    |                                    |
| exposure time control (manual, auto or external)                 |                                    |
| gain (manual or auto)  |                                    |
| adjustable offset  |                                    |
| PV - particle image velocity (CD sensors only)                   |                                    |
| LUT (look up table) - custom pixel mapping                       |                                    |
| trigger mode (internal, software or external)                    |                                    |
| integrated temperature sensor - SIM accessible                   |                                    |

| Camera Hardware Features |                        |   |
|--------------------------|------------------------|---|
| 64 MB internal memory    | 256 MB internal memory | GigE Vision, Camera Link or USB3 Vision                 |
| 8 or 12 bit pixel format |                        |   |
| C or CS Mount            | C Mount or MFT         | PCoE (Power over Camera Link) C, AMZ (FEI 11.48) or MFT |
|                          |                        | lens Mount Adapters available                           |
| 38 x 38 x 33 mm          | 38 x 38 x 45 mm        | optional Dynamic Lens Control available                 |
| IP Class up to IP67      |                        | 50 x 50 x (43-47) mm                                    |
|                          |                        | 50 x 50 x 46 mm   |
|                          |                        | 70 x 71 x 55 mm   |
|                          |                        | 80 x 80 x 60 mm   |
|                          |                        | precision mechanical housing                            |
|                          |                        | manual or auto tap balancing                            |
|                          |                        | pixel clock setting for Camera Link                     |

| Sensor                  |  |  |   |                  |                  |
|-------------------------|--|--|---|------------------|------------------|
| 0.3 to 5 Mpixel         | 1 to 12 Mpixel                                       | 2.3 to 12 Mpixel                                       | 1 to 12 Mpixel  | 10 to 29 Mpixel  | 47 Mpixel        |
| CD                      | CD   | CMOS and CD  | CMOS and CD   | CMOS and CD      | CD               |
| Sony 1 tap sensors      | Sony and ON Semiconductor 1 and 2 tap sensors        | Sony, ON Semi and CMOS 1, 2 and 4 tap / 8 data sensors | Sony and ON Semiconductor 1, 2 and 4 tap / 32 channel sensors | ON Semiconductor | ON Semiconductor |
| mono and color versions | progressive scan or global shutter (image on demand) |  |   |                  |                  |



## Feature List

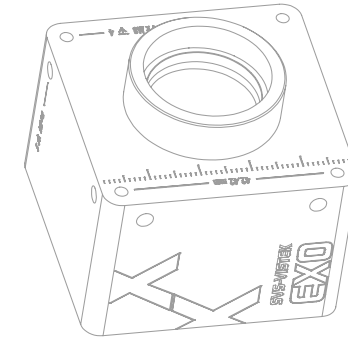
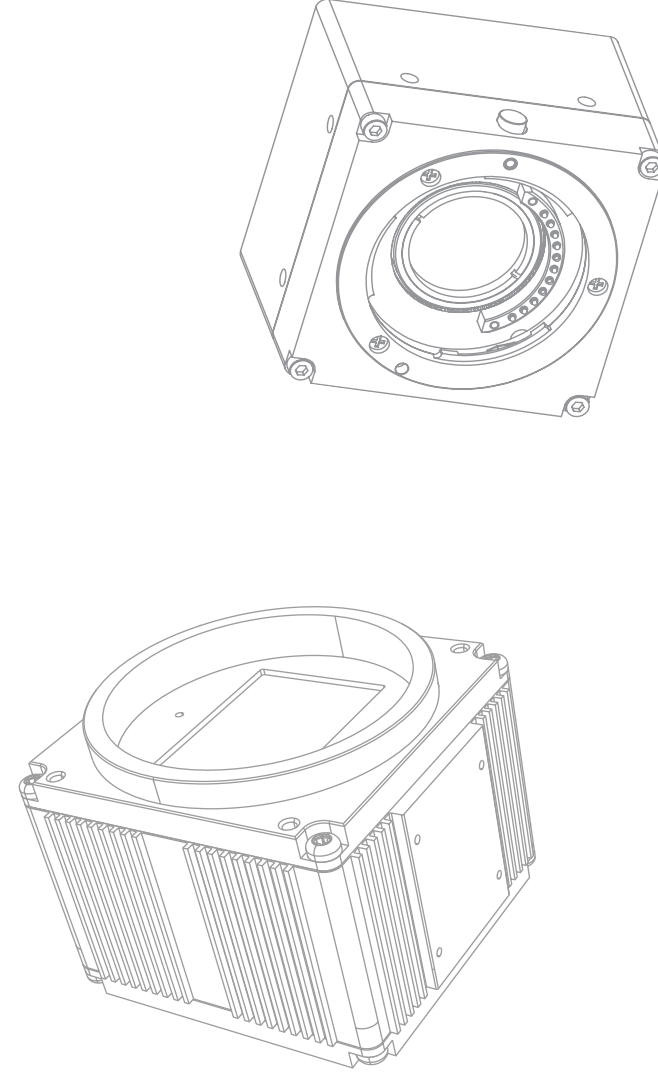
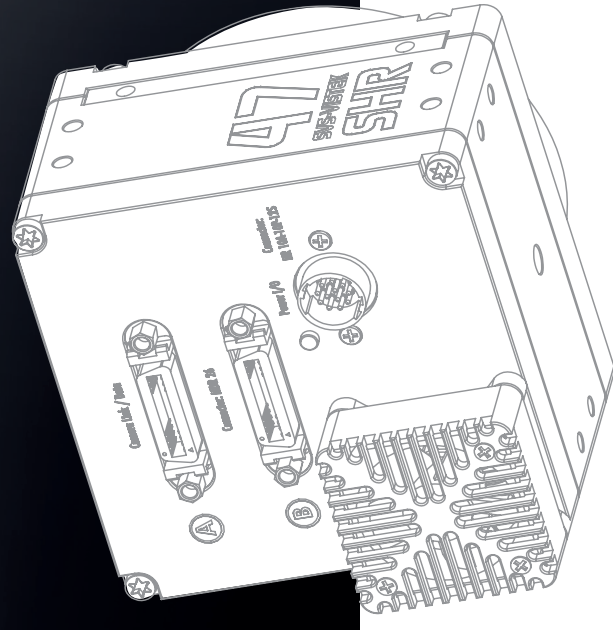

## Industrial Cameras

02/2017

Industrial Cameras  
SVCam-Product Line made by SVS-Vistek



### Design

- Flexible and scalable with identified connector pinout in all camera series
- Individual custom OEM designs for system integrators
- Industrial long-term support of cameras
- Wide power supply range 10 - 25 V

### Engineering and Production

- Excellent optical precision
- Precise and rugged long life mechanical design
- Advanced temperature management
- Industrial protection class up to IP67

### Unique Features

- PWM power drives for LED lights (LED)
- Programmable sequencer for shutter and LEDs (SEQ)
- Programmable I/O logic (PLC)
- Burst mode (BST)
- Safe trigger (STT)
- Dynamic lens control (MLT)

### Solid I/O Concept

- Home and industrial M12 connectors
- Configurable I/O matrix
- Up to 4 x power PWM OUT max. 3 A
- Up to 4 x trigger IN, TTL/24V
- Up to 2 x optical IN
- RS232 or RS422 IN/OUT

### Software

- Works with any GenICam camera
- Windows, Linux and macOS supported
- Compliant with standards like USB3 Vision, GenPress, GigE Vision, Camera Link
- GenICam transport layer for out-of-the-box compatibility to nearly all Machine Vision software like OB, HALCON, MVTec, openCV, Aivision, eyeVision, COGNEX VisionPro, Movidius, ML, LabView, VisionBuilder, Streamix, arBUS SDK and many others

USB3 VISION, MIK, CXP, PCOL, GENICAM, GENICAM

High-quality cameras, components and expertise from SVS-Vistek from reliable elements of your own application. We are committed to ensuring this and will be pleased to provide experts to support you during the entire design-in process.

Camera Concept  
by SVS-Vistek



### Supported Features and Technologies:

- Progressive Scan CCD sensors (VGA up to 47 MP)
- Global Shutter CMOS sensors
- CD sensors with advanced Tap Balancing (manual or automatic)
- Monochrome and Color Versions (Bayer Pattern)
- White balance for each version (one push, continuous or manual)
- programmable logic I/O functionality with timers
- User-definable AOI (Area of Interest)
- Selectable Date- and Frame- Rate
- Demarcation Modes for higher frame rates
- Flat Field Correction
- Shading Correction
- Defect Pixel Correction
- Adjustable Gain and Offset
- Auto-Exposure and Auto-Gain
- Image Flip on the FPGA
- Look-Up-Table for Digital Resolution Mapping
- Exposure controlled by Trigger, manually or automatically
- 8 or 12 Bit (14 Bit on the ADQ)
- Wide Range Power Conditions: 10 - 25 V DC
- Various Trigger (In-/Ex-/Free running) and Exposure Modes
- Programmable Sequence for Shutter and strobe
- Pulse-Width Strobe-Control
- Logical Trigger Functions
- Schmitt-Trigger (Debounce)
- Particle Image Velocimetry (PIV-Mode)
- Built-in LED Controllers
- Versatile I/O-Concept:
  - Configurable I/O-Matrix
  - up to 4 x Trigger Input
  - up to 4 x Power Output (open drain)
  - Differential RS422 and serial RS232 In- and Out-pair
- GigE or Dual GigE Interface
- Camera Link Interface
- USB3 Interface
- GenPress Interface
- GigE Vision and GenCam Standard Compliant
- Support for all Lens Mount Standards
- Micro-Four-Thirds Bayonet (MFT) Standard supported
- Prepared for Lens-Flit Unit
- Operating Temperature Range from -10°C to +45°C (ambient)
- SDK for Windows (32/64 Bit) and Linux available
- Intuitive Empirical User Interface
- Power over Camera Link (PoCL)
- Power over Ethernet (PoE) on request
- Power over GenPress (PoGCP)

### Industrial Connectivity:

Hirose for ECO, ECO2, EVO, HR (CL medium and GigE only)

| Color | Pin | Pin B045 |
|-------|-----|----------|
| WH/OG | 1   | 1        |
| OG    | 2   | 2        |
| WH/EN | 3   | 3        |
| BU    | 4   | 4        |
| WH/BU | 5   | 5        |
| GN    | 6   | 6        |
| WH/EN | 7   | 7        |
| BN    | 8   | 8        |

Hirose for EVO, HR (CL Deco, CXP), SHR Series

| Color | Pin | Pin B045            |
|-------|-----|---------------------|
| BN    | 1   | VH+ (10V to 25V DC) |
| BU    | 2   | VH- (GND)           |
| WH    | 3   | R0D (RS232)*        |
| GN    | 4   | T0D (RS232)*        |
| PK    | 5   | IN1 (0-24V)         |
| YE    | 6   | IN2 (0-24V)         |
| BK    | 7   | OUTT (open drain)   |
| GY    | 8   | OUT2 (open drain)   |
| RD    | 9   | IN3+                |
| VT    | 10  | IN3-                |
| RPK   | 11  | OUT3+               |
| RB    | 12  | OUT3-               |

Hirose 4 I/O for option ECO

| Color | Pin | Pin B045          |
|-------|-----|-------------------|
| BN    | 1   | VH+ (10-25V DC)   |
| BU    | 2   | VH- (GND)         |
| WH    | 3   | R0D (RS232)       |
| GN    | 4   | T0D (RS232)       |
| IN1   | 5   | IN1 (0-24V)       |
| IN2   | 6   | IN2 (0-24V)       |
| OUT1  | 7   | OUT1 (open drain) |
| OUT2  | 8   | OUT2 (open drain) |
| IN3+  | 9   | IN3+ (open In+)   |
| IN3-  | 10  | IN3- (open In-)   |
| OUT3  | 11  | OUT3 (open drain) |
| OUT4  | 12  | OUT4 (open drain) |

### Industrial Ethernet M12

| Color | Pin | Pin B045 |
|-------|-----|----------|
| WH/OG | 1   | 1        |
| OG    | 2   | 2        |
| WH/EN | 3   | 3        |
| BU    | 4   | 4        |
| WH/BU | 5   | 5        |
| GN    | 6   | 6        |
| WH/EN | 7   | 7        |
| BN    | 8   | 8        |

### Industrial M12 - I/O Connector

| Color | Pin | Pin B045            |
|-------|-----|---------------------|
| BN    | 1   | VH+ (10V to 25V DC) |
| BU    | 2   | VH- (GND)           |
| WH    | 3   | R0D (RS232)*        |
| GN    | 4   | T0D (RS232)*        |
| PK    | 5   | IN1 (0-24V)         |
| YE    | 6   | IN2 (0-24V)         |
| BK    | 7   | OUTT (open drain)   |
| GY    | 8   | OUT2 (open drain)   |
| RD    | 9   | IN3+                |
| VT    | 10  | IN3-                |
| RPK   | 11  | OUT3+               |
| RB    | 12  | OUT3-               |

For more information our sales team will be pleased to assist you with expert advice. Please contact us.

Germany  
**SVS-Vistek GmbH**  
Mühlbacherstr. 20  
82229 Seefeld  
Tel. +49 (0) 81 52 99 85 0  
Fax +49 (0) 81 52 99 85 79  
info@svsvistek.com  
www.svsvistek.de

Japan  
**SVS-Vistek K.K.**  
Yokohama  
Tel. +81 8070 331 689  
apac@svsvistek.com  
www.svsvistek.com

USA  
**SVS-Vistek Inc.**  
Tel. +49 81 52 99 85 0  
info-usa@svsvistek.com  
www.svsvistek.com

