

# STEP 1

Separate the body from the back shell.

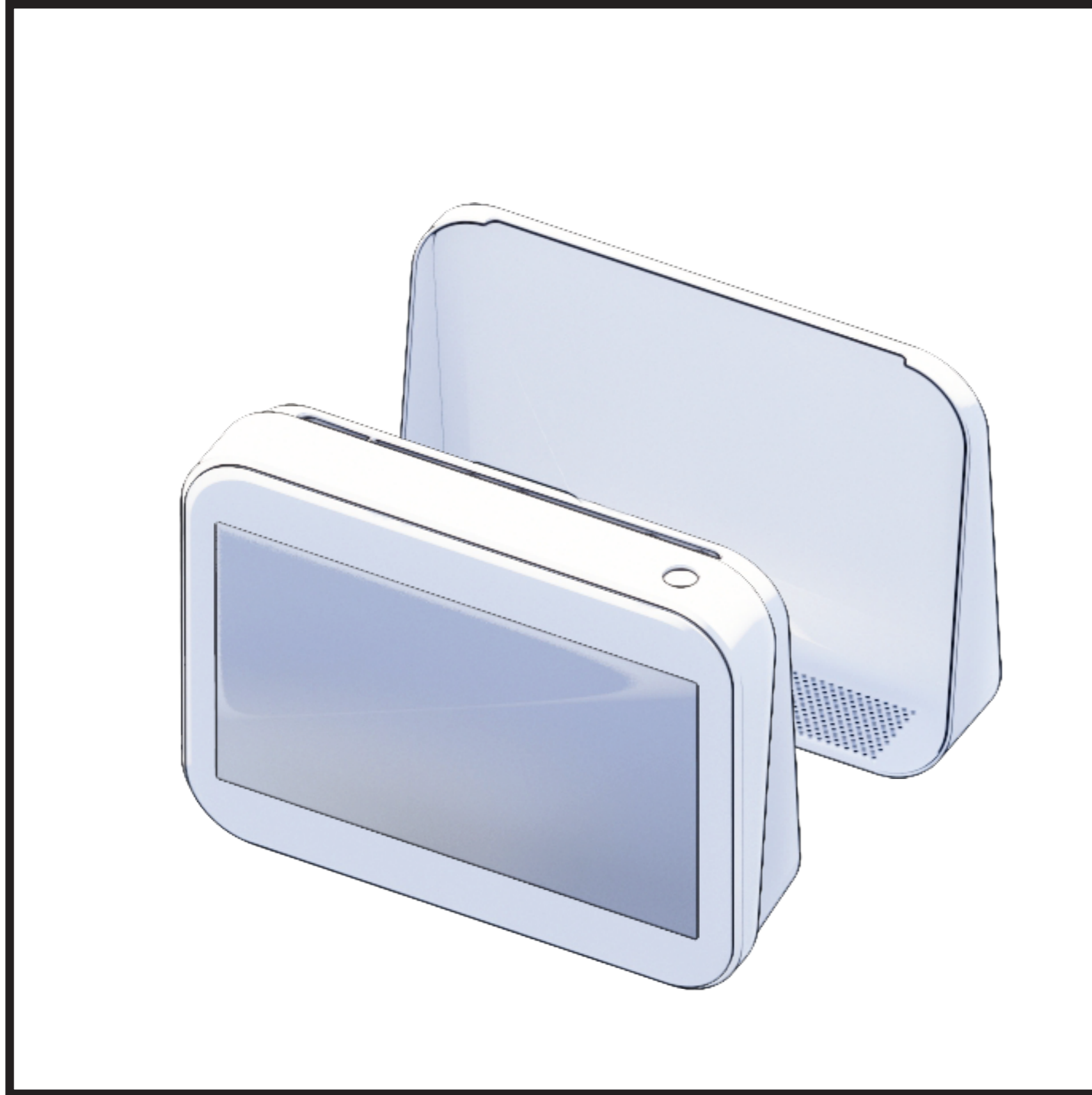

# STEP 2

Insert the modules securely.

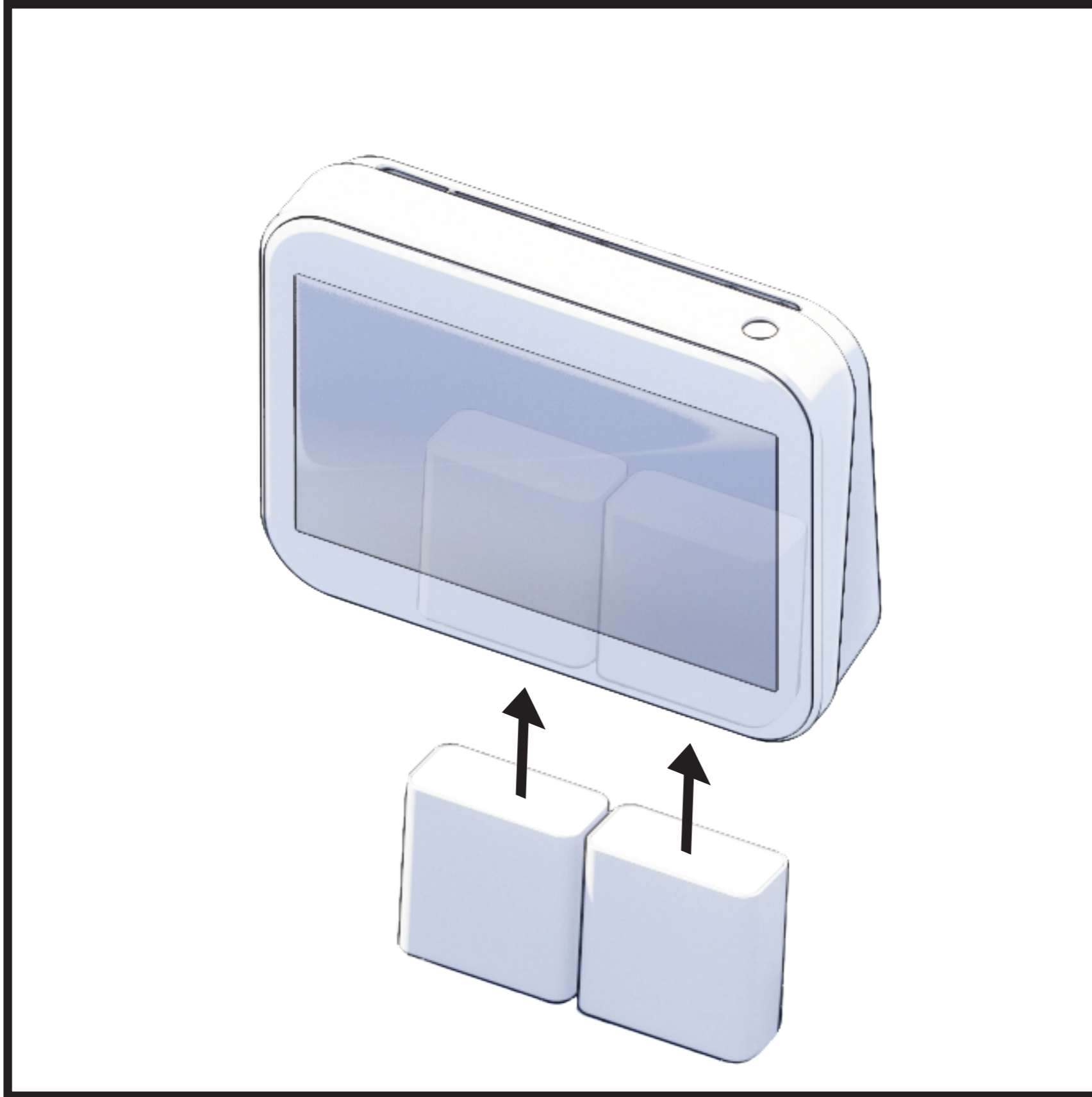

# STEP 3

Drill the holes and secure the back shell to the wall.

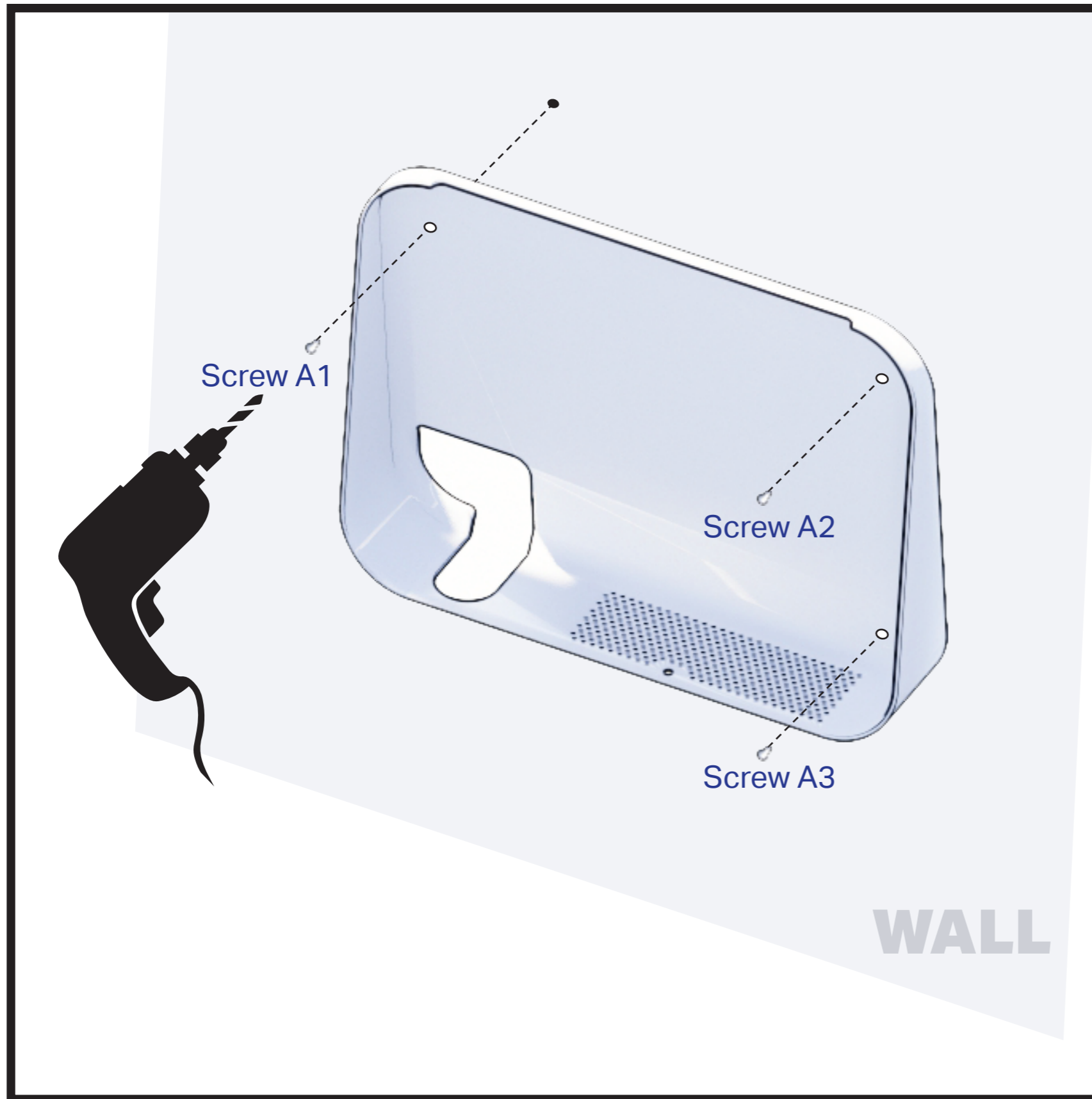

# STEP 4

Fit the product on the wall.

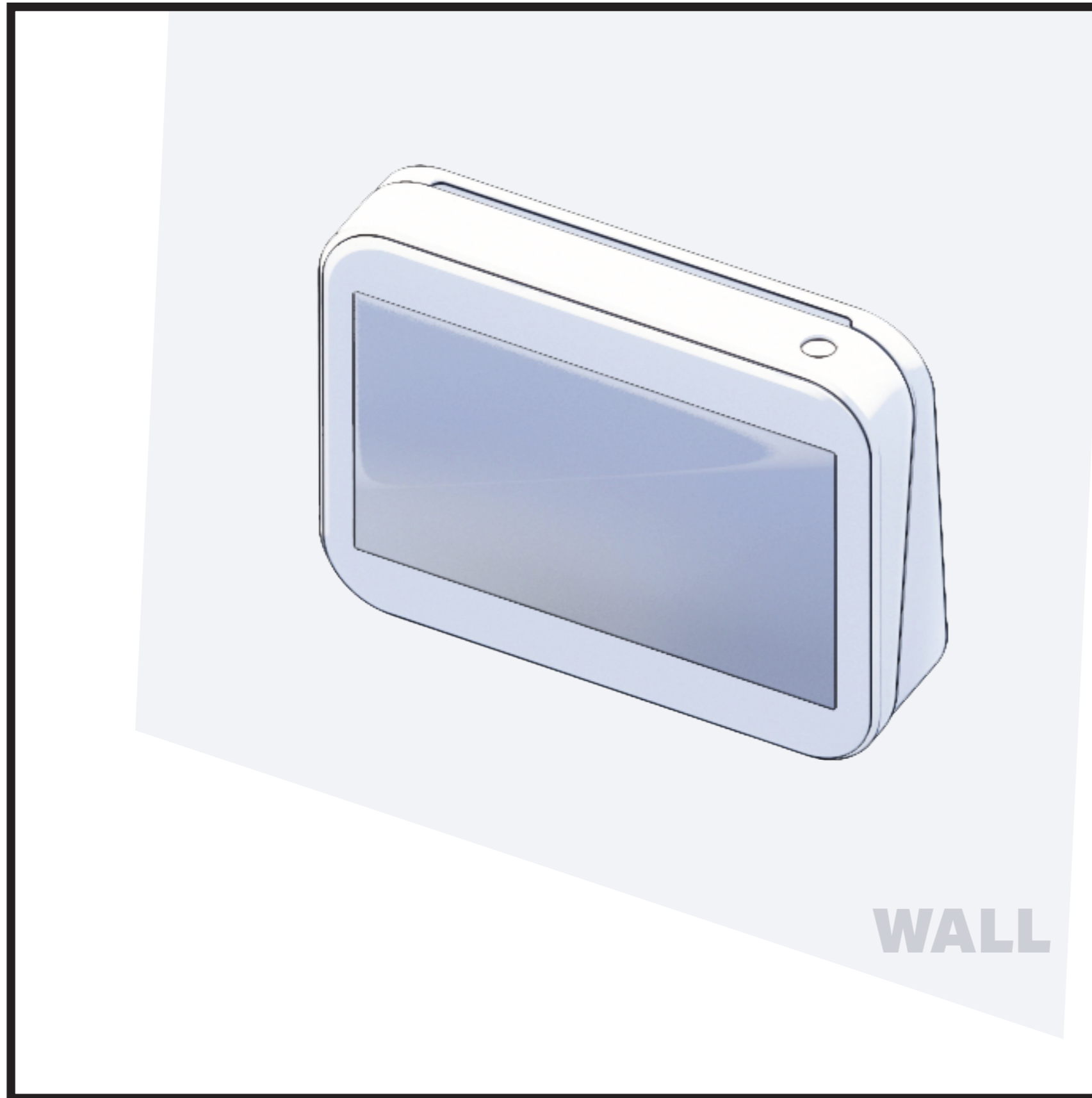

# STEP 5

Screw B to secure the unit to the back shell.

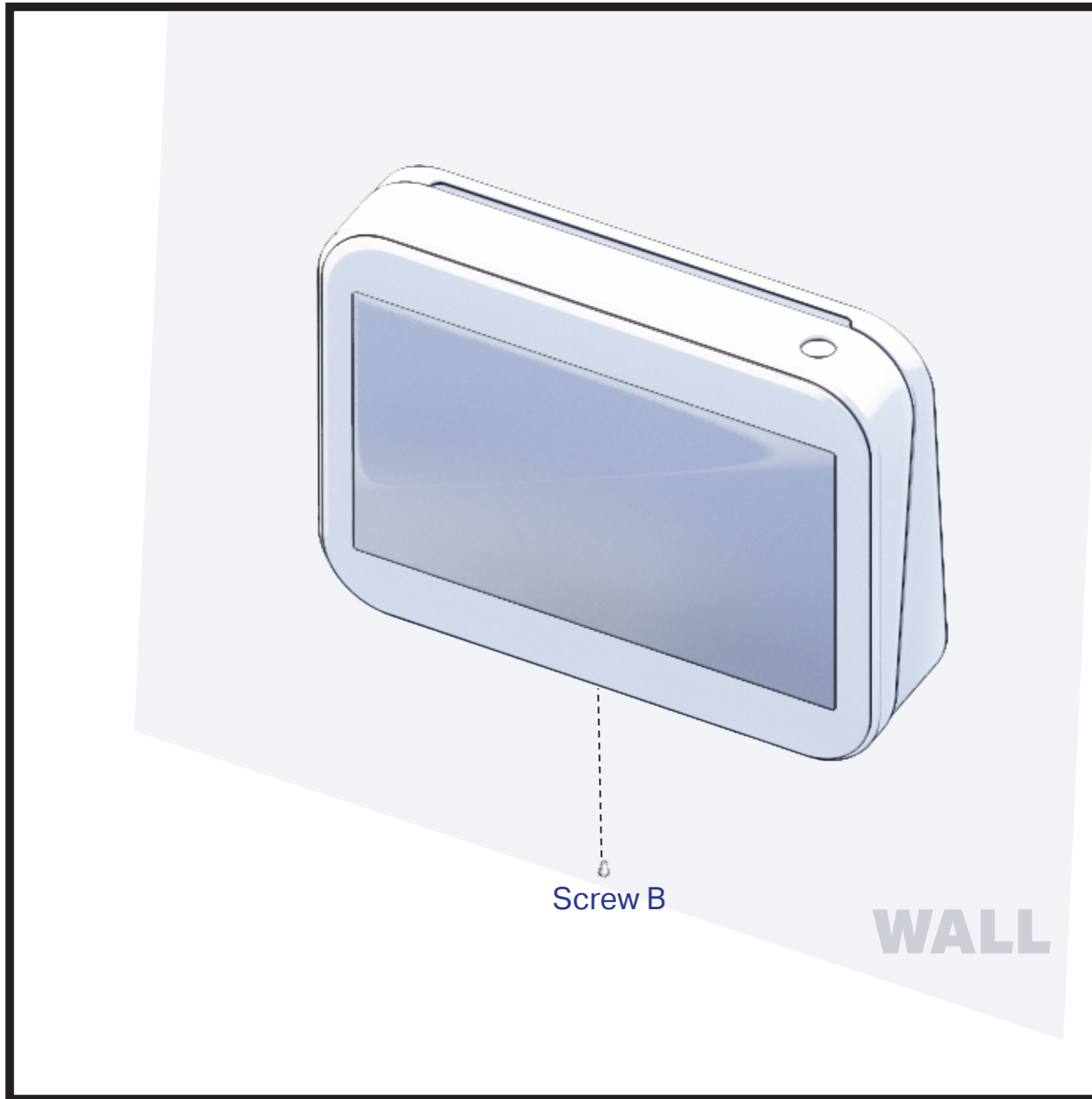

# STEP 6

Plug in the cable, turn on the power and test.

