

Poly Sheeting Quarantine Kit

The following quarantine/patient isolation room can be easily set up using components readily available from ZipWall & Syclone. The system works by having air exit the tent through the Sentry X4 which features a true HEPA filter, causing negative air pressure on the inside, which isolates the patient from the larger building.

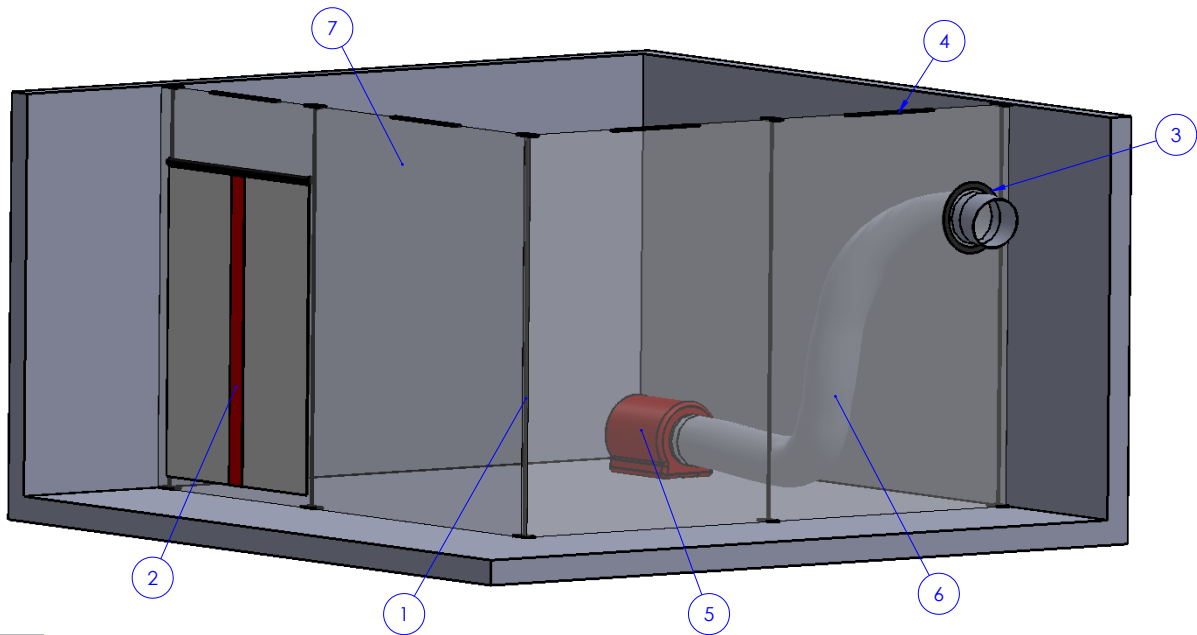

KEY

- ❶ A29607 ZipWall Dust Shield Barrier System, 6 Pack
- ❷ 1668-5378 ZipWall Magnetic Dust Barrier Door
- ❸ 2600-0125 ZipWall Pass-Through for Duct Hose
- ❹ 1696-7248 ZipWall Magstrip Dust Barrier Fastener (for drop ceiling applications)
- ❺ 1672-7671 Syclone Sentry X4 HEPA Air Scubber (Includes 99.97% @.03 micron air filter)
- ❻ 55208 12" Diameter Flexible Reusable Ducting
- ❼ 55603 Poly sheeting for Walls or Drop Ceiling Applications
(not shown) Polyken Teal Duct Tape (For sealing and installing the poly sheeting)

ZIPWALL DUST SHIELD BARRIER SYSTEMS



- Quick & easy set up
- Works in positive and negative air
- Tethers keep heads and plates together
- GripDisks™ prevent sliding on smooth floors

Item	Description
A29607	ZipWall SLP6 12' Dust Shield Barrier System, 6-Poles (ea)

ZIPWALL MAGNETIC DUST BARRIER DOOR KIT



- Adjustable header bar
- Magnetic strips create a continuous seal around the edge of the door
- High-tech fabric panel features a clear plastic window
- Sewn-in, self-closing magnets
- Can be used with positive or negative air

Includes: 7' 2" x 4' 7" door panel (1), magnetic strips (6), header bar (1), and a carry bag.



Item	Description
1668-5378	ZipWall MDK Magnetic Dust Barrier Door Kit (ea)

ZIPWALL FLEXIBLE REUSABLE DUCT ZPT DUST BARRIER PASS THROUGH™ ZIPWALL

Resealable opening for passing a duct hose up to 14" in diameter through a ZipWall® barrier. Mounts onto any ZipWall® pole and supports the weight of any hose while maintaining the integrity of the barrier. A nylon fabric sleeve seals around the hose with a quick cinch. When the hose is removed, the sleeve can be cinched closed to completely seal the opening. Pole and hose are not included.



Item	Description
2600-0125	Zipwall ZPT Passthrough For Duct Hose Up To 12" Diameter (ea)

ZIPWALL MAGSTRIP DUST BARRIER FASTENERS ZIPWALL

For keeping barrier tight between poles when working with a drop-ceiling. Powerful magnetic strips easily attach to drop-ceiling steel grid, using a pole and the specially designed applicator. No ladders or tape required. A quick and safe tool for keeping a barrier tight between poles. Four 26" magnetic strips and one applicator. Pole not included.



Item	Description
1696-7248	Zipwall MS4 Magstrip Dust Barrier Fasteners (pk)

SYCLONE SENTRY X4 HEPA AIR SCRUBBER SYCLONE

High-efficiency air filtration in a highly portable unit. Designed with advanced 2-stage filtration technology. Daisy-chain capable, and you can link up to five units on one power outlet. Also stackable, lightweight and easily transportable.

- Healthcare, hospitals, etc.
- Clean Rooms
- Dust
- External Ducting
- Air Scrubbing
- Ventilation
- True HEPA 99.97%@0.3 micron



Item	Description
1672-7671	Syclone Sentry X4 Red HEPA 400CFM Negative Air and Air Scrubber Machine with Filters (ea)
1682-7077	Syclone Sentry X4 Blue HEPA 400CFM Negative Air and Air Scrubber Machine with Filters (ea)

FLEXIBLE REUSABLE DUCT

Strong, durable, and flexible reusable ducting. Design allows for easy routing of ventilation. Great for removing excess heat when combined with an exhaust fan.



Item	Description
55028	Flexible Reusable Duct, 12" x 25" (ea)

POLY SHEETING

Heavy-duty polyethylene sheeting used for constructing containment.

- Available from 4 mil to 6 mil thickness
- Available in fire retardant



Item	Description
56063	Poly Sheeting, Clear 6 mil, 20' x 100' (roll)

POLYKEN TEAL DUCT TAPE

Heavy-duty 10 mil duct tape for hanging and sealing plastic sheeting and waste disposal bags. Adheres well to a wide variety of surfaces. Will not twist or curl during application and is highly visible for critical work. 2" width for excellent coverage.



Item	Description
A12408	Polyken 244 Teal Duct Tape, 2" x 60 yds., 10 mil (24/case)

X-GUARD FIRE RESISTANT RIDGED PANELS

Made of polymers and polypropylene, this corrugated material is widely recognized and used in the health care construction industry across the country. Perfect for floor-, wall-, counter-top protection and temporary door and window replacement.

- Fire, impact, and water resistant
- Strong & durable
- Lightweight
- Hygienic
- Cost effective
- Reusable
- 100% recyclable
- Easy to convert

Applications include: Health Care, Restoration, Abatement, Construction, Drywall, Painting, Tuck Pointing, Hard Containment, Long-term Use, Temporary Use.

Item	Description
1656-6111	White Fire Resistant Panels, 48" x 96" x 4mm (ea)



Custom Kits Available **EDGE GUARD**

Edge Guard offers lightweight, modular panels with adjustable height, ranging from 7'8" to 10'. They also come in 6", 12", 24", 36", and 48" wide variants; can be assembled quickly without the use of tools and can be cleaned with ease. You may opt for different porting options so you can attach 8" and 10" diameter high-efficiency particulate air exhaust fans.

Contact your account representative for details



SAMPLE IMAGES