



INTERIOR PROTECTION FOR CARGO VEHICLES

LEGEND FLEET SOLUTIONS

PRODUCT GUIDE 2017

MERCEDES

/ Safety

/ Innovation

/ Ergonomics



Legend Fleet Solutions' dealer network includes 256 registered dealers, 52 of which are stocking distributors. Legend has dealers servicing all Canadian Provinces, and 48 US States. Legend offers flexible dealer opportunities to accommodate fleet customers wherever they are planning their fleet vehicle upfits.

EXPERTS IN FLEET PROTECTION.

AS THE PREMIER SOLUTION FOR FLEET VEHICLE CARGO-SPACE WALL LINERS, RUBBER MATS AND RIGID FLOORING, WE OFFER THE LIGHTEST, MOST DURABLE AND FASTEST TO INSTALL CUSTOM FIT SOLUTIONS IN THE INDUSTRY, THAT SAVES YOU TIME, FUEL COSTS AND PRESERVE THE VALUE OF YOUR FLEET. TO TOP IT OFF, OUR PRODUCTS DRAMATICALLY IMPROVE THE SAFETY OF YOUR EMPLOYEES AND HELP YOUR CARGO STAY PUT WHILE UNDER WAY.



MERCEDES MEASUREMENTS

METRIS

SPRINTER 144 WB LR

SPRINTER 144 WB HR

SPRINTER 170 WB

SPRINTER 170 EXT WB

METRIS

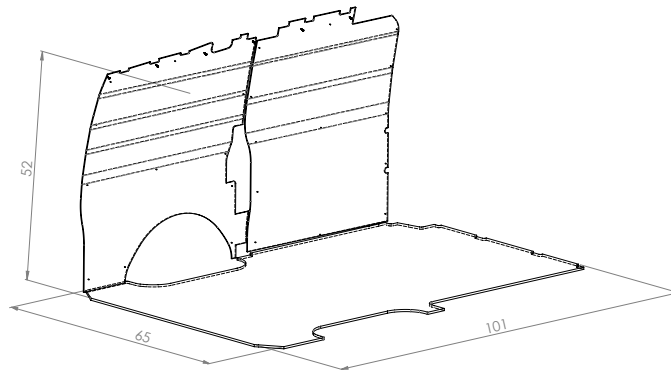

SPRINTER 144 WB LR

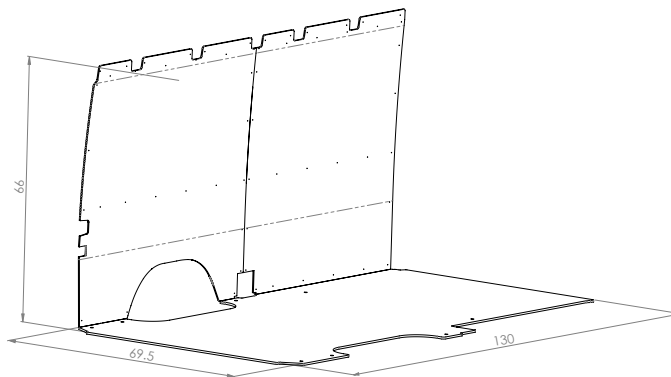

MERCEDES MEASUREMENTS

SPRINTER 144 WB HR

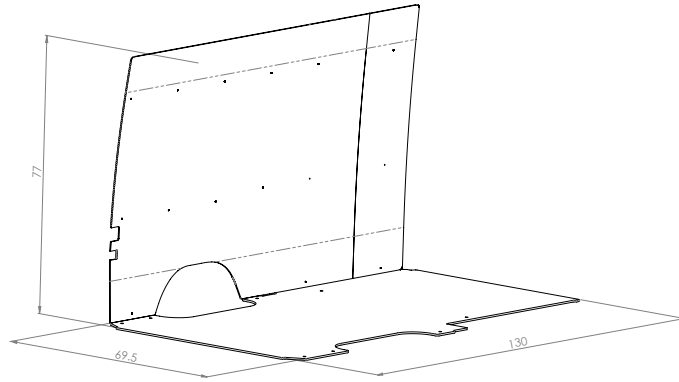

6

SPRINTER 170 WB

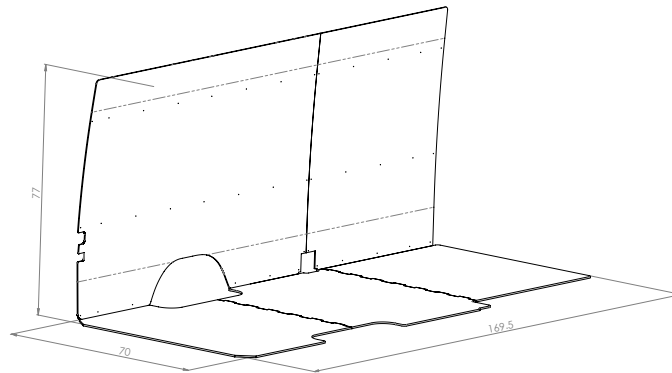

SPRINTER 170 EXT WB

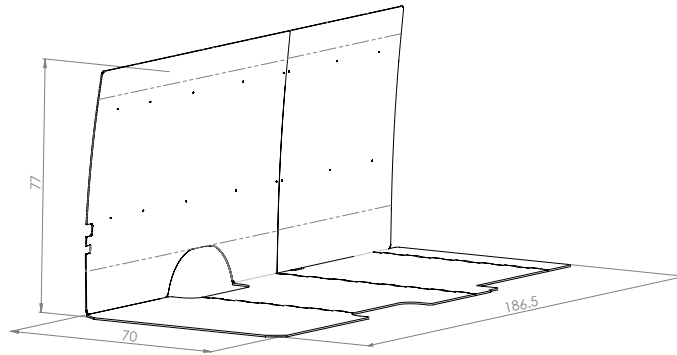

THE PRODUCTS

RIGID FLOORING

RUBBER MATS

VFS SYSTEM

LINERS

SILL PLATES

RIGID FLOORING

HD ULTRAGRIP

- Rigid HDPE plastic floor for durability
- Unique rubberized surface for safety
- Maintenance free
- Meets FMVSS 302

Additional Codes

- .1 - dual wheels
- .2 - dual side doors

PART NUMBERS

152-162-6441	Metris 126 WB - 2 pc
152-162-6641	Metris 126 WB - 1 pc
122-162-6441	Sprinter 144 WB - 3 Pc
122-162-6641	Sprinter 144 WB - 2 Pc
132-162-6441	Sprinter 170 WB - 3 Pc
132-162-6641	Sprinter 170 WB - 2 Pc
142-162-6441	Sprinter 170 Ext. WB - 4 Pc
142-162-6641	Sprinter 170 Ext. WB - 2 Pc

RIGID FLOORING

10

STABILIGRIP

NEW dimensionally-stable floor with improved durability and strength. Built with the toughest proprietary blend of recycled products, its versatility can be used in a wide variety of applications.

Additional Codes

.1 - dual wheels

.2 - dual side doors

PART NUMBERS

152-135-6441	Metris 126 WB - 2 pc
122-135-6441	Sprinter 144 WB - 3 Pc
132-135-6441	Sprinter 170 WB - 3 Pc
142-135-6441	Sprinter 170 Ext. WB - 4 Pc

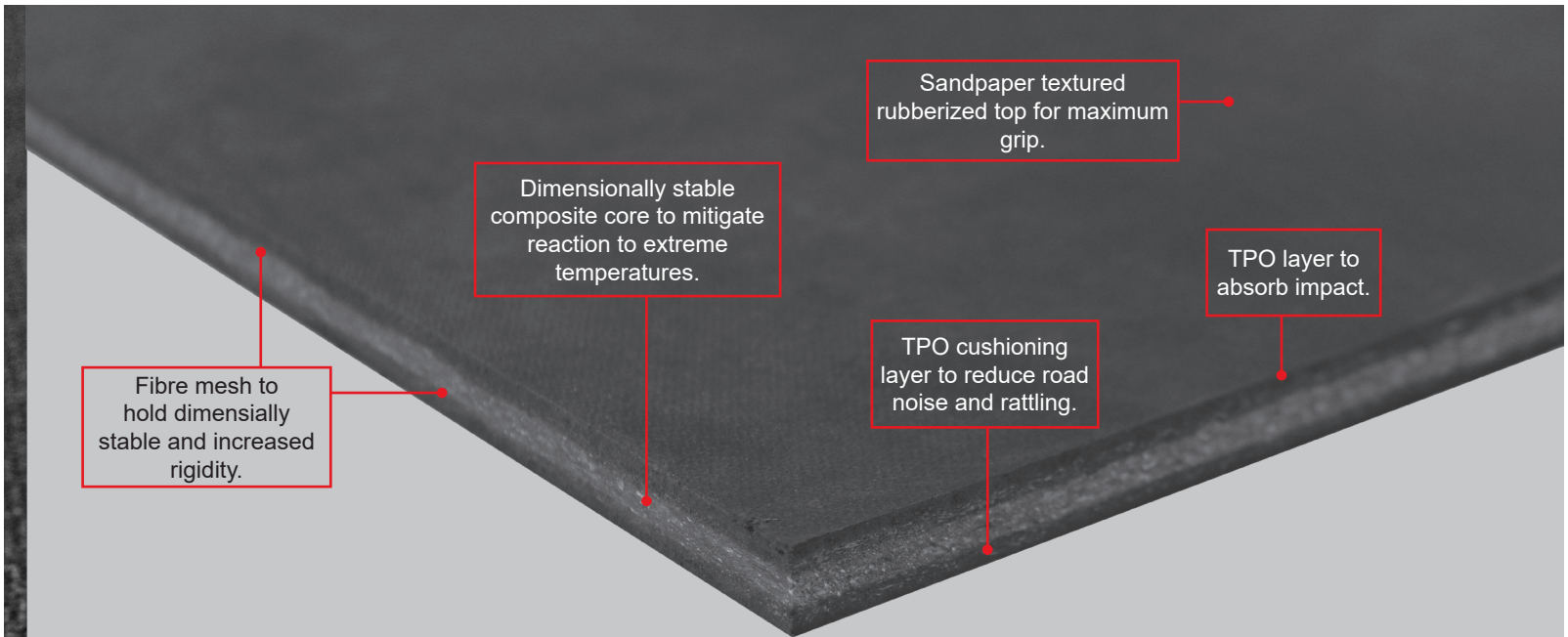

Fibre mesh to hold dimensionally stable and increased rigidity.

Dimensionally stable composite core to mitigate reaction to extreme temperatures.

Sandpaper textured rubberized top for maximum grip.

TPO cushioning layer to reduce road noise and rattling.

TPO layer to absorb impact.

WHY STABILIGRIP?

- **Efficient** - flat, durable, and safe; making it easy for technicians to work on.
- **Safety** - minimizes slip hazards and chances of shifting cargo.
- **Dimensionally-stable** - will not swell or bubble even in extreme temperatures.
- Impact and puncture resistant – protects floor of van from damage
- Custom fit to each specific vehicle
- Professional looking and clean-easy
- Decreases road noise.
- Non-porous plastic – resists stains and mold
- Fine texture gives grip but allows forklift freight loading
- Economical

RIGID FLOORING

12

HD ULTRAFLOOR

- Heavy duty protection
- Non-porous plastic – resists stains and mold
- Fine texture gives grip but allows forklift loading of freight
- Economical

Additional Codes

.1 - dual wheels

.2 - dual side doors

PART NUMBERS

152-061-6441	Metris 126 WB - 2 pc
152-061-6641	Metris 126 WB - 1 pc
122-061-6441	Sprinter 144 WB - 3 Pc
122-061-6641	Sprinter 144 WB - 2 Pc
132-061-6441	Sprinter 170 WB - 3 Pc
132-061-6641	Sprinter 170 WB - 2 Pc
142-061-6441	Sprinter 170 Ext. WB - 4 Pc
142-061-6641	Sprinter 170 Ext. WB - 2 Pc

KK-PLUS

- 11 ply birch plywood; extremely rigid
- Wear resistant phenolic resin coating
- Textured surface for traction and safety
- Very stable-low expansion and contraction

Additional Codes

- .1 - dual wheels
- .2 - dual side doors

PART NUMBERS

152-112-4442	Metris 126 WB - 2 pc
152-112-4542	Metris 126 WB - 1 pc
122-112-4442	Sprinter 144 WB - 3 Pc
122-112-4642	Sprinter 144 WB - 2 Pc
132-112-4442	Sprinter 170 WB - 3 Pc
132-112-4642	Sprinter 170 WB - 2 Pc
142-4442	Sprinter 170 Ext. WB - 4 Pc
142-112-4642	Sprinter 170 Ext. WB - 2 Pc

RUBBER MATS

14

AUTOMAT - BAR

- Incredible traction
- One piece mat; no joints
- Heavy duty

Additional Codes

.1 - dual wheels

.2 - dual side doors

PART NUMBERS

152-043-7321	Metris 126 WB - 1 pc
122-043-7321	Sprinter 144 WB - 1 Pc
132-043-7021	Sprinter 170 WB STD- 1 Pc
142-043-7021	Sprinter 170 Ext. WB - 1 Pc

RUBBER MATS

15

ARMORMAT

- Toughest mat on the market
- Suitable for wet or oily applications
- Tread plate finish for aggressive traction

Additional Codes

- .1 - dual wheels
- .2 - dual side doors

PART NUMBERS

152-111-7521	Metris 126 WB - 2 pc
122-111-7521	Sprinter 144 WB - 3 Pc
132-111-7521	Sprinter 170 WB - 3 Pc
142-111-7521	Sprinter 170 Ext. WB - 4 Pc

ALL NEW VAN FLOORING SYSTEM

16

LEGEND VFS

PART NUMBERS

152-045-0040	Metris 126 WB
122-045-0040	Sprinter 144 WB
132-045-0040	Sprinter 170 WB
142-045-0040	Sprinter 170 Ext. WB

Additional Codes

- .1 - dual wheels
- .2 - dual side doors



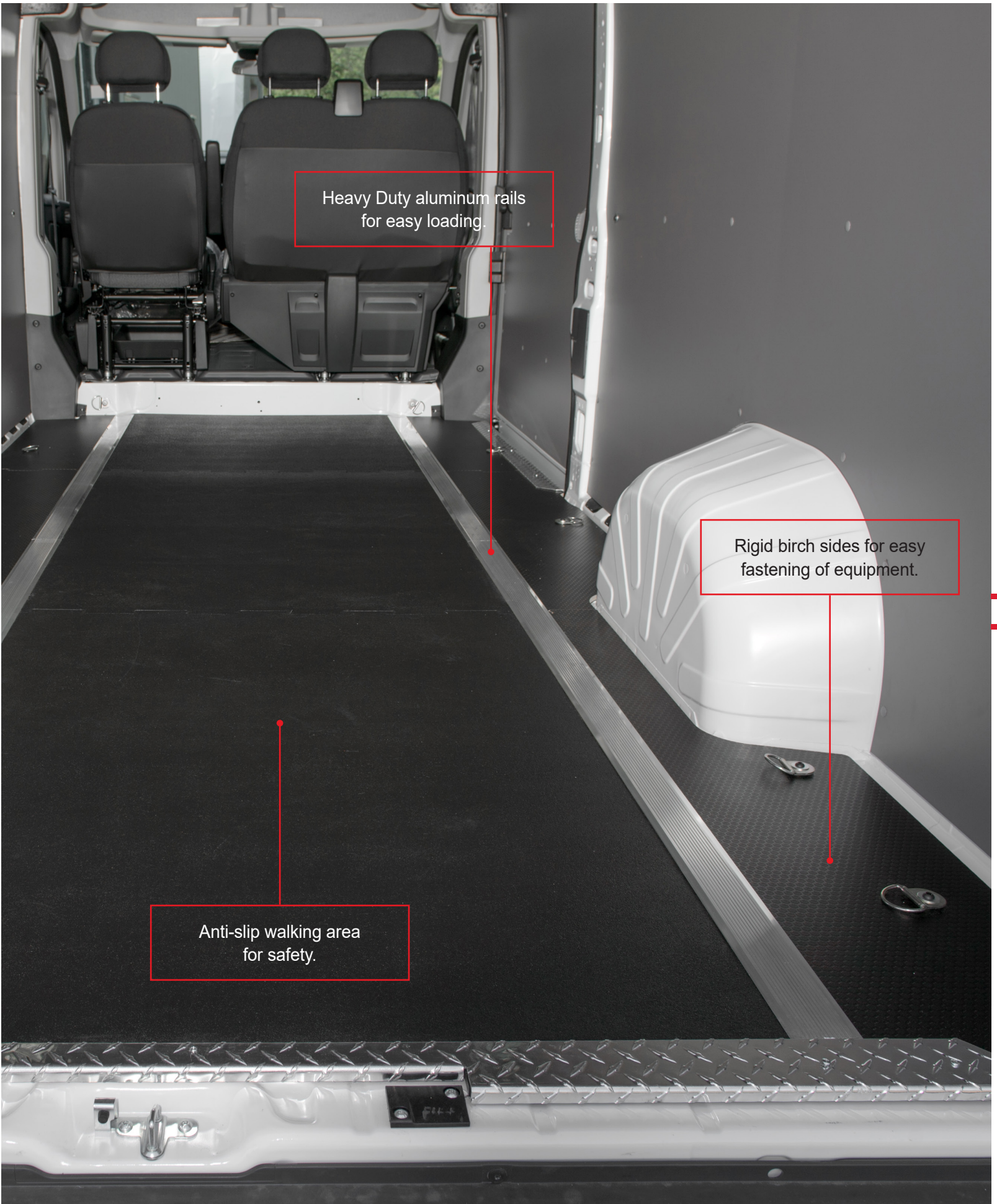

Heavy Duty aluminum rails
for easy loading.

Rigid birch sides for easy
fastening of equipment.

Anti-slip walking area
for safety.

The image shows the interior of a white van with a metal shelving unit installed. The shelving unit is made of perforated metal and has several shelves. The van's interior is white, and the floor is black. The van door is open, and the exterior is visible on the left side. The sky is blue with some clouds. The text is overlaid on a dark grey rectangular background in the lower-left corner of the image.

“THE DIFFERENCE IN MY VEHICLES WITH AND WITHOUT LEGEND PRODUCTS IS NIGHT AND DAY. THE RIDE IS QUIETER, THE TEMPERATURE IS MODERATED, THE VEHICLE IS PROTECTED, AND IT FINISHES THE VEHICLE WITH A CLEAN PROFESSIONAL LOOK. I RECOMMEND LEGEND PRODUCTS TO EVERY SINGLE ONE OF MY CLIENTS, AND WILL CONTINUE TO DO SO.”



WALL LINERS

20

DURATHERM

- Interior protection
- Sound deadening
- Light weight
- Thermal barrier
- Precision cut
- Easy install
- Available in white and grey

Additional Codes

.LR - Low Roof

.HR - High Roof

.2 - Dual Side Doors

PART NUMBERS

154-114-2613	Metris 126 WB - Grey
154-114-2614	Metris 126 WB - White
124-114-2613.LR	Sprinter 144 WB - Grey - low roof
124-114-2614.LR	Sprinter 144 WB - White - low roof
124-114-2613.HR	Sprinter 144 WB - Grey - high roof
124-114-2614.HR	Sprinter 144 WB - White - high roof
134-114-2613	Sprinter 170 WB - grey
134-114-2614	Sprinter 170 WB - White
144-114-2613	Sprinter 170 Ext. WB - Grey
144-114-2614	sprinter 170 Ext. WB - White

CEILING LINERS

21

CEILING LINER

- Fully Molded wall panel
- 3/16 Durable, scratch resistant plastic
- Increases resale value

Additional Codes

- .LR - Low Roof
- .HR - High Roof
- .3 - Side Barn Doors

PART NUMBERS

155-114-2613	Metris 126 WB - Grey
155-114-2614	Metris 126 WB - White
125-114-2613.LR	Sprinter 144 WB - Grey - low roof
125-114-2614.LR	Sprinter 144 WB - White - low roof
125-114-2613.HR	Sprinter 144 WB - Grey - high roof
125-114-2614.HR	Sprinter 144 WB - White - high roof
135-114-2613	Sprinter 170 WB - grey
135-114-2614	Sprinter 170 WB - White
145-114-2613	Sprinter 170 Ext. WB - Grey
145-114-2614	Sprinter 170 Ext. WB - White

DOOR LINERS

22



DOOR LINER

- Fully Molded wall panel
- 3/16 Durable, scratch resistant plastic
- Increases resale value

Additional Codes

.LR - Low Roof

.HR - High Roof

.2 - Dual Side Doors

PART NUMBERS

153-114-2613	Metris 126 WB - Grey
153-114-2614	Metris 126 WB - White
103-114-2613.LR	Sprinter - Grey - low roof
103-114-2614.LR	Sprinter - White - low roof
103-114-2613.HR	Sprinter - Grey - high roof
103-114-2614.HR	Sprinter - White - high roof



SILL PLATES

23

TOP SILL

- Neat transition between wall liner and ceiling liner
- Precut formed aluminum for strength
- Light weight

SILL PLATES

24

SILL PLATES

- Side and rear sill plates
- Aluminum checker plate for high grip/high wear
- Custom cut and formed edge protection
- Professional finish

PART NUMBERS

156-151-1010	Metris 126 WB - Side Sill
158-151-1010	Metris 126 WB - Rear Sill
106-151-1010	Sprinter - Side Sill
108-151-1010	Sprinter - Rear Sill





EXPERTS IN FLEET PROTECTION

56957 Hwy 3 West,
Tillsonburg,
ON N4G 4G8

Phone: 519.688.1043
Toll Free: 866.223.2256
Fax: 519.842.7724
info@legendfleet.com

