

STOWED VIEW

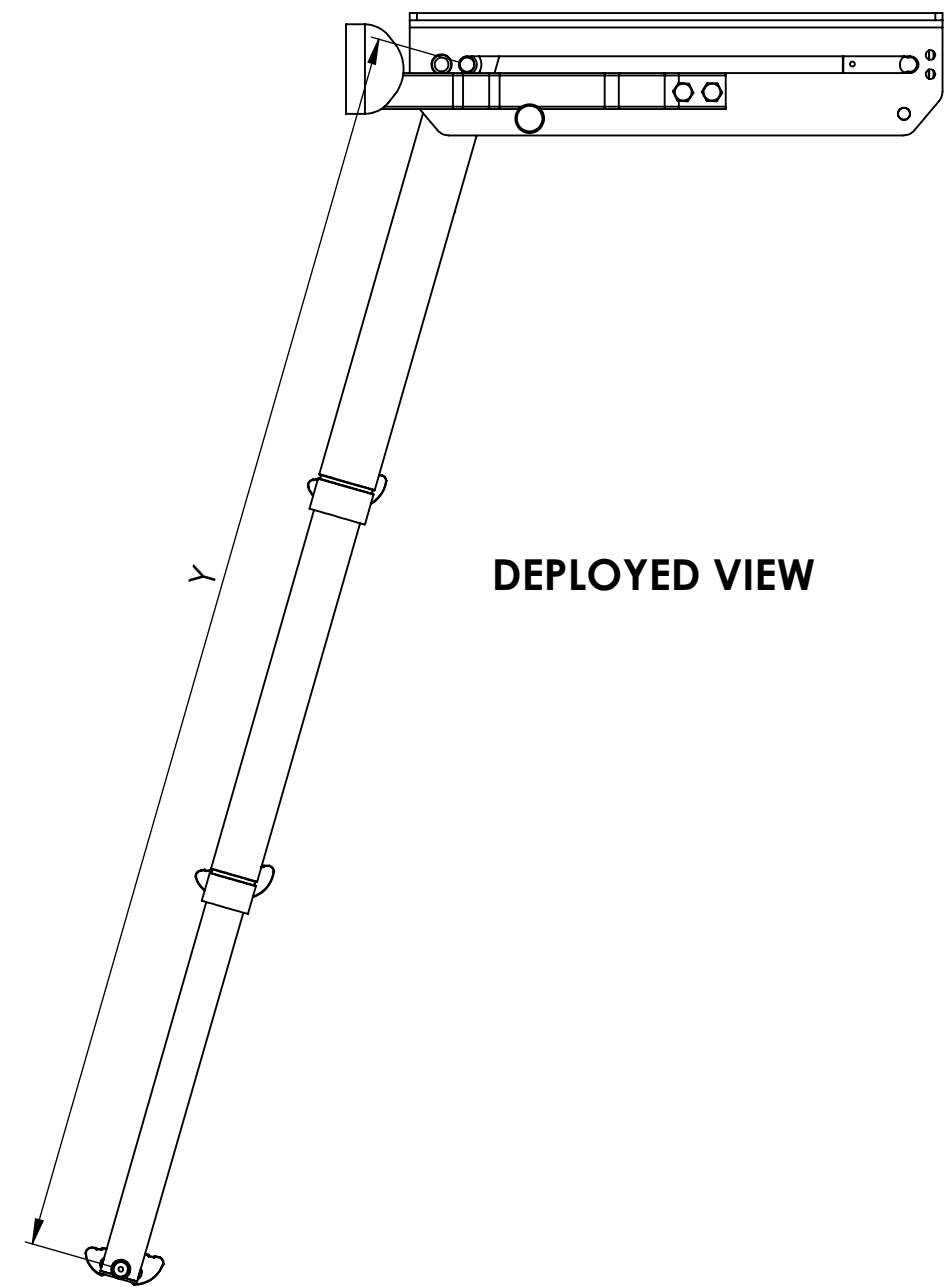

DEPLOYED VIEW

| PART # | H | W | X | Y |
|----------|--------|--------|--------|-------|
| L6T53200 | 18.875 | 17.250 | 15.000 | 32.64 |
| L6T43200 | 14.625 | 15.625 | 10.750 | 32.64 |
| L6T23200 | 10.625 | 11.625 | 6.750 | 32.64 |

| | | | | | |
|--|--|--------------|------------------|---|--|
| UNLESS OTHERWISE SPECIFIED: | | DATE: | 5-20-19 | GG Schmitt & Sons | |
| DIMENSIONS ARE IN INCHES TOLERANCES: FRACTIONAL ± 1/64" ANGULAR: MACH ± 1/2 Deg. BEND ± 1 Deg. TWO PLACE DECIMAL ± .03" THREE PLACE DECIMAL ± .015" | | DRAWN BY: | <i>Al Bender</i> | | |
| DO NOT SCALE THIS DRAWING | | APPROVED BY: | | SIZE B DWG. NO. WS-L6T43200 ORIG.NO. SAME SHEET 1 OF 1 | |
| MATERIAL: T-304 Stainless Steel | | SCALE: | N/A | | |
| FINISH: Full Mirror Polish except where Noted | | | | | |