

MOBIUS



TECHNICAL SPECIFICATIONS

 **MOBIUS**
TRIMMER

MOBIUSTRIMMER.COM

DESIGNED AND BUILT
for
COMMERCIAL SCALE CULTIVATORS

SPECIFICATIONS & REQUIREMENTS SUMMARY

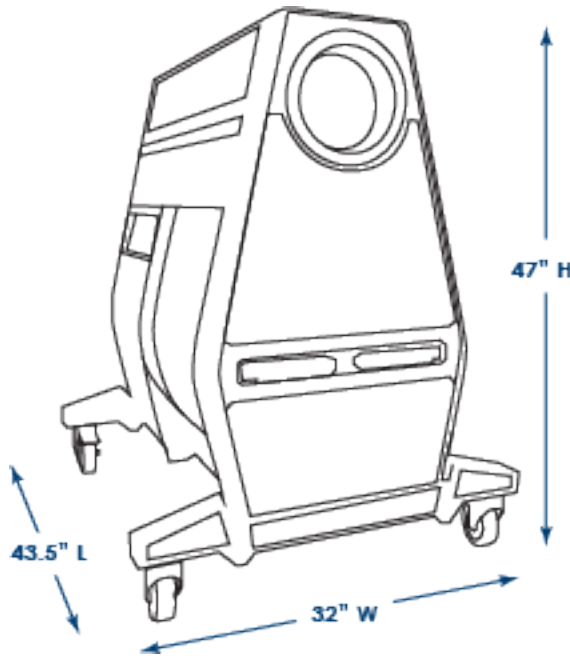

DIMENSIONS

Total width is 43" with Trim Tote in place.

Total length is 77.5" with input and output shrouds in place.

WEIGHT

462 lbs

ELECTRICAL REQUIREMENTS

SINGLE PHASE: 240v, 30amps

THREE PHASE: 208v, 22amps

POWER

VACUUM MOTOR: 5HP

CUTTER MOTOR: 0.75HP

TUMBLER MOTOR: 1/8HP

OUTPUT

WET FEED RATE:

- 66 - 120 lbs/hr
- 30 - 55 kg/hr

DRY FEED RATE:

- 22 - 44 lbs/hr
- 10 - 20 kg/hr

ASSEMBLY DIMENSIONS

COMPONENT	DIMENSIONS	WEIGHT
Mobius <i>without</i> Input Hopper, Output Chute or Trim Tote in place*	43.5" L x 32" W x 47" H*	391 lbs.
Mobius <i>with</i> Input Hopper, Output Chute and Trim Tote in place	77.5" L x 43" W x 46.5" H	458 lbs.
Body Assembly only	43.5" L x 32" W x 36.75" H	284.3 lbs.
Lid Assembly (includes tumbler, brush, lid screens and polycarbonate cap)	42" L x 14.75" W x 11.75" H	51 lbs.

For set up with conveyors, with no tilt angle on the machine:

Height to bottom of tumbler opening	34 ^{1/8} "
Height to centre of tumbler opening	37 ^{3/4} "

* Note, the M108 will fit through a standard 32" door opening

NOISE RATINGS

COMPONENT	OPERATING RANGE	RATING
Vacuum	1 – 11	77 – 92 decibels
Blades	1 – 11	82 – 88 decibels
Tumbler	1 – 11	70 – 72 decibels
Full Machine	All systems at minimum	82 decibels
Full Machine	All systems at maximum	93 decibels

COMPONENT DIMENSIONS & WEIGHTS

COMPONENT	DIMENSIONS*	WEIGHT
Tumbler	42.25" L x 8.25" Diam.	2.5 lbs.
Input Hopper	18" L x 16" W x 14.75" H	4 lbs.
Output Chute	18" L x 16" W x 15" H	4 lbs.
Brush	36" L x 2.5" Diam.	2.7 lbs.
Trim Tote	13 USG / 49.2 L	4 lbs.
Helical Blades	37.25" L x 2.25" Diam	15 lbs. x 3 blades
Bedknife Assembly	35.25" L x 1.75" W x 1.5" H	2.7 lbs. x 3 knives
Retainer Assembly	35.25" L x 1.75" W x 1.5" H	2.6 lbs. x 3 retainers
Impeller Housing	38.25" L x 6.25" W x 22.75" H	19 lbs.
Separator Housing	38.25" L x 14.5" W x 22.75" H	34 lbs.
Exhaust Air Filter	15.5" L x 6" W x 19" H	0.8 lbs.

* Note that, as most parts are asymmetrical, minimum packing dimensions have been provided.

TUMBLER TILT RANGE



AUTOMATIC TUMBLER TILT	RANGE
Angle	0° – 6.5°

MATERIALS AND TREATMENTS

The following is a list of the primary materials and treatments used in the manufacture of the Mobius Trimmer M108. Note that all plant-touching materials and parts are listed.

PART(S)	MATERIAL & TREATMENT
Helical Blades	4140 Alloy Steel, nitrided
Bed Knives	UHB SS716 Stainless Steel, EA E-30CL Adhesive
Screens	3003-H14 Aluminum, anodized
Aluminum Extrusion Parts	6063-T6 Aluminum, anodized
Aluminum Flat Plates & Sheet Metal Parts	5052 Aluminum Sheet Metal
Tumbler Body	316 Stainless Steel Wire
Lid Assembly and Trim Tote Transparent Shields	Hardened & Coated Polycarbonate (Lexan™ MR10)
Tumbler End Caps - Versions A, B, C and D	ABS (Acrylonitrile-Butadiene-Styrene) Plastic
Tumbler End Caps - Versions E and later	Tritan™ Copolyester TX1501HF
Tumbler Spacer Rings	Nylon 6 Plastic
Brush	Stainless Steel shaft, Nylon bristles
Input Hopper & Output Chute	ABS (Acrylonitrile-Butadiene-Styrene) Plastic
Trim Tote	HDPE 2 (High-density Polyethylene)

POWER SPECIFICATIONS & REQUIREMENTS

COMPONENT	SPECIFICATION / REQUIREMENT	
Vacuum Motor	5 HP	
Cutter Motor:	0.75 HP	
Tumbler Motor:	1/8 HP	
Electrical Requirements	Single Phase: 240V, 30 amps. Three Phase: 208V, 22 amps.	
Mobius Power Receptacle	Three Phase: L15-30R 	Single Phase: L6-30R 

PARTS

All parts for the Mobius are manufactured in-house. If a Mobius operator ever finds themselves in need of a replacement part, we will be able to expedite delivery of that part from our production facility in Surrey, BC to locations throughout Canada and the United States. In most cases, next-day delivery would be possible.

SENSORS

When a sensor is activated, the relevant component on the Fault Display is illuminated, the interior lights illuminate red and the Control Panel Display provides information on the fault.

The following is a summary of the sensor systems built into the M108.

SENSOR	FAULT
Trim Tote	When Trim Tote reaches capacity (trim material makes contact with the sensor), machine shuts off and will not start until fault is cleared.
Input Hopper	When not properly installed, machine remains in fault mode and will not start up.
Output Chute	When not properly installed, machine remains in fault mode and will not start up.
Separator Housing	When not properly installed, machine remains in fault mode and will not start up.
Machine lid	When not properly closed, machine remains in fault mode and will not start up.



MOBIUS
TRIMMER

mobiustrimmer.com

[@mobiustrimmer](https://twitter.com/mobiustrimmer)

CREATED BY:



ETEROSTM
divergent thinking

eteros.com [@eteros](https://twitter.com/eteros)