



# AKVA FNC8 v 2.0

**A powerful and robust remote net cleaning rig. Easy to operate and maintain with a new and intuitive visual presentation.**

The Flying Net Cleaner 8 has a cleaning efficiency that outperforms nearly every other option. It is built with standard ROV components that are easy to clean and disinfect. It also has several built-in auto features and advanced IP camera systems and sensors for complete monitoring during the entire cleaning process.



## Principal advantages

- Efficiently clean nets and lice skirts without damage and with minimal waste spread
- Prepared for up to 250 bar pressure and 750 L/min - facilitated for pressure below 100 bar
- Robust components and rugged design
- Easy to operate with automated functions
- Open construction, easy to maintain and disinfect
- Thrusters propulsion (no damages from wheels/tracks)
- Graphic visual presentation
- Advanced control system prepared for autonomous operation

# SPECIFICATIONS

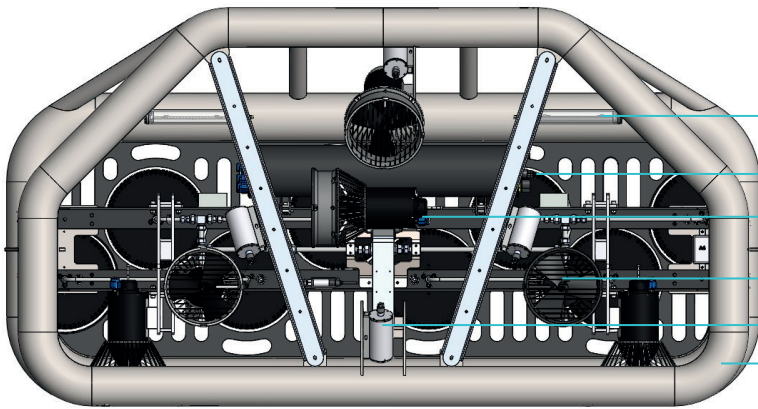

- Four LED lights with 3000lux
- Eight high flow cleaning discs
- Four Ethernet IP HD cameras
- Six thrusters
- Fiber tether
- Durable frame

## FNC

Vehicle LWH	265 x 110/140 x 66cm
Max. working depth	75m
Frame	AISI 316 and Anodized AL6082-T6
Buoyancy	Air filled tubing
Weight in air	395kg
Cleaning area FNC	260cm width
Cleaning area per hour	5.000m <sup>2</sup> /hour (theoretical)
Working pressure cleaning system	80 - 250 bar
Water consumption	309 - 715 L/min
Nozzle sizes	1.2 mm - 2.0 mm
Power input (rec.63 Amp.)	230V AC - 20 kW, 3 phase 50 - 60Hz.
Thrusters	6 ea. Thrusters
Speed along net	0 - 1,5 meter/s
Camera	4 x Ethernet IP HD cameras
Lights	4 x Sperre LED-Light 3000lux
Auto functions	Auto Depth, Auto Heading Water press. cleaning unit
Sensors	Depth sensor Moist sensor, electronics Disc speed sensors Disc water pressure sensor
Tether	100m neutral
Water supply hose, high pressure	100 meter 1 inch complete with fitting, WP 250 bar

## TOPSIDE POWER AND CONTROL STATION

Control system	Option 1: Pilot chair with integrated control system Option 2: Mobile pilot console with control system
Screens	One screen for 4k video picture and overlay
Overlay, data presentation	Text generator, date, time, depth, sensor information, etc.
Video recording	Recording, 4 channel
Power cabinet	Main switch, hour counter, fuses, insulation monitoring, V/A meter
Graphic visualization	Graphic presentation of FNC orientation and depth
Position and graphic visualization (option) with remote control	Shows FNC 3D position in the cage

## STANDARD TOOLING AND SPARES

Tooling kit, 1. standard. Included	Instrument megger/ multimeter Fuses, Silicone oil, Molycote 111, Molycote 44, Laser pen tools Consumables
------------------------------------	--

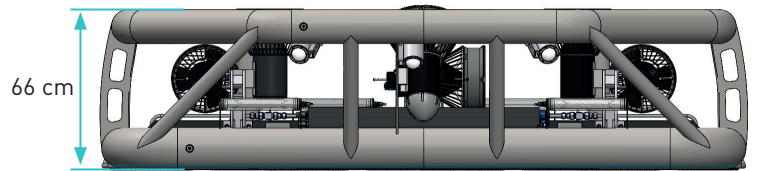
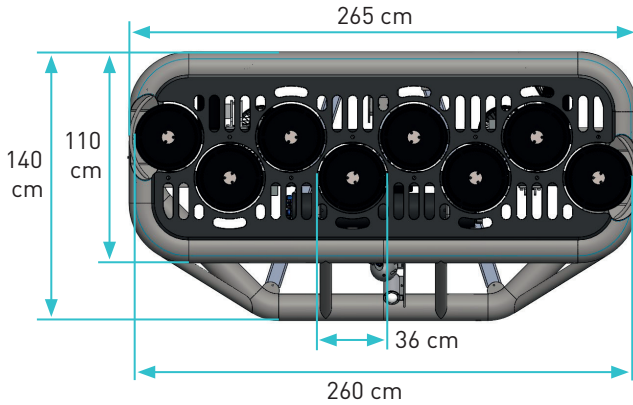

AKVA FNC8 v 2.0

## OPTIONAL SYSTEM EQUIPMENT

Winch for tether and high pressure water hose      Capacity 100 meters per cable/hose. Electric driven with slip ring for fiber and power

Rollers and ducts for fluttering nets      Demands approx 100 liter/min. of extra water @200 bar

Stand for shipping, storage and service of the FNC8      Fork lift interface for easy moving

Lifting rig      Designed for safe and quick lifting of the FNC during the launch and recovery process

Disinfection tub      Custom made from high density polyethylene for easy disinfection

Mobile control room      Control container 2x2 m

### Water consumption

Nozzle	FNC pressure in bar	Cons. per nozzle L/min	Theo. cons. 24 nozzles L/min
1.2 mm	150	11	309
1.2 mm	180	12	309
1.2 mm	200	12.6	309
1.5 mm	150	17.8	445
1.5 mm	180	19.5	522
1.5 mm	200	20.6	537
1.7 mm	80	11	260
1.7 mm	100	17.9	445
1.7 mm	150	21.9	522
1.7 mm	180	24	623
1.7 mm	200	25.3	623
2.0 mm	100	24.6	623
2.0 mm	150	30.1	715



FNC8 stand



FNC control rack



Lifting rig



Pilot chair & Pilot console



Disinfection tub



Winch

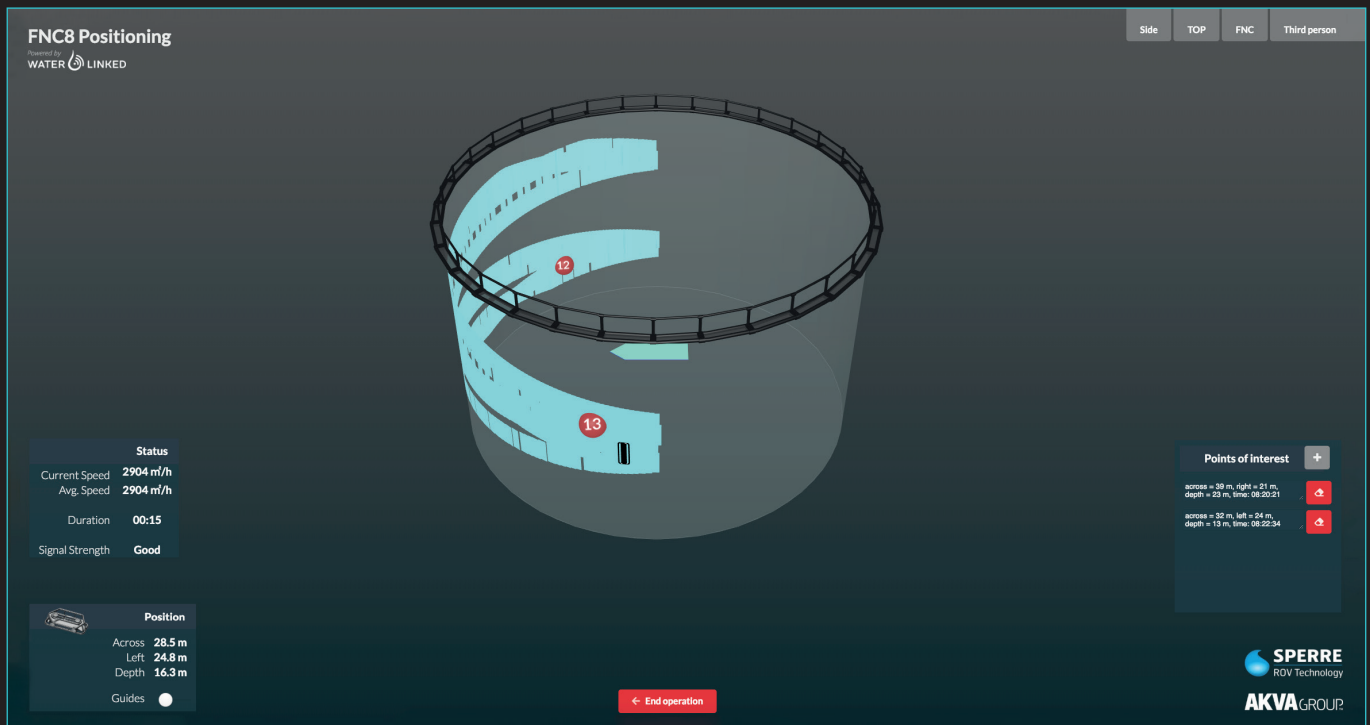

The new graphic visual presentation shows the FNC8 cleaner's position in 3D, giving you full control of how it moves in the pen. You can also mark points of interest during the cleaning process for future inspections.

## High pressure pumps - choose quality!

AKVA group offers a wide range of compatible high pressure pumps. A high-quality high-flow system is key to successful net cleaning.



The pump systems are delivered with a flexible and user-friendly control system that ensures safe and efficient operations.



The pump and engine are placed on a powerful, vibration dampened frame.



We offer customized solutions to suit your requirements and on-site conditions.



## A PATENTED SOLUTION



The AKVA FNC8 is a patented solution produced by the world-leading Norwegian ROV manufacturer Sperre AS.

This ROV cleaner can be used in all types of cages. The solution constitutes an economical and safe way to clean cages - this is the future of maintenance and inspections!