

## Installation Instructions for AGL secondary connector kits

### Read these instructions before installation:

#### Important:

- Only personnel qualifying to work with high voltage equipment and circuits are allowed to do the installation.
- Make sure the circuits are disconnected from the voltage supply and correctly grounded. Never connect or disconnect live circuits. Voltage is lethal.
- Follow the local instructions for safety precautions or refer to the FAA advisory circular AC150/5340-26 (maintenance of Airport visual Aid Facilities). Follow also Advisory circular AC150/5370-10 part XI Lighting installations. Always test the installation according to above mentioned documents and local instructions.
- Make sure that dimensions of the cable comply with the type of connector used. In case of any kind of non-compliance do not proceed with the installation.

Disconnect voltage supply and ground all circuits. *FAA advisory circulars standards: latest AC150/5340-26 and AC150/5370-10.* In case of non-compliance do not install.

| Secondary connectors for two core cable |            |                |                |
|---|------------|----------------|----------------|
| Plug                                    | Receptacle | Conductor size | Cable diameter |
| KD501                                   | KD502      | 1.5 – 2.5 sqmm | 8.5 – 13.5 mm  |
| KD501.1                                 | KD502.1    | 4.0 – 6.0 sqmm | 11.5 – 18.0 mm |
| KD501.2                                 | KD502.2    | 4.0 – 6.0 sqmm | 8.5 – 13.5 mm  |

| Secondary connectors for two single wires |            |                |                |
|---|------------|----------------|----------------|
| Plug                                      | Receptacle | Conductor size | Cable diameter |
| KD503                                     | KD503/R    | 1.5 – 2.5 sqmm | 2.8 – 4.0 mm   |
| KD503.1                                   | KD503.1/R  | 4.0 – 6.0 sqmm | 3.8 – 5.5 mm   |
| KD503.2                                   | KD503.2/R  | 4.0 – 6.0 sqmm | 2.8 – 4.0 mm   |

#### Contents:

- 1 Silicone grease tube
- 1 Body with connecting parts
- 1 Plug or receptacle housings
- Cleaning cloth
- Installation instructions

### SECONDARY CONNECTOR KIT ASSEMBLY

**Steps 1:** Clean approximately 20 cm of the cable end with a cleanser, i.e. spirit or equivalent and let dry.

**Step 2:** It is recommended to remove sharp edge of the cable insulation especially when the cable diameter is in the upper half of the cable diameter range.

**Step 3:** Open the front of silicon grease tube (1A) and dip the cable end in the silicone grease (1B). Push the cable through the housing before the stripping of wires.

**Step 4:** Clean the cable end again with cleanser, i.e. spirit or equivalent.

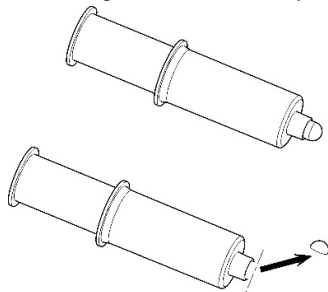

Figure 1A

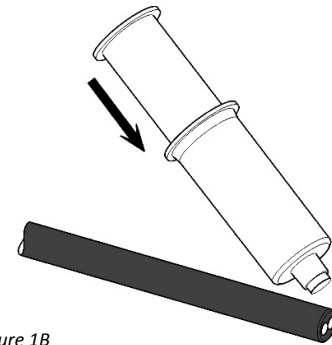

Figure 1B

#### Liability for defects

This product will perform within the recommended operational ratings when installed and operated in accordance with these instructions.

EFLA Oy liability is limited to replacement of component parts designed and manufactured by EFLA Oy which are proved to be defective in design, workmanship or material. For further details see our conditions of sale downloadable at [www.efla.net](http://www.efla.net)  
 Manufactured by EFLA OY KIPINATIE 3, 06150 PORVOO, Finland. Tel:+358 204 76 21 Fax: +356 204 76 2758

**Step 5:** Strip the sheath of a two core cable  $20 \pm 5$  mm for plugs (KD501-series), but only  $13 \pm 5$  for receptacles (KD502-series). Wires should be stripped up to  $8 \pm 1$  mm (2A).

**Step 6:** The insulation of single core cables (wires) should be stripped up to  $8 \pm 1$  mm (KD503 and KD503/R-series).

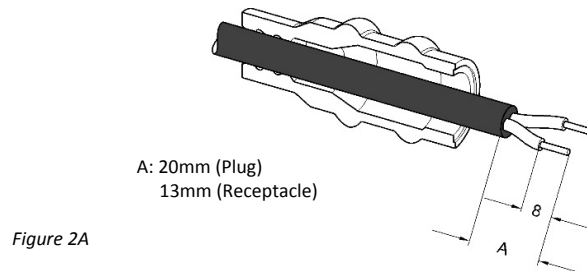

**Step 7:** Crimp the metal parts to conductors with a proper crimping tool and assure liable connection. Crimping tool suggestions for secondary connector kits: conductor size 1.5 – 2.5 sqmm - Elpress DKB 0760 and conductor size 4 – 6 sqmm – Elpress EWB 4099C. Other trademarks may be used if the installer verifies adequate crimping.

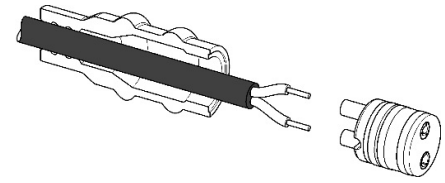
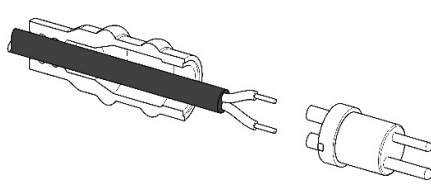

**Step 8:** Grease the body with silicone grease tube (4A). Note: piston must be pushed to the end for maximizing the silicon grease volume inside of the housing. Pull the housing over the body and make sure that the housing is correctly in place (4B). If the PMR 755 sealing unit is used with a receptacle, grease lightly the inner surface of the ring and push it over the housing.

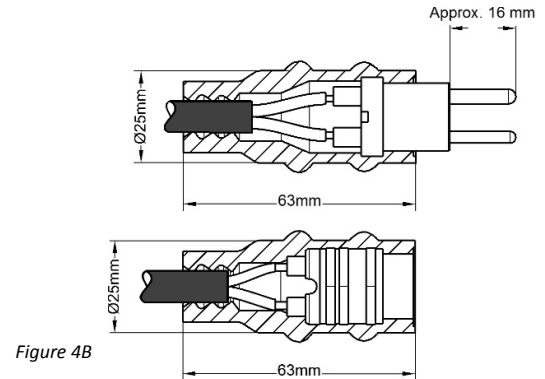
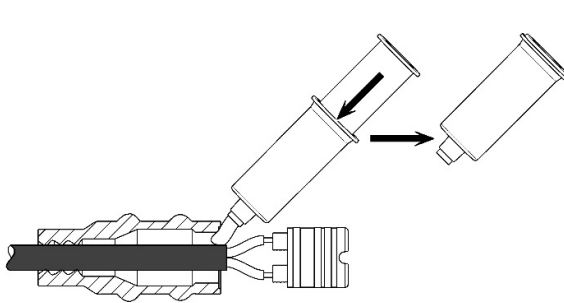
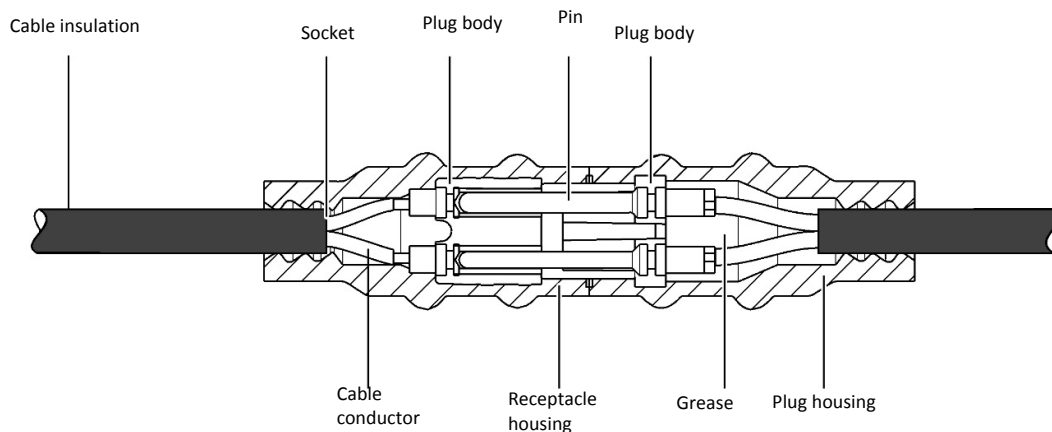

Figure 4A

Figure 4B



**Additional tape securing:** After the connectors are plugged together make sure that the outer surface of connectors are clean and dry. Otherwise clean the outer surface of the connectors between plug and receptacle connectors min. 40 mm (1.5 inch) with aliphatic solvents (spirit or equivalent). Wrap the joint where the connectors come together with at least one layer self-vulcanizing rubber tape (Scotch 23 or 130C) so that one half lapped extends at least 20 mm (0.8 inch) of each side of joint. Wrap at least one layer of PVC electrical tape (Scotch Super 33+ or equivalent) over the rubber tape.

**Disconnection:** Remove possible tape from the joint of plug and receptacle. Pull the connector apart without bending.

**Liability for defects**

This product will perform within the recommended operational ratings when installed and operated in accordance with these instructions.  
EFLA Oy liability is limited to replacement of component parts designed and manufactured by EFLA Oy which are proved to be defective in design, workmanship or material. For further details see our conditions of sale downloadable at [www.efla.net](http://www.efla.net)  
Manufactured by EFLA OY KIPINATIE 3, 06150 PORVOO, Finland. Tel:+358 204 76 21 Fax: +356 204 76 2758



**Liability for defects**

This product will perform within the recommended operational ratings when installed and operated in accordance with these instructions.

EFLA Oy liability is limited to replacement of component parts designed and manufactured by EFLA Oy which are proved to be defective in design, workmanship or material. For further details see our conditions of sale downloadable at [www.efla.net](http://www.efla.net)  
Manufactured by EFLA OY KIPINATIE 3, 06150 PORVOO, Finland. Tel:+358 204 76 21 Fax: +356 204 76 2758