

Installation Instructions for KDR-600 Series (Primary Connector Kit - Resin Type)

Important:

- Check that all components are in the plastic bag as per Figure 1A below.
- Read carefully through the Safety Instructions baled on the resin bag and prepare yourself accordingly.
- Do not open the aluminum bag until after Step 4 of these installation instructions.
- In case the resin containing aluminum bag is damaged, has cuts/holes or it is swollen - do not use the resin. Check that the resins last date of use has not expired (mm/yyyy at top right).
- Check www.efla.net for possible updates of installation instructions.
- Note: Installation temperature range is +5 C to +45 C. Stocking temperature range is +10 C to +40 C.

Disconnect voltage supply and ground all circuits. *FAA advisory circulars standards: latest AC150/5340-26 and AC150/5370-10.* In case of non-compliance do not install.

EFLA type (Screened Cable)	EFLA type (Unscreened cable)	FAA L-823	Conductor Size Options	Cable Diameter
KDR600	KDR610	Style 3, Style 10	6mm ² (AWG 8., up to 19 strands)	9 – 19mm
KDR600.2	KDR610.2	Style 3, Style 10	6mm ² (AWG 6, 16mm ² stranded)	9 – 19mm

Contents: Resin Bag (resin + hardener), Gloves, Sandpaper, Installation instructions, 2 strips of self-vulcanizing tape and the components labeled in figure 1A below.

- Plug elastomer housing (male)
- Receptacle elastomer housing (female)
- End cap (x2)
- Protective cap (x2)
- Locking device
- Socket
- Guiding pin (plastic)
- Metal pin
- Screen conducting wire and ring (x2)
- Screw type connector (6mm²)
- Plastic gauge
- Air holes

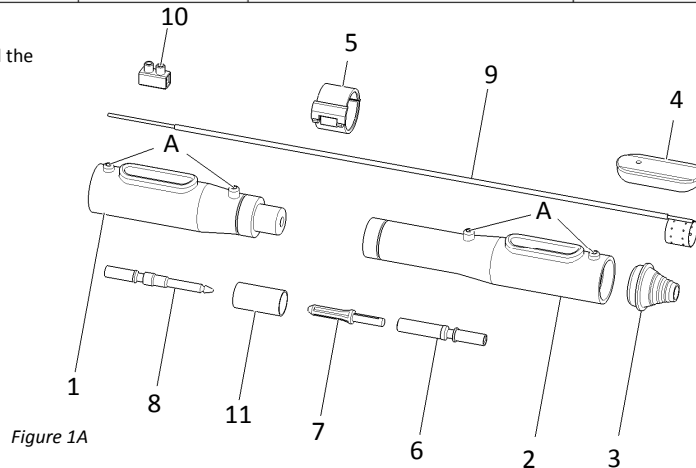

KDR600 ASSEMBLY

Step 1: Cut cable and pass it through the end cap component. See ABCD dimensions table (1A) for cutting options. Strip cable shield layers by dimensions shown in figure below (1B) and for proper resin adhesion, roughen cable outer shield and core insulation with sandpaper as in (1B). For screened cables: see to it that all particles of semi-conductive layer have been removed.

Table 1A

LETTER	CABLE Ø mm
A	8,00 – 10,50
B	10,30 – 13,00
C	13,00 – 15,50
D	15,50 – 19,00

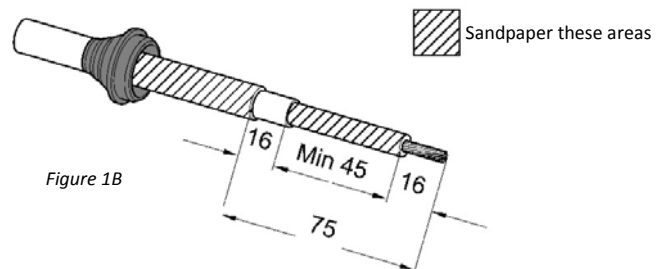

Step 2: Place 1 screen conducting wire's ring around the cable shield on the area shown (2A). Squeeze it according to the stages shown (2B). Unwrap 1 self-vulcanizing tape and place around the wire's ring.

Strip of Self-vulcanizing tape wrapped around the earthing point

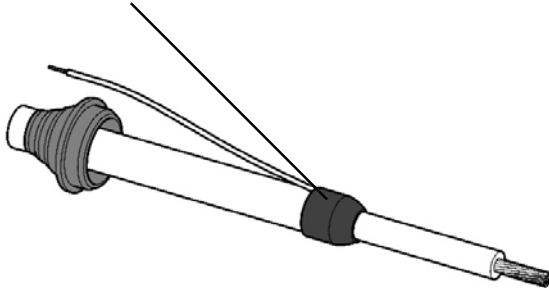

Figure 2A

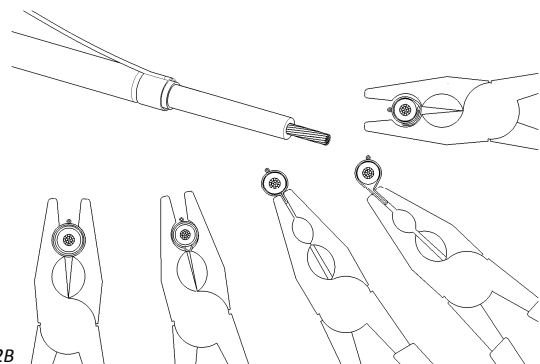

Figure 2B

Liability for defects

This product will perform within the recommended operational ratings when installed and operated in accordance with these instructions.

EFLA Oy liability is limited to replacement of component parts designed and manufactured by EFLA Oy which are proved to be defective in design, workmanship or material. For further details see our conditions of sale downloadable at www.efla.net

Manufactured by EFLA OY KIPINATIE 3, 06150 PORVOO, Finland. WWW.EFLA.NET Tel:+358 204 76 21 Fax: +356 204 76 2758

Step 3: Use tool e.g. Elpress 4099 and crimp the metal pin to the cable's core conductor with a proper crimping tool (3A). Place assembled piece inside the plug elastomer housing and pass screen conducting wire out through the housing's opening, then secure end cap to housing (3B). Make the inner surfaces of the two housings free from foreign particles and moisture before pouring the resin (Step 4). Verify the nominal dimension 27 mm using the plastic gauge, tolerance area 26,6 – 27,3 mm in Fig. 3B.

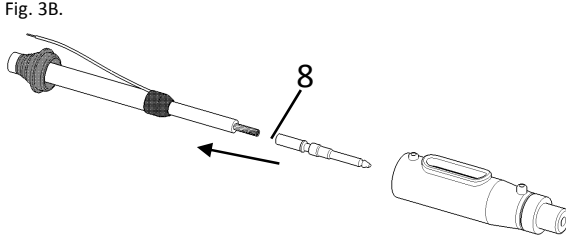

Figure 3A

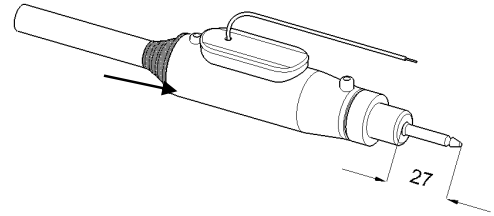

Figure 3B

Step 4: Repeat similar procedure of Steps 1 and 2 above for the other half of the cable. Afterwards, crimp the socket to the cable's core conductor as seen below (4A). Connect plastic guiding pin onto socket before placing assembled piece inside the receptacle elastomer housing. Socket shall be at same level as the bottom of the socket housing; see Fig. 5B, point B. Secure end cap to housing (4B). Take plastic guiding pin away after assembling. Verify socket placement using the plastic gauge.

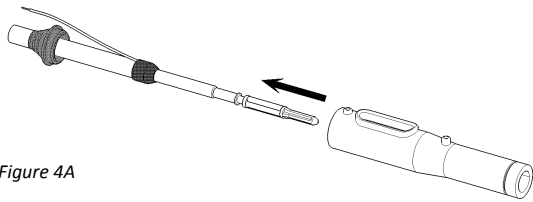

Figure 4A

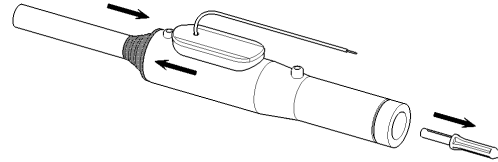

Figure 4B

Step 5: Mix resin and hardener according to the illustrated drawings 1 - 7 on the side of the silver resin bag. Take note of "Pot Life" instructions. Place both elastomer housings separately on a horizontally flat surface and completely fill each opening slowly with the mixed resin until resin penetrates through the air holes (5A). Place the protective caps over each filling area with screen conducting wires through each protective cap's hole. WAIT 6 HOURS FOR RESIN TO CURE (HARDEN). Do not bend and make sure that the whole assembly is free from any strain during the 6 hours curing stage.

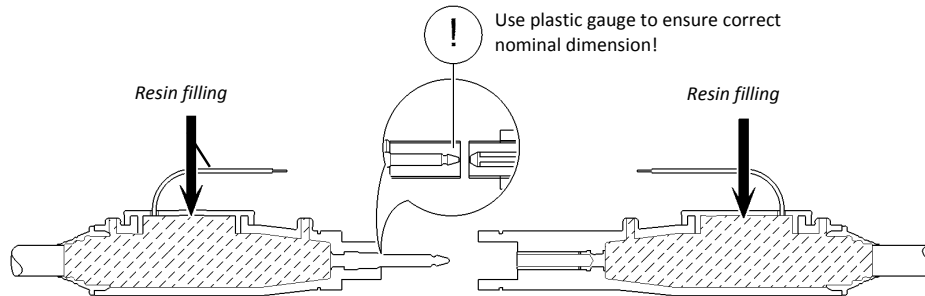

Figure 5A

Step 6: After 6 hours curing, connect elastomer housings together and ALWAYS INSTALL THE LOCKING DEVICE (5) in order to avoid separation or bending. Connect the two screen conducting wires together using the Screw type connector. (6A) To disconnect, remove the locking device and firmly pull the connectors apart. The plastic guiding is left out of the assembly (6B).

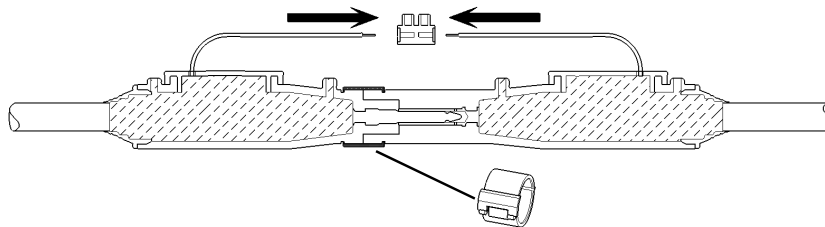

Figure 6A

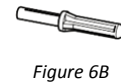

Figure 6B

The complete assembly is shown below. (6C)

- 12. Self-vulcanizing tapes
- 13. Cables
- 14. Resin filled areas

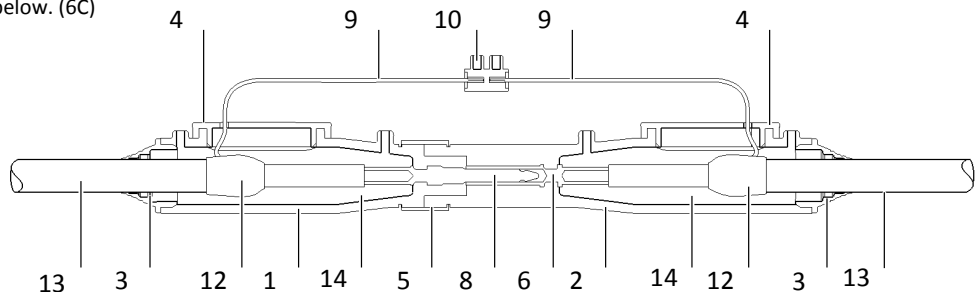

Figure 6C

Liability for defects

This product will perform within the recommended operational ratings when installed and operated in accordance with these instructions.

EFLA Oy liability is limited to replacement of component parts designed and manufactured by EFLA Oy which are proved to be defective in design, workmanship or material. For further details see our conditions of sale downloadable at www.efla.net

Manufactured by EFLA OY KIPINATIE 3, 06150 PORVOO, Finland. WWW.EFLA.NET Tel:+358 204 76 21 Fax: +356 204 76 2758