



User's Manual

COGENTIX MEDICAL

Flexible Fiberoptic Bronchoscope

BRS-4000

and Slide-On[®] EndoSheath[®] Technology

NOTE: Federal (USA) law restricts this device to sale by, or on the order of, a physician or other appropriately licensed medical professional.

www.cogentixmedical.com

©2009, 2010, 2012, 2013, 2014, 2015 Cogentix Medical, Inc. All rights reserved.
Printed in the United States of America.

The information contained herein is the exclusive and confidential property of
Cogentix Medical, Inc. No part of this manual may be disclosed or reproduced in
whole or in part without permission from Cogentix Medical, Inc.

How to Use This Manual

This User's Manual contains the recommended procedures for preparing and using the Cogentix Medical **BRS-4000** Flexible Fiberoptic Bronchoscope and the **Slide-On® EndoSheath® Technology**. It is intended for physicians and other medical personnel who will come in contact with the equipment before, during, and after any patient procedures with it. The manual also contains pertinent information on the proper care and handling of the equipment. Please read and become familiar with this entire manual before using the endoscope and accessories.

The manual contains the following information:

- The endoscope's intended use
- Description of the endoscope and the **Slide-On® EndoSheath® Technology**
- Components and features of the endoscope and peripheral equipment used in conjunction with the endoscope
- Complete instructions on endoscope preparation, inspection, operation, reprocessing, and storage
- Warning and Caution statements that must be observed by endoscope users to ensure patient and user safety

If you are a **first time endoscope user**, Cogentix Medical strongly recommends that you read this manual from beginning to end and become intimately familiar with the endoscope and its use.

If you are an **experienced endoscope user**, select specific chapters and/or sections that pertain to features and procedures that you are using.

Organization of this Manual

Following is a list of the chapters included in this User's Manual. Each chapter's title is listed at the top of all pages, so that you can quickly access the information you need.

Chapter 1, Symbols and Terms — This chapter defines the symbols on the endoscope and peripheral equipment. There is also a brief list of the terms that are commonly used in the manual.

Chapter 2, Important Information — The information in this chapter is a summary of critical Warning and Caution statements in the manual.

Chapter 3, Endoscope and Accessories — Introduces the **BRS-4000** Flexible Fiberoptic Bronchoscope, the **Slide-On® EndoSheath® Technology**, and compatible peripheral equipment. This chapter includes instrument diagrams, identifies components, and defines their functions.

Chapter 4, Installing and Removing the Slide-On® EndoSheath® Technology — The **Slide-On® EndoSheath® Technology** is a sterile, single use barrier placed over the endoscope's Insertion Tube before the procedure, and removed and discarded after the procedure is completed. This chapter includes the procedures for installing the Sheath prior to the procedure, and removing it when the procedure is over.

Chapter 5, Preparation, Inspection and Operation — This chapter describes how to prepare the endoscope and peripheral equipment for use, and how to assemble the equipment into a system. This chapter also leads you through a detailed inspection procedure to confirm that the equipment is undamaged and working properly before it is used in a procedure.

Chapter 6, Reprocessing — This chapter contains important instructions on the proper cleaning, disinfection, and sterilization of the endoscope before its first use and after each subsequent use. Strict adherence to the instructions in this chapter will render the endoscope "patient-ready" for each procedure.

Chapter 7, Care and Storage — If the equipment will not be used for a prolonged period, refer to this chapter for instructions on safe, secure storage.

Chapter 8, Troubleshooting — Describes possible problems that may be encountered with the endoscopic system, and suggests corrective actions to take towards resolving minor problems.

Chapter 9, Warranty and Service — This chapter contains the terms of the Cogentix Medical warranty on the endoscope, any restrictions that apply and user actions that may void the warranty if taken. This chapter also includes shipping instructions in case the endoscope must be returned to Cogentix Medical for repair or service.

The **Appendix** contains the technical specifications for the **BRS-4000** Flexible Fiberoptic Bronchoscope, and infection control information.

Additional Information

The information in this User's Manual is subject to change without notice. If you have any questions regarding any of the material contained in this User's Manual, or wish to confirm that this is the most comprehensive information available for these products, please contact your local distributor or Cogentix Medical Customer Service Department at 866 258-2182 (toll free in U.S.) or (+1) 952-426-6189 (international).

Table of Contents

How to Use This Manual	i
Organization of this Manual	i
Additional Information	ii
1 Symbols and Terms.....	1
Symbols	1
Terms	2
2 Important Information	3
Intended Use	3
User Qualifications	3
Reprocessing	4
Maintenance and Repair.....	4
Signal Words	4
Important Safety Precautions.....	4
Preparation, Inspection and Assembly	5
During Use	7
Reprocessing	8
3 Endoscope and Accessories	9
Inspect the Standard Set	10
Equipment Diagrams.....	11
BRS-4000 Flexible Bronchoscope	11
BF-2.8*, BF-2.1 and BF-1.5 Slide-On® EndoSheath® Technology	14
BF-0 Slide-On® EndoSheath® Technology	16
Installation Stand	17
Accessories.....	18
BLS-1000 Battery Powered Light Source	18
Light Guide Cables.....	18
Other Light Sources.....	18
Add-On Camera Systems.....	18

Table of Contents

Leak Testing	19
Reprocessing	19
Therapeutic/Diagnostic Accessories.....	19
Light Source Adapters.....	20
4 Installing and Removing the Slide-On® EndoSheath® Technology ...	21
Install the Slide-On® EndoSheath® Technology	21
Prepare the Endoscope and Sheath.....	22
Insert the Endoscope Into the Sheath	22
Connect Suction Tubing.....	23
Complete System Assembly	24
Remove the Slide-On® EndoSheath® Technology.....	25
5 Preparation, Inspection and Operation	27
Preparation and Inspection.....	27
Endoscope Operation with BLS-1000 Battery Powered Light Source.....	29
Endoscope Operation – Other Light Sources	30
Suction.....	31
Instilling Fluids	31
Inserting Accessories.....	31
Electrosurgical Devices / Accessories	32
Laser Devices / Accessories	34
6 Reprocessing	35
Reprocessing Steps.....	36
Leak Testing.....	36
Attach the Leak Tester to the Endoscope.....	37
Pressurize the Endoscope.....	37
Cleaning / Disinfection / Sterilization	39
Use of the Vent Cap	39
Cleaning after Slide-On® EndoSheath® Technology Use.....	39
High-Level Disinfection and Sterilization.....	40
Recommended Disinfection and Sterilization Procedures.....	40
Acceptable Reprocessing Materials.....	41

Incompatible Methods 41

High-Level Disinfection Protocol 42

 Cleaning..... 42

 Disinfection 42

 Rinsing..... 42

Ethylene Oxide (EtO) Gas Sterilization..... 43

 EtO Gas Sterilization Parameters..... 43

 After EtO Gas Sterilization 43

STERRAD® and STERIS® Sterilization..... 44

7 Care and Storage 45

 Storage..... 45

 Disposal..... 45

8 Troubleshooting..... 47

9 Warranty and Service 53

 Warranty Information 53

 Cogentix Medical Service Information..... 53

 Shipping to Cogentix Medical or Distributor 54

Appendix..... 55

 Specifications 55

 Infection Control Information..... 56

Table of Contents

Index of Figures

Figure 2-1: Sheath Alignment	6
Figure 3-1: BRS-4000 Flexible Bronchoscope.....	11
Figure 3-2: BRS-4000 Flexible Bronchoscope – Control Body	12
Figure 3-3: BF-2.8*, BF-2.1 and BF-1.5 Slide-On® EndoSheath® Technology.....	14
Figure 3-4: BF-0 Slide-On® EndoSheath® Technology.....	16
Figure 3-5: Installation Stand	17
Figure 3-6: Light Source Adapters (Light Guide Sleeves)	20
Figure 4-1: Sheath Alignment	23
Figure 6-1: Leak Tester Connection.....	37
Figure 6-2: Opening the Vent Valve.....	39

Index of Tables

Table 3-1: Standard Set Components	10
Table 6-1: STERRAD® and STERIS® Validated Systems/Cycles	44
Table 8-1: Troubleshooting	48

1 Symbols and Terms

Symbols

The symbols listed below can be found on the **BRS-4000** Flexible Bronchoscope and/or on other components of the endoscopic system.



Type BF applied part (Safety degree specified by IEC 60601-1)



Alerts the user to the presence of important operating, maintenance, and service instructions. Refer to the user's manuals for warnings and safety precautions associated with equipment used in the procedure.



Serial number of the endoscope



Equipment bearing this mark has been designed, tested, and certified as essentially compliant with all applicable European Union (EU) regulations and recommendations.



Up position for the angulation lever



Down position for the angulation lever



Underwriters Laboratories Component Recognition Mark



STERRAD[®] and STERIS[®] Reprocessing Compatibility
Refer to Chapter 6, Reprocessing (endoscope **must** feature the (S) symbol for compatibility to apply)



Products do not contain natural rubber latex



Consult Instructions for Use



The presence of this symbol on the product or packaging indicates that the device is RoHS compliant.

Terms

Throughout this manual, the following terms are used:

“Endoscope” or **“Bronchoscope”** refers to the Cogentix Medical **BRS-4000** Flexible Bronchoscope.

“Slide-On[®] EndoSheath[®] Technology” or **“Sheath”** refers to the disposable **BF-2.8*** and **BF-2.1 Therapeutic Slide-On[®] EndoSheath[®] Technology**, and/or the **BF-1.5** and **BF-0 Diagnostic Slide-On[®] EndoSheath[®] Technology**.

*Available in Select Markets Only

2 Important Information

The information in this chapter is essential for the correct and safe operation of the **BRS-4000** endoscope and **Slide-On® EndoSheath® Technology**. Please read and understand this information before preparing or using the endoscope and any peripheral equipment with which it will be used.

Intended Use

The **BRS-4000** and **Slide-On® EndoSheath® Technology** are designed to be used for airway management of the trachea and other major passages of the lungs, and endoscopic treatment, diagnosis, and intubation of the airways. The instrument may be introduced via trans-oral or trans-nasal insertion, as per physician preference or anatomical requirements. Combined with accessory devices, the endoscope can be used to perform various diagnostic and therapeutic procedures.

Do not use this equipment for any purpose other than these intended uses.

User Qualifications

This equipment should only be used in a medical facility by or under the supervision of a physician trained in endoscopy. Use of the system does not require any deviation from standard bronchoscopy technique. However, the operator should have complete familiarity with the operation of the entire system prior to clinical use.

Only use the endoscope and peripheral equipment according to the instructions and under the operating conditions described in this User's Manual. Failure to do so could result in compromised safety, equipment malfunction and/or instrument damage.

For preparation of the device before use, and disassembly and proper cleaning after use, users should be adequately trained in the proper procedures. Failure to thoroughly understand these details, such as – but not limited to – **EndoSheath® Technology** installation and authorized disinfection protocols, may pose an infection-control risk and/or cause equipment damage.

If training assistance is desired from either the manufacturer or a local distributor, please contact Cogentix Medical Customer Service at 866 258-2182 (toll free in U.S.) or (+1) 952-426-6189 (international).

Reprocessing

The endoscope must be thoroughly cleaned, disinfected, and/or sterilized before its first use and after each subsequent use. This is the only way to ensure that a “patient-ready” endoscope is used in every procedure. See Chapter 6, **Reprocessing**, for information on all reprocessing equipment and procedures.

Maintenance and Repair

The endoscope does not contain user-serviceable parts. **Never** attempt to modify or repair the endoscope. Doing so may cause further equipment damage and/or compromise patient safety if the endoscope is subsequently used in a procedure. The endoscope may only be serviced / repaired at an authorized Cogentix Medical facility.

The endoscope should be thoroughly inspected before each procedure and should be periodically inspected to determine if there is damage or wear that requires attention.

Signal Words

Information included in this manual to warn users of the possibility of patient injury and/or equipment damage is signified by the Warning and Caution symbols below. Notes are also included, to advise of important information. Warnings, Cautions and Notes will appear throughout this manual. Carefully read and follow all statements.



Alerts the user to situations which, if not avoided, could result in death or serious injury.



Alerts the user to situations which, if not avoided, could result in moderate or minor injury to the user or patient. It also alerts the user to conditions and actions that could cause equipment damage.



NOTE: Indicates additional helpful information.

Important Safety Precautions

The following precautions should always be exercised when using the endoscope and all medical equipment to ensure the safety of all involved parties – user(s), patient(s), etc. They are summarized here in the order of the stages of the endoscope’s use.

Preparation, Inspection and Assembly

**WARNING**

The **BRS-4000** and **Slide-On® EndoSheath® Technology** are designed to operate as an integrated system. **Neither component can be used independently of the other.**

The **Slide-On® EndoSheath® Technology** is designed for a single patient use only. **Do not reuse** or attempt to re-sterilize the Sheath. For installing the Sheath in a sterile environment, users should wear two (2) pairs of sterile gloves. Refer to Chapter 4, **Installing and Removing the Slide-On® EndoSheath® Technology**, for complete details.

Never **drop** this equipment or subject it to **severe impact** as it could compromise the functionality and/or safety of the unit. Should any of the equipment be mishandled or dropped, do not use it. Return it to an authorized Cogentix Medical service facility for inspection and repair.

While the Sheath is being installed, the Bronchoscope should move freely without the application of force. Should **ANY** resistance be encountered, verify that the Sheath's channel is properly aligned.

Carefully inspect all equipment before using it in a procedure, and do not use any equipment that is damaged or excessively worn. Doing so could lead to patient injury and/or further damage to the equipment.

If inspection reveals difficulty in articulation of the endoscope's Distal Bending Section, the endoscope may be damaged. Do not use the endoscope in this case. Doing so could cause patient injury, and may result in further damage to the endoscope.

If the channel is misaligned as shown in Figure 2-1, straighten the channel before continuing endoscope insertion. If the problem continues, refer to Chapter 8, **Troubleshooting** for further instructions. If this does not help solve the problem, contact your local distributor or call Cogentix Medical Customer Service Department.



NOTE: The Cogentix Medical BRS-4000 Flexible Bronchoscope and Slide-On® EndoSheath® Technology are not made with natural rubber latex.

Important Information

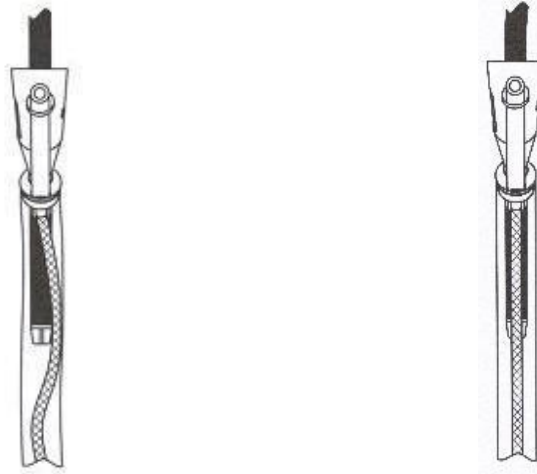

MISALIGNED

ALIGNED

Figure 2-1: Sheath Alignment

CAUTION

All devices that are connected to the Bronchoscope must be Classified Medical Equipment. Before using any additional equipment, confirm that it complies with the appropriate end-product safety standard (such as IEC 60950-1) and the Standards for Medical Electrical Equipment, UL 60601-1 or IEC 60601-1, and Safety Requirements for Medical Electrical Systems, IEC 60601-1-1.

DO NOT expose the Sheath to alcohol or other cleaning agents prior to use.

The Working Channel of the **BF-2.8*** and **BF-2.1 Slide-On® EndoSheath® Technology** accommodates instrumentation indicated by the accessory manufacturer to be compatible with a 2.8 mm and 2.1 mm (respectively) or smaller working channel. All instrumentation must be tested for compatibility with the channel prior to clinical use. If assistance is needed to determine compatibility, contact your local distributor or Cogentix Medical Customer Service.

DO NOT allow liquids to get inside the Sheath prior to use. Doing so could damage the Sheath and/or the endoscope.

(*Available in select markets only)

During Use

WARNING

Exercise caution when using this equipment in the presence of a flammable anesthetic mixture containing air, oxygen or nitrous oxide. There is a possibility of fire or explosion.

If any component of the endoscopic system malfunctions during the procedure, or if the endoscopic image is lost or compromised, immediately move the endoscope's Distal Bending Section to the neutral position and slowly withdraw the endoscope from the patient. Using an endoscope that is not functioning properly could cause patient injury and/or further damage to the equipment.

DO NOT use any accessory instrumentation that is damaged. Doing so may result in instrumentation malfunction during the procedure, which could cause serious patient injury and/or further damage to the endoscope.

CAUTION

Always wear appropriate personal protective equipment when using the endoscope and/or Sheath, such as a gown, gloves, and face and eye shields.

Avoid excessive bending or twisting of the endoscope's Insertion Tube. Although they are designed to bend, excessive bending can damage the fiber bundles and internal components. Should the endoscope develop a severe kink or bend, do not attempt to straighten the Insertion Tube. Contact Cogentix Medical Customer Service for assistance.

Do not apply excessive pressure to the angulation lever, as it could damage the endoscope and lead to patient injury.

If resistance is encountered when inserting an instrument into the Sheath, do not force it, as it could damage the instrument, the Bronchoscope and/or the **Slide-On[®] EndoSheath[®] Technology**.

DO NOT attempt to advance an exposed needle or other sharp instruments through the working channel. Doing so could damage the Sheath's channel.

A thorough understanding of the principles and techniques involved in laser, electrosurgical and ultrasonic procedures is essential to avoid shock and burn hazards to both patient and medical personnel and damage to the device and other medical instruments. Ensure that insulation or grounding is not compromised.

DO NOT look directly at the intense light emitted from the endoscope tip to avoid the possibility of eye injury.

Reprocessing

WARNING

The endoscope must be properly reprocessed, by cleaning, disinfection and/or sterilization, before its first use and after each subsequent use. Using an endoscope that has not been properly reprocessed in a procedure presents an acute infection-control risk to both the patient and medical personnel performing or assisting in the procedure.

CAUTION

Always wear appropriate personal protective equipment when reprocessing the endoscope, such as a gown, gloves, and face and eye shields.

Use extreme care when reprocessing the endoscope. Do not forcefully pull, push, or drag wipes, towels, or cloths along the Insertion Tube. The use of excessive force could damage the endoscope.

DO NOT immerse the endoscope in disinfectant solution for long periods of time (**in excess of one 1 hour**). Prolonged immersions may damage the outer coverings of the endoscope and allow fluid infiltration.

DO NOT place the endoscope in or near contaminated areas after it has been reprocessed. Doing so can re-contaminate the endoscope and require reprocessing to be repeated.

DO NOT place the endoscope in awkward or confining areas between procedures as this could result in equipment damage.

3 Endoscope and Accessories

The Cogentix Medical **BRS-4000** Bronchoscope and **Slide-On® EndoSheath® Technology** are designed to perform safe, sterile, and efficient endoscopic procedures.

The two major components of the endoscopic system are:

- The **BRS-4000** Bronchoscope, which is shown in Figure 3-1 on page 11. The endoscope's Insertion Tube does not have a working channel. It contains the fiberoptic image and illumination bundles only.
- The disposable **EndoSheath® Technology**. The sterile, disposable Sheaths are installed over the endoscope's Insertion Tube, acting as a protective barrier to protect patients and users from the spread of potentially pathogenic materials. The **BF-2.8***, **BF-2.1** and **BF-1.5** Sheaths also contain working channels through which suction and/or accessory equipment can be used. The four types of Sheaths available for use with the **BRS-4000** are:
 - The **BF-2.8 Slide-On® EndoSheath® Technology*** (Figure 3-3 on page 14). This Sheath contains a 2.8mm (8.4Fr) channel through which suction can be performed, and/or accessory instruments can be inserted.
 - **The BF-2.1 Slide-On® EndoSheath® Technology** (Figure 3-3 on page 14). This Sheath contains a 2.1mm (6.3Fr) channel through which suction can be performed, and/or accessory instruments can be inserted.
 - The **BF-1.5 Slide-On® EndoSheath® Technology** (Figure 3-3 on page 14) has a 1.5mm (4.5Fr) channel that supports suction, but cannot accommodate the insertion of accessory instruments.
 - The **BF-0 EndoSheath® Technology** (Figure 3-4 on page 16) has no working channel and does not support the use of accessory instruments.

(*Available in select markets only)

Inspect the Standard Set



Do not use any equipment that is observed to be damaged or excessively worn. Doing so could lead to patient injury and/or further damage to the equipment.

When the endoscope is received from Cogentix Medical, immediately confirm that all of the items listed in Table 3-1 below have been shipped, and inspect them for damage. If any item is missing or damaged, do not use the endoscope. Contact Cogentix Medical to obtain a replacement part.

BRS-4000 BRONCHOSCOPE STANDARD SET	
COGENTIX MEDICAL CATALOG NO.	DESCRIPTION
04-4201	BRS-4000 Flexible Bronchoscope (Figure 3-1 and 3-2)
07-3060	Detachable Light Guide Cable 1.8m
07-6182	Cogentix Medical BRS-4000 Carrying Case
07-6015	Vent Cap
	BRS-4000 User's Manual (this manual)
OPTIONAL ITEMS AND ACCESSORIES (NOT SHIPPED WITH ENDOSCOPE)	
07-6160	Installation Stand, Floor Model
07-6161	Installation Stand, Clamp Model
07-6162	Installation Stand, Wall Mount
07-3053*	BLS-1000 Battery Powered Light Source Kit Includes Batteries and Battery Charger
07-3050	BLS-1000 Battery-Powered Light Source (Replacement)
07-3048*	Battery Charger (Replacement)
07-3049	Batteries (2 Batteries) (Replacement)
07-6010	Endoscope Leak Tester
See List on Page 20	Light Guide Sleeve Adapter
SLIDE-ON® ENDOSHEATH® TECHNOLOGY (NOT SHIPPED WITH ENDOSCOPE)	
04-4103	BF-2.8 Therapeutic Slide-On® EndoSheath® Technology** (2.8mm Working Channel) for the BRS-4000 Bronchoscope (Figure 3-3) **Available in select markets only
04-4101	BF-2.1 Therapeutic Slide-On® EndoSheath® Technology (2.1mm Working Channel) for the BRS-4000 Bronchoscope (Figure 3-3)
04-4102	BF-1.5 Diagnostic Slide-On® EndoSheath® Technology (1.5 Channel) (Figure 3-3)
04-4105	BF-0 Diagnostic Slide-On® EndoSheath® Technology (No Channel) (Figure 3-4)

Table 3-1: Standard Set Components

***Contact distributor for region-specific configuration**

Equipment Diagrams

BRS-4000 Flexible Bronchoscope

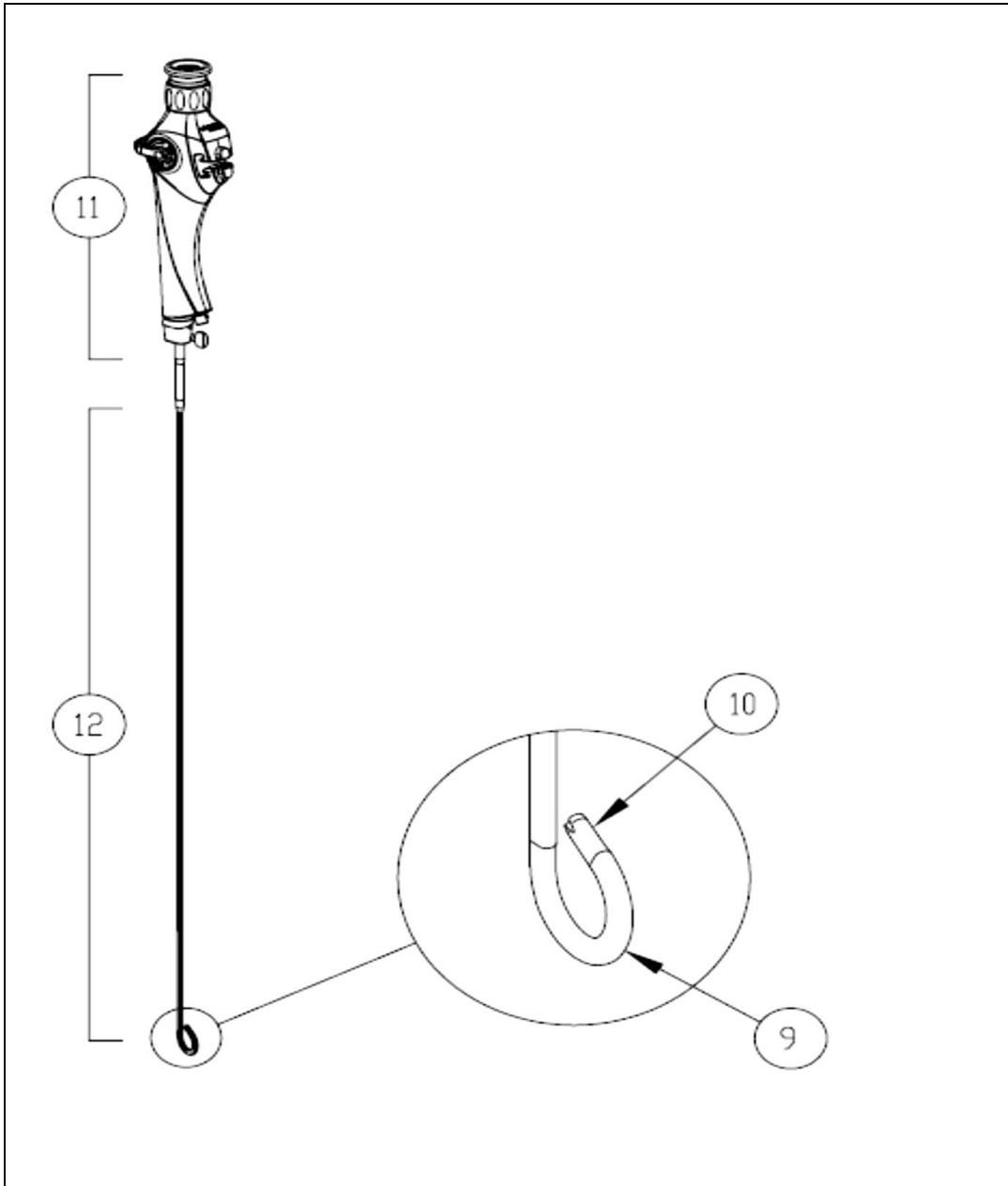

Figure 3-1: BRS-4000 Flexible Bronchoscope

BRS-4000 Flexible Bronchoscope Control Body

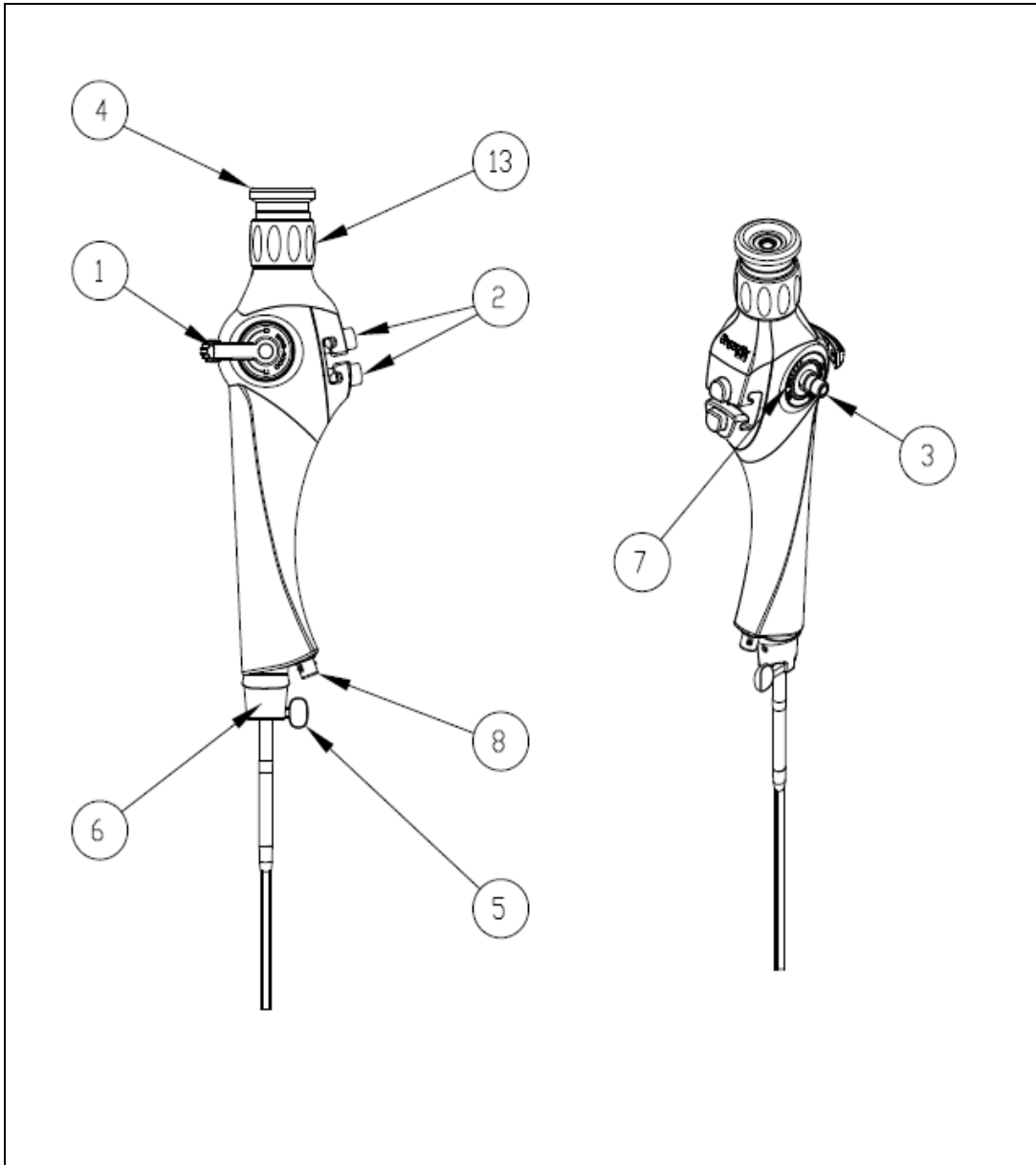

Figure 3-2: BRS-4000 Flexible Bronchoscope – Control Body

Instrument Components

Endoscope and Control Body (Figures 3-1 and 3-2):

1. **Angulation Lever:** This integral component of the Control Body controls the endoscope's Distal Tip deflection.
2. **Pinch Valve:** Secures the EndoSheath[®] Tubing to regulate suction during use.
3. **Light Guide Cable Connector (Light Post):** One end of the Detachable Light Guide Cable is inserted into the external Light Source to allow light to be projected to the endoscope's Distal Tip. The other end of the Cable is attached to this Connector on the Control Body.
4. **Eyepiece/Ocular:** Located at the top of the Control Body, this feature allows the user to view the image directly. Alternatively, a standard video camera, still photography system, or teaching attachment can be connected to the eyepiece, allowing the image to be displayed on a video monitor and/or photographed.
5. **Locking Knob:** Mates with the EndoSheath[®] Connector to secure the **Slide-On[®] EndoSheath[®] Technology** to the endoscope.
6. **EndoSheath[®] Interface:** Located at the base of the Control Body, this component secures the disposable **Slide-On[®] EndoSheath[®] Technology** to the endoscope.
7. **Identification Ring:** Located on the Control Body next to the Light Guide Cable Connector (Light Post); includes the Serial Number which is a unique number identifying the endoscope. Also includes the Underwriters Laboratories (UL) symbol indicating the fiberscope is recognized as a component which can be used in connection with add-on components such as light sources and camera attachments; and includes the (S) symbol, which indicates the endoscope can be sterilized using a validated STERRAD[®] or STERIS[®] system. The endoscope must feature this symbol on the ID ring in order for STERRAD[®] or STERIS[®] compatibility to apply.
8. **Vent Valve:** When the Vent Cap is connected here, this Valve allows access to the interior of the endoscope for EtO or STERRAD[®] Gas Sterilization, and should be connected during transport. The Vent Cap **must** be attached to this Valve prior to Gas Sterilization and prior to shipping. The Valve is also used as a Leak Tester Connector for Leak Testing.
9. **Distal Bending Section:** Deflects up and down when the Angulation Lever is actuated by the user.
10. **Distal Tip:** The terminating point of the endoscope's image fiber bundle (Objective Lens) and light-guide fiber bundles (Light Guides).
11. **Control Body:** This segment allows physician control over endoscopic functions.
12. **Insertion Tube:** This component, along with the Distal Tip, is the part of the endoscope that is inserted into the patient.

13. **Diopter Adjustment Ring:** Located on the Control Body, this ring turns clockwise or counterclockwise to adjust the image until it is clearly focused. When a video camera, still photography system, or teaching attachment is used, the white dot on the control body must be aligned with the white dot on the Diopter Adjustment Ring. When using an add-on camera, use the Focus Ring on the camera to adjust focus, instead of the Diopter Adjustment Ring.

Not Shown in Diagram:

Detachable Light Guide Cable: Standard 1.8m cable shipped with endoscope.

Light Guide Sleeve: Adapts the Light Guide Cable to make it compatible with different light sources.

BF-2.8*, BF-2.1 and BF-1.5 Slide-On® EndoSheath® Technology

The **BF-2.8***, **BF-2.1** and **BF-1.5 Slide-On® EndoSheath® Technology** (shown in Figure 3-3 below) is a sterile, disposable barrier for the Cogentix Medical **BRS-4000** Flexible Bronchoscope. The Sheath isolates the Bronchoscope from contact with patient fluid and material during the procedure.

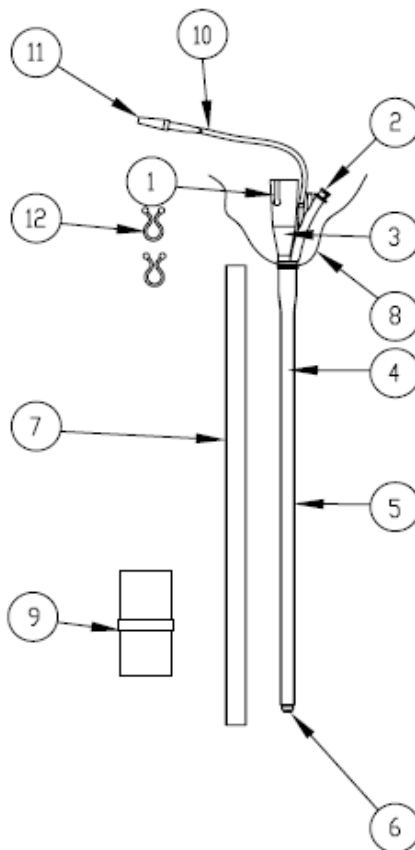

Figure 3-3: BF-2.8*, BF-2.1 and BF-1.5 Slide-On® EndoSheath® Technology

(*See Page 2)

BF-2.8*, BF-2.1 and BF-1.5 Sheath Components

1. **Slot for Locking Knob:** The Bronchoscope's Locking Knob slides into this slot to secure the Sheath to the Bronchoscope.
2. **Accessory Port with Removable Seal:** Allows fluid injection and the passage of accessories during endoscopic procedures. **NOTE:** The **BF-1.5** Diagnostic Sheath is **not** indicated for accessory passage; it supports fluid aspiration and suction only. The removable seal allows a Luer-Lock syringe to be attached for fluid instillation and withdrawal.
3. **EndoSheath[®] Connector:** Secures the Sheath to the Bronchoscope.
4. **Working Channel:** Running the length of the Sheath, this impermeable channel allows maximum instillation and evacuation, as well as the passage of accessory devices. **NOTE:** The **BF-1.5** Diagnostic Sheath is **not** indicated for accessory passage; it supports fluid aspiration and suction only. The **BF-2.8*** (*see Page 2) and **BF-2.1** Therapeutic Sheaths have 2.8mm and 2.1mm Working Channels respectively and can accommodate accessory instruments.
5. **Insertion Tube Barrier:** A flexible, elastomeric sleeve that creates a barrier over the Bronchoscope's Insertion Tube.
6. **Sheath Window:** An optically clear window that covers the Distal Tip of the Bronchoscope.
7. **Protector Tube:** Protects the Sheath from external damage during shipping, storage, and Sheath loading.
8. **Control Body Cover:** Protects the Bronchoscope's Control Body from becoming contaminated with patient material during the procedure.
9. **Drape Bag:** A polyethylene bag with an adhesive strip that protects the Installation Stand from contamination, collects post-procedural bodily fluids, and is designed to contain the used Sheath for disposal.
10. **Suction Tube:** Provides access for suction to the Distal Tip.
11. **Suction Tube Connector:** A standard suction fitting allows a suction tube to be connected here.
12. **Control Body Cover Clips (2):** The clips secure the Control Body Cover to the Light Guide Cable and Suction Tube.

(*See Page 2)

BF-0 Slide-On® EndoSheath® Technology

The **BF-0 Slide-On® EndoSheath® Technology** is also a sterile, disposable barrier for the Cogentix Medical **BRS-4000** Flexible Bronchoscope. The Sheath isolates the Bronchoscope from contact with patient fluid and material during the procedure (does not support fluid instillation, suction, or accessory tool passage).

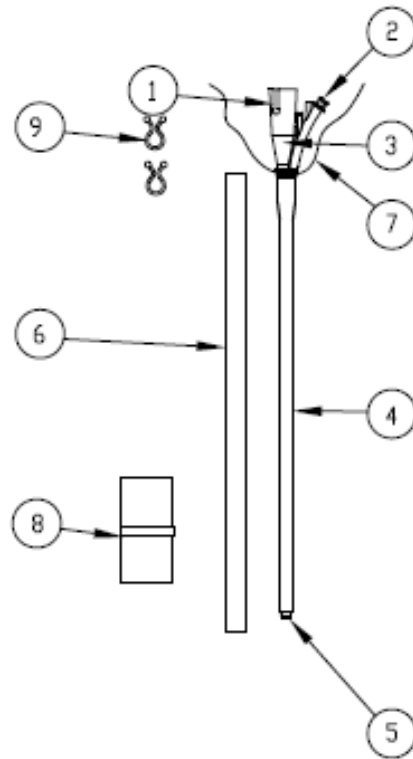

Figure 3-4: BF-0 Slide-On® EndoSheath® Technology

BF-0 Sheath Components

1. **Slot for Locking Knob:** The Bronchoscope's Locking Knob slides into this slot to secure the Sheath to the Bronchoscope.
2. **Sealed Accessory Port:** On the **BF-0 Slide-On® EndoSheath® Technology**, the Accessory Port is sealed because standard accessory tools cannot be passed through the Sheath.
3. **EndoSheath® Connector:** Secures the Sheath to the Bronchoscope.

4. **Insertion Tube Barrier:** A flexible, elastomeric sleeve that creates a barrier over the Bronchoscope's Insertion Tube.
5. **Sheath Window:** An optically clear window that covers the Distal Tip of the Bronchoscope.
6. **Protector Tube:** Protects the Sheath from external damage during shipping, storage, and Sheath loading.
7. **Control Body Cover:** Protects the Bronchoscope's Control Body from becoming contaminated with patient material during the procedure.
8. **Drape Bag:** A polyethylene bag with an adhesive strip that protects the Installation Stand from contamination, collects post-procedural bodily fluids, and is designed to contain the used Sheath for disposal.
9. **Control Body Cover Clips (2):** The clips secure the Control Body Cover to the Light Guide Cable and Suction Tube.

Installation Stand

CAUTION Installation and removal of the **Slide-On® EndoSheath® Technology** onto and from the Bronchoscope should always be performed using the Installation Stand. Failure to do so may cause installation difficulty and/or equipment damage.

Refer to Figure 3-5 below and the Installation Stand's Instructions for Use for information on the correct preparation and use of the stand.

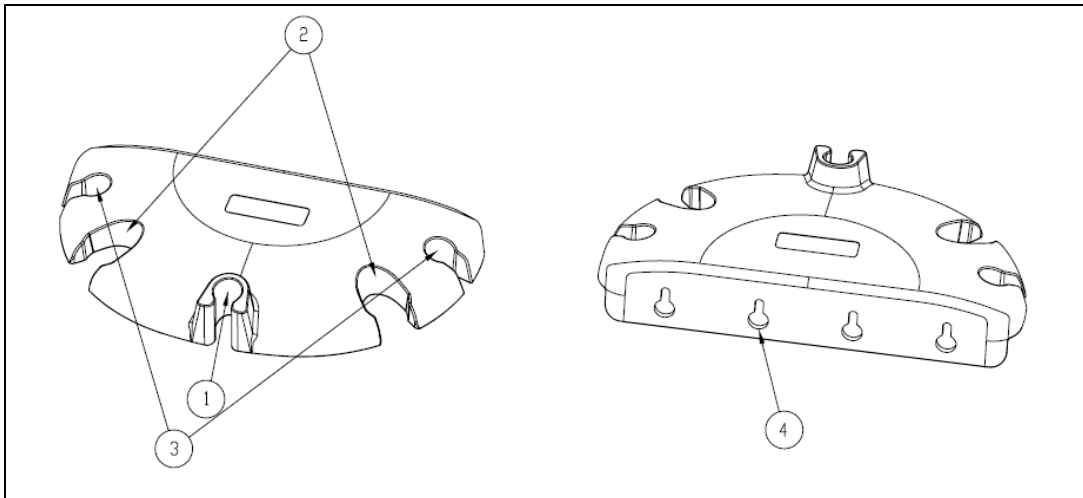

Figure 3-5: Installation Stand

1. **EndoSheath® Slot/Holder:** The slot that securely holds the EndoSheath® Connector, which is designed to fit with its Accessory Port facing out.

Endoscope and Accessories

2. **Endoscope Storage Slots:** Post-procedure slots for hanging endoscopes. (Not intended for long-term storage unless the Installation Stand is wall-mounted.)
3. **Cable Storage Slots:** For securing the Light Guide Cable when the endoscope is not in use (if using the BLS-1000 light source, these slots are not needed).
4. **Wall-Mounting Bracket/Holes:** For mounting on a wall or inside a cabinet for storage purposes.

Accessories

WARNING

Do not use any accessories that are not in compliance with the equivalent safety requirements of this equipment. Doing so may reduce the operational safety of the system and could cause patient and/or user injury. For all accessories, confirm that the safety certifications have been performed in accordance with the appropriate standard (IEC 60601-1 and/or IEC 60601-1-1).

Use of accessories not specified in this manual or sold by Cogentix Medical may result in increased electromagnetic emissions or decreased immunity of the equipment or system.

BLS-1000 Battery Powered Light Source

An LED light source that allows for illumination without a cable. Refer to Chapter 5, **Preparation, Inspection and Operation** for proper set-up and operation information. The **BRS-4000** Bronchoscope is designed to be used with the **BLS-1000** Battery Powered Light Source.

Light Guide Cables

The **BRS-4000** Bronchoscope is designed to operate effectively with Cogentix Medical Light Guide Cables. The Light Post on the **BRS-4000** will accept light guide cables made by other manufacturers with an ACMI-style connection/adaptor.

Other Light Sources

The **BRS-4000** Bronchoscope is designed to be compatible with various light sources. To ensure proper connection to the selected light source, be sure to use an appropriate light guide adapter which is securely attached to the Light Guide Cable Connector. Refer to Figure 3-6 for a complete list and drawings of the available Light Guide Sleeves.

Add-On Camera Systems

The **BRS-4000** Bronchoscope features a "rigid" style eyepiece that is compatible with most manufacturers' add-on camera systems. Ensure that the selected camera system's coupler is compatible with a "rigid" style eyepiece. If it is not, please contact Cogentix Medical for assistance.

Leak Testing

The **BRS-4000** Bronchoscope may only be leak tested with a Cogentix Medical Endoscope Leak Tester.

Reprocessing

The **BRS-4000** Bronchoscope may be reprocessed by a variety of methods. Refer to Chapter 6, **Reprocessing** for the accessories that will be used when reprocessing the endoscope. Contact Cogentix Medical Customer Service for advice on compatibility issues.

Therapeutic/Diagnostic Accessories

The **BF-2.8*** and **BF-2.1 Slide-On® EndoSheath® Technology** features a 2.8mm and 2.1mm working channel, respectively. Bronchoscopy tools and accessories that are compatible with a 2.8mm and/or 2.1mm channel should be compatible with this system. For further information regarding tools and accessories, please contact your local distributor or Cogentix Medical Customer Service Department.

CAUTION The **BF-1.5** and **BF-0 Diagnostic Slide-On® EndoSheath® Technologies** do not support accessory tool passage. Attempting to insert an accessory or tool may damage the Sheath.

(* Available in select markets only)

Light Source Adapters

A number of different Light Guide Sleeves are available to adapt Cogentix Medical endoscopes for use with other manufacturers' light sources. Figure 3-6 shows diagrams of all compatible adapters, lists the light sources with which they are compatible, and gives the Cogentix Medical Catalog Number for each one.

CAUTION Using an incorrect or incompatible adapter could result in impaired operation and viewing, and could cause damage to the endoscope, Light Guide Cable and/or light source.



LIGHT GUIDE SLEEVE DIAGRAM	CATALOG NUMBER & COMPATIBLE LIGHT SOURCES
	<p><u>06-6019</u>: Cogentix Medical HLS-1500 / XLS-3000, Circon and ACMI Light Sources</p>
	<p><u>06-6009</u>: Cogentix Medical LS-150 and Pentax Light Sources</p>
	<p><u>06-6044</u>: Olympus Light Sources</p>
	<p><u>06-6020</u>: Smith & Nephew, Gyrus, and Richard Wolf Light Sources</p>
	<p><u>06-6029</u>: Machida Light Sources</p>
	<p><u>06-6023</u>: Karl Storz Light Sources</p>

Figure 3-6: Light Source Adapters (Light Guide Sleeves)

4 Installing and Removing the Slide-On[®] EndoSheath[®] Technology

CAUTION

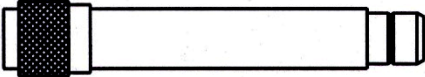
Installation and removal of the **Slide-On[®] EndoSheath[®] Technology** onto and from the Bronchoscope should always be performed with the Installation Stand. **Failure to utilize the installation stand for setup and preparation may lead to difficulty in installation and ultimately equipment damage.**

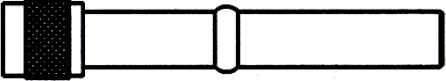
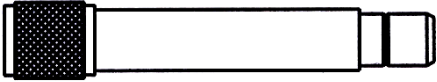
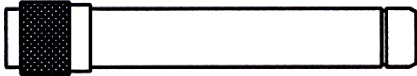
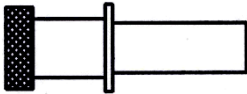
Ensure that the endoscope is clean and dry prior to installing the **Slide-On[®] EndoSheath[®] Technology**. Any moisture on the endoscope prior to installation may result in difficulty removing the endoscope from the **Slide-On[®] EndoSheath[®] Technology** after the procedure.

Wear appropriate protective gear when using the **Slide-On[®] EndoSheath[®] Technology** and bronchoscope, including gown, gloves, and face and eye shields. To maintain a sterile field during installation, it is recommended that users wear two (2) pairs of sterile gloves.

Install the Slide-On[®] EndoSheath[®] Technology

WARNING

Before installing the Sheath, carefully inspect the endoscope's Insertion Tube for any damage or defects. If any irregularities are found, do not use the endoscope. Using a damaged or defective endoscope could damage the Sheath, cause further damage to the endoscope itself, and/or cause patient or user injury.

The **Slide-On[®] EndoSheath[®] Technology** is supplied sterile, and is intended for a single use only. **Do not reuse** or attempt to re-sterilize the Sheath, as it could become damaged, which could in turn cause damage to the endoscope and/or present an infection-control risk to the patient and/or user.

CAUTION

Do not expose the interior or exterior of the sheath to alcohol or other cleaning agents prior to use.

The bronchoscope and sheath do not have any user serviceable parts. Do not attempt any repairs. If malfunction occurs, refer to the Troubleshooting section or call Cogentix Medical for assistance.

Exercise caution when using the Bronchoscope and Sheath in the presence of flammable anesthetics or oxygen.



NOTE: Refer to **Instructions for Use** for BF-2.8*, BF-2.1, BF-1.5 and BF-0 Sheaths.

Prepare the Endoscope and Sheath

1. Before installing the Sheath, clean the endoscope's eyepiece and the lens on its Distal Tip with an alcohol prep pad. **Do not** use abrasive materials to clean the endoscope's eyepiece or lens. Doing so could damage these components and impair the endoscope's imaging capability.
2. Check the EndoSheath® disposable packaging pouch for defects or damage.
3. Put on (2) two pairs of sterile gloves; open the Sheath's package carefully.
4. Remove the plastic Drape Bag, open it, remove adhesive strip backing and secure it to the Installation Stand.
5. Remove the Sheath from the package (the Sheath should remain in the Protector Tube during installation).
6. Remove the two Control Body Cover Clips from the package and place them on a clean surface.
7. Place the Sheath into the Installation Stand with the Accessory Port facing toward you. Note: the Sheath fits in the Stand in only one direction.
8. Fold back the Control Body Cover to expose the top opening of the EndoSheath® connector.

Insert the Endoscope Into the Sheath

9. Make sure that the Distal Bending section of the endoscope is straight.
10. Hold the Bronchoscope vertically above the Sheath. Align the Bronchoscope's D-shaped Insertion Tube with the D-shaped opening of the EndoSheath® Connector – **the flat portion of the Insertion Tube should face toward the Sheath's Accessory Port (toward you).**
11. Gently slide the Insertion Tube into the Sheath, keeping the Insertion Tube as straight as possible aligned with the shape of the insertion hole. Do not rotate Insertion Tube during insertion (this will cause resistance).

CAUTION

When inserting the endoscope into the Sheath, avoid excessive bending of the Insertion Tube, as it could damage the Sheath and/or the endoscope.

(*See Page 2)

DO NOT apply excessive force to install the Sheath onto the endoscope if insertion is found to be difficult. If you experience difficulty installing the Sheath, refer to Chapter 8, **Troubleshooting**. If the recommended actions given there do not ease endoscope insertion, call your local distributor or Cogentix Medical Customer Service at 866 258-2182 (toll free in U.S.) or (+1) 952-426-6189 (international) for further instruction.

Note: It is **extremely** important to maintain the alignment between the flat portion of the Insertion Tube with the biopsy port on the EndoSheath® Connector during installation and removal. If there is resistance in loading the endoscope into the Sheath, remove the protective tube to verify proper alignment of the Sheath channel. If the channel is misaligned, straighten the channel and continue scope insertion.

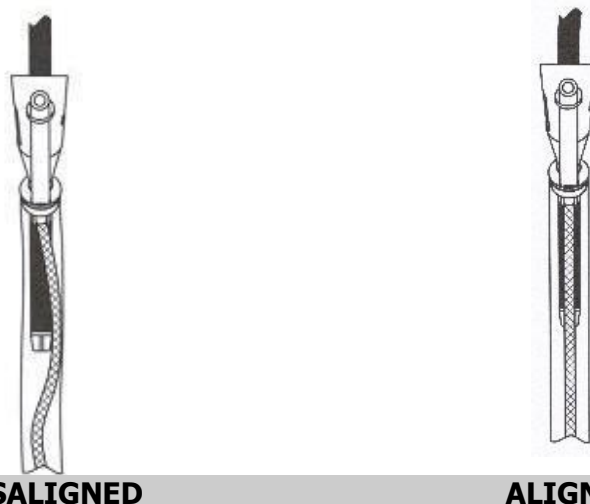

Figure 4-1: Sheath Alignment

12. Rotate the endoscope's Locking Knob so that it is in a vertical position.
13. Align the Locking Knob on the bronchoscope with the vertical slot on the EndoSheath® Connector, and continue to slide the endoscope into the Sheath until the Locking Knob is fully seated at the base of the slot.
14. Rotate the Locking Knob on the scope to the horizontal position. This will ensure a secure fit between the EndoSheath® Connector and the endoscope.

Connect Suction Tubing

15. Connect the Suction Tubing to the endoscope's Pinch Valve mechanism (either valve can be used) by pressing the button and stretching the tubing against the tubing slot. When the tubing is seated in the valve, release the button. This will squeeze the suction channel closed.

16. Connect the Suction Tubing to the external suction source.
17. Remove outer pair of gloves.

Complete System Assembly

18. Pull the Sheath's Control Body Cover up over the endoscope's Control Body.
19. Align the Eyepiece opening of the Control Body Cover with the endoscope's Eyepiece and pull down on the cover so that the eyepiece extends through the opening.
20. Secure the Control Body Cover and Suction Tubing to the Light Guide Cable using the Cover Clips. If using the **BLS-1000** Battery Powered Light Source, twist the Control Body Cover and fold over two times (2x); then use the Control Body Clips to secure.
21. Press the Pinch Valve to turn on and off; confirm that it operates properly.
22. Carefully remove the Sheath from the protective tube and discard. **Do not** re-install the protective tube onto the Sheath, or damage to the Sheath may result.
23. Visually inspect the window of the Sheath and confirm that the endoscope's Distal Tip is flush with the Sheath's window. If a gap is observed between the Distal Tip and the Sheath's window, move the Angulation Lever up and down to articulate the Distal Bending Section. This process should properly seat the Sheath. **NOTE:** if Sheath window is not fully seated, the image may be impaired.

CAUTION Do not articulate bending section while the protective tube is on.

24. Turn on the external suction source. Verify systems are functioning properly.
25. The system is ready for use.

Observe the Endoscopic Image

The Sheath's window should now be in direct contact with the Insertion Tube's Distal Tip. To confirm this, view an endoscopic image with a light source on; there should be no glare.

If a gap is observed between the Distal Tip and the Sheath's window, or if glare is observed in the endoscopic image, move the Angulation Lever up and down several times to articulate the Distal Bending Section (this should properly seat the Sheath). In some cases, it may be necessary to hold the edge of the optical window (**while wearing gloves**) and move it gently to fully seat the Sheath.

Remove the Slide-On® EndoSheath® Technology

When the endoscopic procedure is complete, the **Slide-On® EndoSheath® Technology** must be removed and disposed of properly to eliminate the possibility of infection-control risks.

CAUTION

Wear appropriate personal protective equipment when removing the sheath from the endoscope, to prevent the possibility of infection from contact with patient material. **Cogentix Medical strongly recommends that a double set of gloves be worn for this procedure.**

Always use the Installation Stand to remove the endoscope from the Sheath. Attempting to remove the endoscope without using the Installation Stand could cause damage to the endoscope.

1. Double-glove and assure the Drape Bag is completely covering the Installation Stand.
2. Insert the Bronchoscope into the draped Installation Stand (Accessory Port facing you). The contaminated, sheathed Insertion Tube must be contained within the Drape Bag to capture and contain any patient material and/or fluids.
3. Disconnect the Suction Tubing from the suction source.
4. Remove the Control Body Cover Clips and discard them in the Drape Bag. Keeping your hands on the outside of the contaminated Control Body Cover, pull the Cover forward and down off of the endoscope.
5. Remove the outer set of gloves. **Do not** handle the Bronchoscope's Control Body with contaminated gloves.
6. Remove the Suction Tubing from the Pinch Valve mechanism by pressing the button, and pulling the tubing free.
7. Rotate the Locking Knob into the vertical position so that it is aligned with the slot on the EndoSheath® Connector.
8. Articulate the Distal Bending Section of the endoscope into the straight/neutral position.
9. Ensure the working channel is not wrapped around the insertion tube by straightening the channel with gloved fingers.
10. Hold the endoscope's Control Body in one hand. Slowly and gently withdraw the scope from the Sheath. Note: If resistance is encountered, use the hanging drape as a barrier between your fingers and the Sheath

Installing and Removing the Slide-On® EndoSheath® Technology

and gently grasp the Sheath's window. Then slowly and gently continue to withdraw the scope from the Sheath.

CAUTION Do not rotate the endoscope when removing it from the sheath. Doing so can damage the Insertion Tube.

If you experience difficulty removing the endoscope from the Sheath, **do not** use excessive force in trying to remove it. Refer to Chapter 8, **Troubleshooting**, for further instructions.

11. Place the endoscope in a non-contaminated area.
12. Inspect the Insertion Tube and Distal Tip, and confirm that these areas are dry. If moisture is observed, there may have been a leak into the Sheath during the procedure, provided that the endoscope was dry when the Sheath was attached. In this case, the endoscope must be high-level disinfected or sterilized following the instructions given in Chapter 6, **Reprocessing**.
13. Collect the contaminated Sheath in the Drape Bag and remove from the Installation Stand. Carefully discard the contaminated Drape Bag per hospital/facility policy.
14. Proceed to the Recommended Cleaning Procedure detailed in Chapter 6, **Reprocessing**, to prepare the endoscope for the next procedure.

5 Preparation, Inspection and Operation

WARNING

If an abnormality is detected during endoscope preparation, do not use the equipment; refer to the tables in Chapter 8, **Troubleshooting**. If the problem cannot be solved using the information found in that chapter, contact your regional distributor or Cogentix Medical Customer Service.

The **Slide-On® EndoSheath® Technology** is shipped sterile and intended for a single use only; do not reuse it. When the procedure is complete, remove the Sheath from the endoscope and dispose of it. Reusing the Sheath can damage it, and in turn cause endoscope damage. In addition, a reused Sheath presents a marked infection-control risk to the next patient.

When using the **Slide-On® EndoSheath® Technology** with the endoscope, refer to its Instruction for Use (shipped with the system). These instructions will provide complete details on preparing, installing and removing the disposable sheath.

During the procedure, the temperature at the Distal Tip of the endoscope may exceed 41°C (106°F) due to the intense endoscopic illumination. Surface temperatures over 41°C (106°F) may cause mucosal burns. Always use the minimum level of illumination necessary for adequate viewing. Whenever possible, avoid close stationary viewing and do not leave the Distal Tip of the endoscope in close proximity to mucous membranes for a long time.

Preparation and Inspection

Follow the inspection steps listed below before connecting any equipment or using the system. Do not use the equipment if abnormalities are detected:

1. Check the Insertion Tube for holes, superficial cuts or abrasions.
2. Lightly run your fingertips over the entire length of the Insertion Tube to confirm that it is smooth and does not exhibit looseness or bagging.

CAUTION

Do not apply excessive pressure when moving the Angulation Lever. Doing so could damage the internal components of the insertion tube.

Preparation, Inspection and Operation

3. Check the distal end of the Sheath's Working Channel for any sharp edges, being careful to minimize contact with the clear window.
4. Check for full Distal Tip deflection by moving the Angulation Lever up and down.
5. Clean the Objective Lens on the Distal Tip with an alcohol prep pad.

CAUTION

Do not use abrasive materials to clean the Objective Lens. Doing so could damage the Objective Lens and impair the endoscope's imaging capability.

Avoid applying excessive pressure when using the Angulation Lever. Doing so can damage the angulation mechanism.

6. Ensure that the proper Light Guide Adapter is securely connected to the Light Guide Cable.
7. Securely insert the Light Guide Cable into the light source.
8. Look through the Eyepiece and rotate the Diopter Adjustment Ring until the fiber pattern is clearly focused.
9. When using a video camera, still photography system, or teaching attachment with the endoscope, make sure that the white dot on the Control Body is aligned with the white dot on the Diopter Adjustment Ring.
10. Confirm that the suction source is connected to the Sheath's Suction Tube. Turn on the Suction Pump, press the Suction Button, and confirm that there is suction at the Distal Tip. If the tubing is not seated properly in the Pinch Valve, suction will not be available.



NOTE: When using the **BF-2.8*** or **BF-2.1 Sheath** with suction tubing, connecting the external suction source to the Sheath's Suction Tube will allow for suction while an accessory is in place, inserted into or attached to the Accessory Port.

WARNING

If using the bronchoscope with an endotracheal intubation tube (ETT) to ease intubation, do not load an undersized intubation tube over the insertion tube of the bronchoscope and sheath barrier during procedure set-up, as the insertion tube may become stuck within the ETT and result in difficult removal. Ensure that the ETT moves easily over the insertion tube of the bronchoscope before starting the procedure. Lubricant may be used to ease movement within the ETT as long as it is the appropriate size.

(*See Page 2)

CAUTION

Avoid excessive bending or twisting of the endoscope's Insertion Tube, particularly at the distal end. While the tube is designed to bend, excessive pressure can damage the fiber bundles and internal components.

Excessive angulation or excessive pressure placed on the Angulation Lever may cause equipment damage. Do not exert force to move the lever beyond its natural limits.

Endoscope Operation with BLS-1000 Battery Powered Light Source

1. Prior to use, the **BLS-1000** should be reprocessed. Please refer to **BLS-1000** Battery Powered Light Source User's Manual for proper Reprocessing Procedures and compatibilities.
2. If necessary, insert charged or new batteries into the **BLS-1000**.
3. Verify the **BLS-1000** is in proper working condition before attaching to the endoscope by examining the outer cover for damage, secure cover fit, and with Light Source powered OFF, verify that the window over the bulb is clear and not obstructed.
4. Thread the **BLS-1000** onto the endoscope Light Post. Verify that the Light Source is OFF until needed. OR, if using the detachable Light Guide Cable, ensure that the proper Light Guide Sleeve is securely threaded onto the Light Guide Cable.
5. Just prior to the procedure, rotate the outer body of the **BLS-1000** to the ON position.

CAUTION

Point the light-emitting area of the Light Source **away from eyes** before turning on the light.

6. Turn on the **BLS-1000**. OR, if using the detachable Light Guide Cable, insert Light Guide Cable into the light source (snap the Light Guide Cable in securely) and turn on the light source.
7. Verify light emission by viewing through the eyepiece. While viewing through the eyepiece, rotate the Diopter Adjustment Ring clockwise or counterclockwise until the fiber pattern in the image field is clearly focused.
8. If using a video camera, still photography system, or teaching attachment with the endoscope, be sure the white dot on the Control Body is aligned with the white dot on the Diopter Adjustment Ring.

WARNING

Do not handle the BLS-1000 with contaminated gloves. If the **BLS-1000** becomes contaminated, it must be reprocessed per the protocols in the **BLS-1000** Battery Powered Light Source User's Manual.

Preparation, Inspection and Operation

9. Hold the endoscope so that the control body fits comfortably in your hand, allowing easy manipulation of the Angulation Lever. The other hand is free to manipulate the Insertion Tube of the endoscope.

CAUTION Excessive angulation or excessive pressure on the Angulation lever may cause equipment damage. Do not exert force to move the lever beyond its natural limits.

10. Prepare the patient using normally acceptable clinical practice prior to endoscope insertion.
11. Lubricate the outside of the Sheath before inserting the endoscope into the patient. Cogentix Medical recommends that the Sheath be lubricated with water or a water-based lubricant just prior to insertion.
12. Introduce the sheathed endoscope into the patient using normally acceptable clinical practice. Operate the Angulation Lever as necessary for advancement and observation.
13. When using the system through an endotracheal tube, it is extremely important that alignment between the tube and the bending section of the endoscope be maintained.
14. When the procedure is complete, withdraw the endoscope under direct visualization without holding the Angulation Lever. This will allow the Distal Bending Section to move freely during withdrawal.
15. When the procedure is finished, rotate the outer body of the **BLS-1000** to the OFF position.

Endoscope Operation – Other Light Sources

1. Hold the endoscope so that the Control Body fits comfortably in your hand, allowing you to manipulate the Angulation Lever. The other hand is free to manipulate the Insertion Tube.
2. Turn the light source on. Adjust the brightness to the desired level using the light source's brightness adjustment controls.
3. Prepare the patient using normally acceptable clinical practice prior to endoscope insertion.
4. If the endoscope will be inserted into the patient's mouth, first place a bite block into the patient's mouth to prevent bite damage.
5. Lubricate the outside of the Sheath before inserting the endoscope into the patient. Cogentix Medical recommends that the Sheath be lubricated with water or a water-based lubricant.

6. Introduce the sheathed endoscope into the patient using normally acceptable clinical practice. Operate the Angulation Lever as necessary for advancement and observation.
7. When the procedure is completed, withdraw the endoscope under direct visualization without holding the Angulation Lever. This will allow the Distal Bending Section to move freely during withdrawal.

Suction

Press the Suction Button on the endoscope's Control Body to activate suction. Release the Button to stop suction.



NOTE: Recommended Suction Pressure Settings: 160 – 180 mmHg (6.3 – 7.1 inHg or 3.1 – 3.5 psi) for optimal levels, increasing in slight increments if stronger suction power is needed.

Depending on the gauge design, the suction pressure level may be displayed as either a negative (true) or positive number. Due to differences in suction equipment and accessories, suction settings may need to be adjusted to meet specific procedural needs. However, excessive suction pressure settings may collapse tubing, which will impair suction performance. The **Slide-On® EndoSheath® Technology** is validated to an upper limit of 580 mmHg (22.8 inHg or 11.2 psi).

Instilling Fluids

To inject anesthesia, saline or other fluids, attach a syringe to the Sheath's Accessory Port. When using the **BF-2.8*** or **BF-2.1 Slide-On® EndoSheath® Technology**, the syringe tip may be inserted directly into the Accessory Port Seal's opening.

CAUTION

Make sure that the syringe is seated properly and straight in the Sheath's Accessory Port. Otherwise, the seal may be compromised and fluid may not flow smoothly into the Working Channel.

Inserting Accessories

CAUTION

Accessories may only be inserted when using the **BF-2.8*** or **BF-2.1 Slide-On® EndoSheath® Technology**. The **BF-1.5 Diagnostic Sheath** and **BF-0 Diagnostic Sheaths** do not support accessory tool passage.

Before inserting an accessory into the Sheath, confirm that it is compatible with a 2.8mm or 2.1mm diameter Working Channel. If the accessory is too large, it will damage the Sheath and may compromise the integrity of the barrier.*

(*See Page 2)

Do not continue advancing an accessory if excessive resistance is encountered, and do not use excessive force to try and advance it. The use of excessive force may result in damage to the Sheath and/or the endoscope.

1. Before inserting an accessory, straighten the endoscope's Distal Bending Section (Insertion Tube), and look through the Eyepiece to confirm that there is a clear lumen.
2. Insert the tip of the accessory through the Sheath's Accessory Port. Using straight, steady strokes, pass the accessory through the Working Channel until the tip of the accessory is visible when looking through the Eyepiece.
3. If resistance is encountered while inserting the accessory, withdraw the accessory, straighten the endoscope's Distal Bending Section, and attempt to insert the accessory again. If resistance is still felt, confirm that the accessory's diameter is compatible with the size of the Working Channel. Refer to Chapter 8, **Troubleshooting**, for additional suggestions.

Electrosurgical Devices / Accessories

The **BRS-4000** Flexible Bronchoscope and **Slide-On® EndoSheath® Technology** may be used with high-frequency (HF) electrosurgical devices. Operators utilizing HF devices and accessories should follow all manufacturer and facility guidelines for proper and safe use. Refer to the user manuals of all HF devices being used in the procedure, and closely follow all indications, instructions, and safety precautions.

WARNING

Before using any electrosurgical devices for high frequency cauterization, users should be thoroughly familiar with all guidelines, safety precautions, and proper use of the equipment. Follow all manufacturer instructions on proper equipment preparation and use. Accessories should be inspected for damage before and after each procedure.

Before electrosurgery, inspect the endoscope for any physical damage to surfaces and components. If damage is discovered, discontinue use and contact Cogentix Medical for repair. Continued use of damaged equipment during electrosurgery may lead to equipment damage and/or patient injury.

A thorough understanding of the principles and techniques involved in electrosurgical procedures is essential to avoid shock and burn hazards to both patient and medical personnel and prevent damage to the device and other medical instruments. Ensure that insulation or grounding is not compromised.

Do not immerse electrosurgical instruments in liquids unless the instruments are specifically designed and labeled to function in liquids.

Always confirm that the electrode section of the electrosurgical accessory is an appropriate distance from the Distal Tip of the endoscope and that the electrode is clearly in view.

If the electrode is in close proximity to the Distal Tip or still within the **Slide-On® EndoSheath® Technology** during use, the endoscope and/or **Slide-On® EndoSheath® Technology** may be damaged and patient injury may occur.

WARNING

Set the high-frequency (peak) voltage level of the electrosurgical unit no higher than the voltages given below for the respective operating modes:

- CUT: 1,300 V_p
- COAG: 3,000 V_p
- SPRAY: 3,950 V_p

Always utilize the lowest output setting necessary on the Electrosurgical Unit. This reduces the potential for patient injury or equipment damage.

When the recommended voltages shown in the instructions for electrosurgical accessories differ from normally acceptable limits, always use the lowest recommended voltage.

Exercise caution when supplying oxygen during electrosurgery, or performing electrosurgery in the presence of combustible gases. There is the potential for combustion during cauterization.

Cogentix Medical recommends the use of isolated electrosurgical accessories. Use of non-isolated accessories may result in operator injury.

To best determine the necessary minimum output, operators should conduct basic tests before electrosurgery according to the User's Manual for the electrosurgical unit.

Laser Devices / Accessories

WARNING

Do not use a damaged laser fiber accessory. Utilizing a probe with a damaged cover or distal end may result in patient injury and/or equipment damage.

Always confirm that the Distal Tip of the laser fiber accessory is an appropriate distance from the Distal Tip of the endoscope, and that the laser fiber tip is clearly in view. If the Distal Tip of the accessory is in close proximity to the endoscope's Distal Tip or still within the **Slide-On® EndoSheath® Technology** during use, the endoscope and/or **Slide-On® EndoSheath® Technology** may be damaged and patient injury may occur.

Exercise caution when supplying oxygen during laser surgery, or when performing laser surgery in the presence of combustible gases. There is the potential for combustion during cauterization.

Follow all manufacturer instructions on proper equipment preparation and use. Accessories should be inspected for damage before and after each procedure.

CAUTION

Before inserting or removing a laser fiber accessory, ensure that the endoscope's Distal Bending Section is in the neutral position and straight. If the Distal Bending Section is articulated, there is a risk of damaging the Instrument Channel of the **Slide-On® EndoSheath® Technology**.

6 Reprocessing

The **BRS-4000 Flexible Bronchoscope** works in tandem with the **Slide-On® EndoSheath® Technology**. The **Slide-On® EndoSheath® Technology** is a sterile, disposable protective covering which limits the need for elaborate chemical disinfection or EtO sterilization procedures after every endoscopy procedure. The complete system enables the user to implement a fast and effective method of reprocessing the endoscope, and benefits both user and patient by providing an insertion tube covered with a sterile sheath for every procedure. For cleaning/disinfection procedures when using the **EndoSheath® Technology**, see **Cleaning After Slide-On® EndoSheath® Technology Use** on page 39.

WARNING

The endoscope must be properly reprocessed by cleaning, disinfection or sterilization, before its first use and after each subsequent use according to the protocols in this section. Using an endoscope in a procedure that has not been properly reprocessed presents an acute infection-control risk to both the patient and medical personnel performing or assisting in the procedure.

CAUTION

Some methods of disinfection and sterilization may be harmful to the endoscope and exposure to them could result in extensive equipment damage. Please contact Cogentix Medical Customer Service to verify the compatibility of a cleaning method not listed in this manual and/or a complete list of functionally compatible agents.

Clean the endoscope immediately after use in a procedure. Failure to do so may allow patient debris to harden on the endoscope's external surfaces, which can become difficult to remove and could inhibit subsequent disinfection/sterilization processes.

Do not use an endoscope that has been determined to have a leak, and do not immerse such an endoscope in any fluids. Fluid entry into the endoscope can cause equipment damage and render the endoscope unfit for patient use.

Always wear appropriate personal protective equipment when reprocessing the endoscope or any of its components. Appropriate protective equipment includes items such as a gown, gloves, and face and eye shields.

Complete and thorough reprocessing of the endoscope is the only way to ensure that a “patient-ready” endoscope is used in all patient procedures. Closely adhere to the reprocessing instructions given in this chapter.

Reprocessing Steps

The endoscope reprocessing procedure is made up of a series of discrete steps, each of which is essential to successful reprocessing. The steps are listed below in their proper order, and the complete instructions for each step are given in greater detail in this chapter.

- **Leak Testing** – The reprocessing procedure requires exposing the endoscope’s surface to and immersing the endoscope itself in fluids. If there is a leak in any part of the endoscope, the vulnerable internal components of the endoscope will likely be damaged by fluid invasion. Before cleaning, disinfecting and/or sterilizing the endoscope, it is essential to perform a leak test to ensure the interior of the endoscope is resistant to fluids.
- **Cleaning** – Visible debris is removed from the surface of the endoscope in this procedure, which uses water and an instrument-grade detergent. When the **Slide-On® EndoSheath® Technology** is used and inspection after the procedure confirms that the Sheath was not compromised, surface cleaning and intermediate level disinfection of the endoscope should be sufficient to prepare it for the next procedure.
- **Intermediate-Level Disinfection** – After use with an EndoSheath® System and proper cleaning, the endoscope should undergo intermediate-level disinfection. For the complete routine, see **Cleaning After Slide-On® EndoSheath® Technology Use** on page 39.
- **High-Level Disinfection** – If the user suspects the endoscope has become contaminated, it will be necessary to immerse the endoscope in a high-level disinfectant.
- **Sterilization** – In addition to high-level disinfection, the endoscope may be sterilized using ethylene oxide (EtO) gas. Following sterilization, the endoscope must be thoroughly aerated to ensure that all EtO gas residues have been removed. The endoscope may also be sterilized using a validated STERRAD® or STERIS® system. Refer to the STERRAD®/STERIS® section in this chapter.

Leak Testing

The **BRS-4000** Flexible Bronchoscope must be evaluated for possible leaks in the Control Body and/or Insertion Tube before immersion in any fluids. The Leak Tester accessory should be used for this test. (Cogentix Medical Leak Tester is required.) Follow the steps given below.

WARNING

It is essential that gloves be worn when performing the leak test procedure, in case the endoscope's Insertion Tube has been contaminated and requires further disinfection or sterilization. An endoscope in this condition can present an infection-control risk to the person(s) reprocessing the endoscope.

Attach the Leak Tester to the Endoscope

Connect the Leak Tester to the endoscope's Vent Valve (see Figure 6-1). Align the slot on the Leak Tester's connector with the pin on the Vent Valve, then push down and rotate the connector clockwise until it locks.

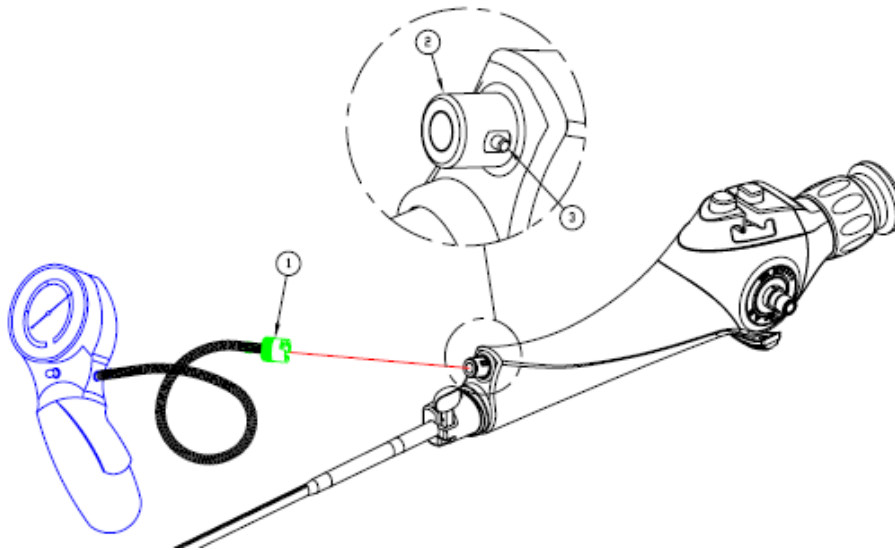

Figure 6-1: Leak Tester Connection

Leak Test Connection Components:

1. Leak Test Connector
2. Vent Valve
3. Alignment Pin (align with slot in connector)

Pressurize the Endoscope

1. Make sure that the Leak Tester's Pressure-Relief Valve is closed by moving the button to the "out" position.
2. Pump the hand bulb of the Leak Tester until the pressure gauge's needle reaches **the green zone** (signifying the desired pressure). Due to the size of the internal space of the endoscope, 2-3 pumps of the hand bulb may be required to pressurize the entire chamber. After the first pump, the needle may drop out of the green zone and reach a stable position in the white zone. Continue with additional pumps until the needle no longer falls back into the white zone.

Reprocessing

CAUTION

Do not over-pressurize the interior of the endoscope (do not allow the needle to go above the green area on the gauge). Over-pressurizing the interior of the endoscope can damage the light-transmission and/or optical system components.

3. Maintain the pressure for ten (10) seconds, observing the position of the needle on the pressure gauge. If the pressure decreases, the Leak Tester/Endoscope connection may be loose or the Pressure-Relief Valve on the Leak Tester may still be open and should be closed. In this case, remove and reattach the Leak Tester and repeat Steps 1-3.
4. If the pressure decreases after the connections are restored, the endoscope has a damaged seal. **Do not continue to use the endoscope or immerse it in fluids in this condition.** Contact your regional distributor or the Cogentix Medical Customer Service Center to arrange for evaluation and/or repair. When returning the endoscope, follow the instructions given in Chapter 9, **Warranty and Service**.
5. If the needle's position remains steady on the Leak Tester, immerse the entire endoscope in water, and observe it for thirty (30) seconds. Angulate the Distal Bending Section up and down while the endoscope is immersed, as holes in the soft covering of the Distal Bending Section may not be evident while it is in a relaxed position.
6. A steady stream of air bubbles at a given location indicates a small leak in the endoscope that was not detected by the pressure gauge. If a leak is detected, the air pressure in the endoscope will prevent water from entering through the leak. However, immediately remove the endoscope from the water and do not immerse it in any more fluids.

CAUTION

Do not continue to use an endoscope if leaks are detected.

Contact your local distributor or the Cogentix Medical Customer Service Center to arrange for evaluation and/or repair. When returning the endoscope, follow the instructions given in Chapter 9, **Warranty and Service**.



NOTE: Do not mistake the release of trapped air from the crevices on the endoscope's outer surface for a leak. Trapped air can be released by tapping the endoscope gently after immersing it in water.

7. The absence of air bubbles confirms that the endoscope is watertight. Remove it from the water and open the Leak Tester's Valve.
8. Make sure that the needle on the pressure gauge falls to zero (0), and **disconnect** the Leak Tester from the endoscope. The endoscope can now be safely immersed in cleaning solutions.

CAUTION

Failure to discharge/depressurize the endoscope after leak testing may place stress on the soft covering of the Insertion Tube, potentially producing a "rolling over" of the covering.

Cleaning / Disinfection / Sterilization

Use of the Vent Cap

CAUTION Failure to follow the instructions given in this section regarding the use of the Vent Cap may result in damage to the endoscope. Any such damage will void the product warranty.

The Vent Cap is to be **attached** to the endoscope prior to **all** of the following procedures in order to prevent damage to the endoscope caused by changes in pressure and temperature:

- Gas Sterilization
- Aeration
- Shipping

The Vent Cap is to be **removed** from the endoscope prior to:

- Patient Procedures
- Immersion in Fluids

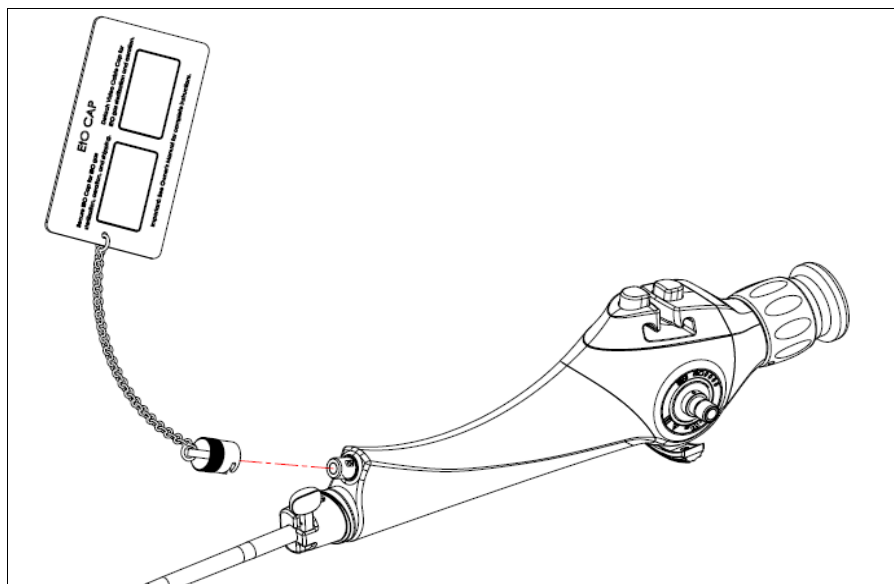

Figure 6-2: Opening the Vent Valve

Cleaning after Slide-On® EndoSheath® Technology Use

WARNING

The **Slide-On® EndoSheath® Technology** is intended for a single use only; do not reuse it. When the procedure is complete, remove the Sheath from the endoscope and dispose of it as described in Chapter 4, **Installing and Removing the Slide-On® EndoSheath® Technology**. Reusing the Sheath can present an acute infection-control risk to the user and the next patient on whom the endoscope is used.

Reprocessing

After a procedure in which the **Slide-On® EndoSheath® Technology** was attached over the endoscope's Insertion Tube, Cogentix Medical recommends performing the following prophylactic cleaning and intermediate disinfection routine between endoscopic procedures:

CAUTION Because of the possibility that a sheath could be torn, or that the endoscope or sheath could come in contact with contaminated surfaces, the user should exercise care when handling the endoscope, whether sheathed or unsheathed.

1. After removing the Sheath, inspect the Insertion Tube and Distal Bending Section, and confirm that these areas are dry. If moisture is observed, there may have been a leak into the Sheath during the procedure, providing the endoscope was dry when the sheath was attached. In this case, the endoscope must be high-level disinfected or sterilized following the instructions given in this chapter.
2. **For Cleaning** - Gently wash all external surfaces of the endoscope with an appropriate instrument-grade detergent. An ample size basin must be used for cleaning the endoscope. If the basin is too small, the endoscope may inadvertently be kinked or damaged during cleaning.
3. After washing, thoroughly rinse the outside of the endoscope with clean, lukewarm water and place it on a clean, dry surface.
4. **For Intermediate Level Disinfection** - Wipe down the entire endoscope with a soft, lint-free cloth or gauze soaked in 70% ethyl or isopropyl alcohol.
5. Ensure that all external surfaces of the endoscope are thoroughly dried prior to attaching another Sheath or storing the endoscope.

High-Level Disinfection and Sterilization

In the event that the endoscope becomes contaminated, it must be high-level disinfected and/or sterilized after cleaning. Use caution when cleaning and then high-level disinfecting or sterilizing the endoscope.

Recommended Disinfection and Sterilization Procedures

The following procedures have been determined by Cogentix Medical to be compatible with the **BRS-4000** Flexible Bronchoscope.

- **High-Level Disinfection in Glutaraldehyde:** All Cogentix Medical endoscopes are validated for high-level disinfection in 2.4% glutaraldehyde solutions. Perform the **High-Level Disinfection Protocol** described in this chapter.
- **Sterilization by Ethylene Oxide (EtO) Gas:** The endoscope may be sterilized using a validated EtO protocol. The acceptable processing parameters and procedure are given in the **EtO Gas Sterilization** section in this chapter.

- **Sterilization by STERRAD®:** The endoscope may be sterilized using a validated **STERRAD®** protocol. Refer to Table 6-1 on page 44 for the approved systems / cycles suitable for use with this endoscope.
- **Sterilization by STERIS®:** The endoscope may be sterilized using a validated **STERIS®** protocol. Refer to Table 6-1 on page 44 for the approved system suitable for use with this endoscope.

CAUTION

Disinfection and sterilization methods not listed here may be harmful to the endoscope and could cause extensive equipment damage. Please contact Cogentix Medical Customer Service to determine the compatibility of a disinfection or sterilization method not listed in this manual and/or a complete list of functionally compatible agents.

Acceptable Reprocessing Materials

Cleaning	<ul style="list-style-type: none"> • Soft Material Lint-Free Gauze (4x4) • Enzymatic Cleaner • Instrument Grade Detergent
Intermediate Level Disinfection	<ul style="list-style-type: none"> • 70% Isopropyl Alcohol or • 70% Ethyl Alcohol
High Level Disinfection	<ul style="list-style-type: none"> • 2.4% Glutaraldehyde-based solution
Sterilization	<ul style="list-style-type: none"> • EtO Gas Sterilization • STERRAD® 100S, NX, 100NX* • STERIS® System 1E*

* Endoscope **must** feature the (S) symbol for STERRAD® / STERIS® compatibility
 See STERRAD® and STERIS® Sterilization section for compatible cycles

Incompatible Methods

The high-level disinfection and sterilization chemicals and methods shown below are **not** compatible with the **BRS-4000** Flexible Bronchoscope. **DO NOT USE THEM**, as they could cause extensive damage to the endoscope. If you have any questions regarding the compatibility of a given disinfection or sterilization method, please contact your local distributor or the Cogentix Medical Customer Service Center.

Incompatible High Level Disinfection and Sterilization Methods/Chemicals		
High Level Disinfection Chemicals	DO NOT USE	<ul style="list-style-type: none"> • Chlorines • Formaldehyde • Iodophors
Sterilization Methods	DO NOT USE	<ul style="list-style-type: none"> • Autoclave • Ultrasonic

High-Level Disinfection Protocol

If the endoscope was determined to be free of leaks, it may be immersed in a glutaraldehyde solution for the amount of time recommended by the disinfectant manufacturer to achieve high-level disinfection.

CAUTION

It is imperative that the endoscope be leak tested and cleaned prior to immersion in high-level disinfectant. Failure to do so may not detect leaks that could allow fluid ingress and damage the endoscope. Failure to clean the endoscope may allow gross debris to remain on external surfaces, which could impair proper disinfection.

Cleaning

1. Gently pat down the Insertion Tube and wipe the Distal Bending Section with a soft, lint-free cloth or gauze (4x4) to remove visible debris.
2. Perform the Leak Test procedure.
3. Gently wash down all external surfaces with an enzymatic cleaning solution and soak the endoscope in the enzymatic cleaning solution for the time recommended by the enzymatic solution's manufacturer.
4. Remove the endoscope from the cleaning solution and rinse it thoroughly with clean, lukewarm water.
5. Dry all external surfaces of the endoscope.

Disinfection

1. Immerse the endoscope in the disinfectant solution at the temperature recommended by the disinfectant manufacturer.
2. Allow the endoscope to remain immersed in the disinfectant solution for the period of time recommended by the disinfectant manufacturer.
3. Following disinfection, remove the endoscope from the solution.

Rinsing

1. Immerse the endoscope in a container of clean, lukewarm water.
2. Thoroughly rinse the outside of the endoscope with clean, lukewarm water and place it on a clean, dry surface.
3. Wipe all external surfaces of the endoscope with a soft, lint-free cloth or gauze (4x4) until it is completely dry.
4. Confirm that the Objective Lens at the endoscope's Distal Tip is free of disinfectant residue.

Ethylene Oxide (EtO) Gas Sterilization

The **BRS-4000** Flexible Bronchoscope may be sterilized using a validated ethylene oxide (EtO) gas sterilization protocol, following the processing parameters given below.

CAUTION

If the Vent Valve is not open during gas sterilization, the increased heat and pressure from the sterilization process will cause pressure to build up inside the endoscope and could rupture the watertight seals and/or softer materials of the endoscope.

EtO Gas Sterilization Parameters

Temperature: $125^{\circ} \pm 5^{\circ}\text{F}$ ($52^{\circ}\text{C} \pm 3^{\circ}\text{C}$)

Relative Humidity: $50\% \pm 10\%$

EtO Concentration: 600 mg/liter

Exposure Time: 3 hours + 1/-0 hour

Post-Sterilization Aeration: 12 hours at 130°F (55°C) or 72 hours at 75°F (24°C)



NOTE: EtO Gas Sterilization at the above parameters has been validated by Cogentix Medical, and will sterilize the device to a sterility assurance level (SAL) of 10^{-6} .

Prior to EtO Gas Sterilization, the endoscope must be leak tested, pre-cleaned and dried as described for the High-Level Disinfection Protocol. Failure to properly pre-clean the endoscope may inhibit the EtO gas sterilization process.

Prior to Gas Sterilization, the Vent Valve must be opened as shown in Figure 6-2 (page 39) to accommodate the heat and pressure changes of the Gas Sterilization process. To open the Valve, press the red Vent Cap onto the Vent Valve, and rotate it clockwise until it is seated and locked.

After EtO Gas Sterilization

Effective aeration must be completed after EtO gas sterilization. Cogentix Medical recommends following the instructions-for-use supplied by the manufacturer of the gas sterilizer, and that a biological indicator is used to confirm sterilization efficacy.

STERRAD® and STERIS® Sterilization

Prior to STERRAD® and STERIS® Sterilization, the endoscope must be leak tested, cleaned and dried as described in this chapter.

The **BRS-4000** Flexible Bronchoscope has been validated for material and functional compatibility with the following sterilization systems/cycles:

STERRAD® 100S	STERRAD® NX	STERRAD® 100NX	STERIS® System 1E
✓ Short and Long Cycles	✓ Short and Long Cycles	✓ Flex Cycle Only	✓

Table 6-1: STERRAD® and STERIS® Validated Systems/Cycles

Refer to the STERRAD® or STERIS® Sterilization User's Manual for complete details on instructions for use.

CAUTION Failure to properly clean the endoscope may inhibit the STERRAD® or STERIS® sterilization process.

CAUTION The Vent Cap **must** be **attached** for the STERRAD® sterilization process. The Vent Cap must be **removed** for the STERIS® sterilization process.

CAUTION STERRAD® and STERIS® sterilization compatibility applies only to endoscopes which feature the (S) symbol on the Control Body's Identification Ring.

7 Care and Storage

Follow the instructions in this chapter if you anticipate that the endoscope will not be used for a prolonged period of time. Do not leave the endoscope exposed to the elements in these circumstances.

Storage

Follow the instructions below when storing the **BRS-4000** Flexible Bronchoscope:

- **DO NOT** store the endoscope with a **Slide-On® EndoSheath® Technology** installed on the Insertion Tube. Over time, the Sheath material may adhere to the Insertion Tube and become difficult to remove.
- When storing the endoscope, be sure to keep the Insertion Tube as straight as possible.
- The equipment should be completely clean and dry before storing.
- The endoscope should be maintained in a clean condition during storage so that it is ready for subsequent use.
- The endoscope should be stored in a dry, well ventilated environment – avoid high humidity, direct sunlight, and temperatures below -10°C or above 60°C.
- Do not store the endoscope in its carrying case. This case is only intended for endoscope transport; it is not properly ventilated for storage.
- Avoid storing the endoscope in heavily trafficked areas where there is a chance that it may sustain physical damage.

CAUTION

The endoscope should **NEVER** be stored in areas where it could be exposed to liquids or environmental conditions such as high temperature, humidity, direct sunlight, dust, salt, etc., which could adversely affect its operation.

The endoscope should **NEVER** be stored in the presence of flammable or explosive gases or chemicals.

Disposal

The equipment should be returned to Cogentix Medical for disposal. Contact your local Cogentix Medical representative or service facility for further information.

8 Troubleshooting

The information in this chapter is designed to help users diagnose problems that may occur during operation of the endoscope. The tables include some of the problems that could arise during operation, possible causes for those problems, and suggested corrective action.

CAUTION If the problem persists even after the corrective action has been taken, or a problem occurs that is not covered in the tables, do not use the endoscope. Contact Cogentix Medical for repairs using the information given in Chapter 9, **Warranty and Service**.

Troubleshooting

PROBLEM	PROBABLE CAUSE	ACTION
Angulation feels stiff	<ul style="list-style-type: none"> Damaged Distal Bending Section causing impaired angulation. 	⇒ Return the endoscope to Cogentix Medical for repair. Refer to Chapter 9, Warranty and Service.
Angulation alignment is no longer up/down	<ul style="list-style-type: none"> Insertion Tube has become twisted. 	⇒ Return the endoscope to Cogentix Medical for repair. Refer to Chapter 9, Warranty and Service.
Loss of angulation	<ul style="list-style-type: none"> Angulation wires have been stretched or broken during use. 	⇒ Return the endoscope to Cogentix Medical for repair. Refer to Chapter 9, Warranty and Service.
Cloudy or foggy images when the endoscope is unsheathed	<ul style="list-style-type: none"> Patient debris or other material on the Objective Lens. Fluid incursion into the endoscope's optical system. The lens at the Distal Tip has become damaged. 	⇒ Clean the Objective Lens with an alcohol prep pad to remove material or stain. Excess staining may not be correctable and the lens may require replacement. ⇒ Return the endoscope to Cogentix Medical for repair. Refer to Chapter 9, Warranty and Service. ⇒ Return the endoscope to Cogentix Medical for repair. Refer to Chapter 9, Warranty and Service.
Loss of illumination	<ul style="list-style-type: none"> Patient material or other substance on the Light Guides. Light Intensity is set too low. Damaged light guide fiber bundles. 	⇒ Clean the Distal Tip with an alcohol prep pad to remove material or stain. Excess staining may not be correctable and the lens may require replacement. ⇒ Adjust Light Intensity setting. ⇒ Return the endoscope to Cogentix Medical for repair. Refer to Chapter 9, Warranty and Service.

Table 8–1: Troubleshooting

PROBLEM	PROBABLE CAUSE	ACTION
Wrinkles and/or folds in the Insertion Tube	<ul style="list-style-type: none"> • These may be a result of excessive force applied to the Insertion Tube during cleaning or Sheath removal, or the long-term effects of repeated immersion in chemical disinfecting solutions, which could stretch and weaken the outer coverings. 	<ul style="list-style-type: none"> ⇒ Return the endoscope to Cogentix Medical for repair. Refer to Chapter 9, Warranty and Service.
Insertion tube is dented	<ul style="list-style-type: none"> • Dents can be caused by physical trauma to the endoscope [e.g., closing the case on the Insertion Tube]. 	<ul style="list-style-type: none"> ⇒ Return the endoscope to Cogentix Medical for repair. Refer to Chapter 9, Warranty and Service.
Loss of pressure during leak test	<ul style="list-style-type: none"> • The Leak Tester is not connected properly to the EtO Valve. • The Leak Tester's Pressure-Relief Valve is open. • A hole or crack has broken the endoscope's watertight seal. 	<ul style="list-style-type: none"> ⇒ Re-connect the Leak Tester and perform the test again. ⇒ Close the Pressure-Relief Valve. ⇒ Return the endoscope to Cogentix Medical for repair. Refer to Chapter 9, Warranty and Service.
Cannot insert endoscope into the sheath	<ul style="list-style-type: none"> • The Sheath's channel is misaligned. • The endoscope's Locking Knob is not aligned with the slot. • The endoscope's Insertion Tube has been damaged and its diameter has increased. • The Angulation Lever has been actuated. 	<ul style="list-style-type: none"> ⇒ Straighten the channel before continuing scope insertion. ⇒ Make sure the Locking Knob is positioned vertically. Align Locking Knob with slot and fully seat the endoscope in the sheath. Rotate the Locking Knob clockwise until it is horizontal. ⇒ Return the endoscope to Cogentix Medical for repair. Refer to Chapter 9, Warranty and Service. ⇒ Place the Angulation Lever in the neutral position so the Distal Bending Section of the endoscope is straight.

Troubleshooting

PROBLEM	PROBABLE CAUSE	ACTION
	<ul style="list-style-type: none"> The Sheath's Window is not aligned with the Insertion Tube. The D-shaped opening of the EndoSheath® Connector is not aligned with the Insertion Tube. The Sheath is torn or punctured. 	<ul style="list-style-type: none"> ⇒ Articulate the Insertion Tube back and forth several times to fully seat the Sheath. ⇒ Gently manipulate the edges of the Sheath's Window to fully seat it. ⇒ Align the opening of the EndoSheath® Connector with the Insertion Tube. ⇒ Replace the Sheath.
Cannot remove the endoscope from the sheath	<ul style="list-style-type: none"> Locking Knob not rotated. The Sheath is torn or punctured. The Sheath has been attached to the endoscope for an extended period of time, causing it to adhere to the Insertion Tube. The endoscope has become twisted during removal. Sheath channel is wrapped around insertion tube. The Distal Head of the Insertion Tube is lodged in the Sheath. 	<ul style="list-style-type: none"> ⇒ Rotate Locking Knob to the vertical position. ⇒ Contact your regional distributor or Cogentix Medical Customer Service for removal instructions. Disinfect/sterilize the endoscope. ⇒ Use a syringe without a needle to introduce small amounts of 70% alcohol into the opening at the proximal end of the EndoSheath® Connector. When the liquid reaches the Distal Tip of the endoscope/sheath, carefully attempt to remove the endoscope from the Sheath. If necessary, contact your Regional Distributor for removal instructions. Disinfect/sterilize the endoscope. ⇒ Align the flat side of the endoscope's Insertion Tube with the Sheath's Accessory Port and remove the endoscope from the Sheath. ⇒ Straighten channel before gently removing the Sheath. ⇒ Gently grasp the Sheath's Optical Window using the hanging drape as a barrier between your fingers and the Sheath. Then slowly and gently withdraw the endoscope from the Sheath.

PROBLEM	PROBABLE CAUSE	ACTION
<p>Glare evident when viewing through the sheath</p>	<ul style="list-style-type: none"> • The Sheath's window is not in contact with the Distal Tip of the endoscope due to: <ul style="list-style-type: none"> - Incomplete insertion into the Sheath. <p style="text-align: center;">OR</p> <ul style="list-style-type: none"> - The endoscope's tip is damaged and/or enlarged. 	<ul style="list-style-type: none"> ⇒ Move the Distal Bending Section back and forth several times to fully seat the Sheath. ⇒ Gently manipulate the edges of the Sheath's Window to properly seat the endoscope. ⇒ Remove the endoscope from the Sheath. Return the endoscope to Cogentix Medical for repair. Refer to Chapter 9, Warranty and Service.
<p>Insufficient or no suction during the procedure</p>	<ul style="list-style-type: none"> • Suction level is set too low, or the unit is malfunctioning. • Suction level may be set too high. • Suction Tubing is too tight in endoscope Pinch Valve. • Suction Tubing is kinked or crushed. • Suction Tubing is open to the atmosphere. • The wall of the Working Channel is occluded with foreign matter. 	<ul style="list-style-type: none"> ⇒ Confirm that the suction pump is set properly. Disconnect the suction line from the Sheath and test the suction level through the tubing. Reconnect the suction line. ⇒ Determine if the channel is collapsed, and reduce the setting on the external suction source. ⇒ Relieve tension on Tubing by repositioning to create more slack. ⇒ Straighten out the Suction Tubing. Make sure that the plastic clips are holding the tube to the umbilical. Take care not to apply tension to the suction tube. ⇒ The Suction Tubing may have become disconnected. Re-attach the tubing to the suction pump. ⇒ Stop applying suction. Remove the endoscope from patient and inject 10cc of saline through the channel. If after repeated attempts the channel remains blocked, remove the endoscope from the Sheath and install a new Sheath.

Troubleshooting

PROBLEM	PROBABLE CAUSE	ACTION
Cannot inject fluid through the Accessory port	<ul style="list-style-type: none"> The Suction/Working Channel is clogged The Syringe is not fully seated into or aligned with the Accessory Port. 	<ul style="list-style-type: none"> ⇒ Remove the endoscope from the patient and inject 10cc of saline through the channel. If the channel remains blocked, remove the Sheath from the endoscope and install a new Sheath. ⇒ Insert the syringe tip fully and straight into the Accessory Port.
Suction is observed without the Pinch Valve button depressed	<ul style="list-style-type: none"> The Control Body Cover is draped too tightly around the Suction Valve. Suction tubing is not properly positioned in the Pinch Valve. Sheath window is damaged. 	<ul style="list-style-type: none"> ⇒ Relieve tension on Valve by adjusting the Control Body Cover. ⇒ Properly position the Suction Tubing in the Pinch Valve following instructions in this manual. ⇒ Remove Sheath and install a new Sheath.
The Accessory will not pass through the Sheath's Working Channel	<ul style="list-style-type: none"> Accessory is too large. The Channel is occluded by patient debris. The endoscope's Distal Bending Section is angulated. 	<ul style="list-style-type: none"> ⇒ Verify that either the BF-2.8* or BF-2.1 Slide-On® EndoSheath® Technology is being used. Check the diameter of the accessory. Make sure that the Accessory is compatible with a 2.8 mm or 2.1 mm Working Channel. (*available in select markets only) ⇒ Remove the endoscope from the patient and inject 10cc of saline through the Channel. If, after repeated attempts, the channel remains blocked, remove the Sheath from the endoscope and install a new one. Do not force the Accessory through the working Channel as this may damage the Channel and compromise the integrity of the barrier. ⇒ Maneuver the endoscope's Distal Tip to an area of the anatomy in which it can safely be straightened. Insert accessory until its tip can be seen when looking through eyepiece. Now angulate the endoscope's Distal Bending Section and proceed to desired area.

9 Warranty and Service

Warranty Information



NOTE: Alterations or repairs done by persons not authorized by Cogentix Medical will void this warranty.

Cogentix Medical is not liable for any damages to the **BRS-4000** Flexible Bronchoscope resulting from misuse, negligence, or improper cleaning or storage. The warranty defined herein shall apply only to the original buyer. In no event shall Cogentix Medical be liable for anticipated profits, consequential damages or loss of time incurred by the buyer with the purchase or use of this equipment.

NOTE: Cogentix Medical sells many of its products through regional distributors. Before sending equipment to Cogentix Medical, contact your regional distributor for repair/return procedures.

Cogentix Medical warrants that the **BRS-4000** Flexible Bronchoscope and its accessories will be free from defects in materials and workmanship **for a period of one year from the date of the invoice**. Replacement parts are warranted **for a period of ninety (90) days from the date of the invoice**.

All non-warranty repairs will be warranted to be free from defects in materials and workmanship **for a period of ninety (90) days from the date of the invoice**.

Upon receipt of a **BRS-4000** Flexible Bronchoscope for repair, Cogentix Medical will evaluate the instrument and make the final decision as to the warranty status.

The above warranties are in lieu of all other warranties, either expressed or implied, including warranties of fitness or merchantability.

Cogentix Medical Service Information

BRS-4000 Flexible Bronchoscopes are serviced at authorized Cogentix Medical repair facilities only. Use the following procedure to expedite returned goods for repair or replacement:

1. Telephone your Regional Distributor, Territory Manager, or Cogentix Medical Customer Service, (Monday through Friday from 8:00 AM to 7:00 PM EST).

USA customers call 866-258-2182 (toll free in U.S.)

International customers call (+1) 952-426-6189 for Cogentix Medical Customer Service or call your regional distributor

Warranty and Service

Fax 866 255-4522 (toll free in U.S.)

Fax 952 426-6199 (international)

Email: customer care@cogentixmedical.com

2. Provide a detailed description of the problem.
3. If troubleshooting cannot solve the problem, a Returned Goods Authorization (RGA) number will be issued.
4. Complete an Incident Report Form and send it to Cogentix Medical along with the returned goods. Returned merchandise will only be accepted with an RGA number.

Shipping to Cogentix Medical or Distributor

WARNING

If the **BRS-4000** Flexible Bronchoscope has been used in a clinical procedure, disinfect all system components before shipping as described in Chapter 6, **Reprocessing**. Shipping contaminated equipment could present an acute infection-control risk for those handling the endoscope, both during shipping and at Cogentix Medical or authorized repair facility.

If the **BRS-4000** Flexible Bronchoscope has been used in a clinical procedure **but cannot be disinfected before shipping, place a red biohazard label** on the shipping container to indicate that the contents are contaminated, in accordance with OSHA standards 29 CFR 1910.1030.

Observe the following precautions before shipping the endoscope:

1. Attach the Vent Cap to the endoscope's Vent Valve in preparation for shipping.
2. If the endoscope has a leak or tear or fails the leak test, or for some other reason cannot be disinfected properly as described in Chapter 6, **Reprocessing**, wipe the endoscope down with 70% ethyl or isopropyl alcohol to remove debris. Indicate on the outer package that the contents are contaminated.
3. Ship the endoscope in its carrying case. Place the carrying case inside a corrugated box containing protective shipping material to prevent damage during shipment.

Regardless of warranty status, all shipping charges to and from an authorized Cogentix Medical facility are the responsibility of the customer.



NOTE: The customer will be contacted and advised of the estimated repair costs. Repairs will not begin on any equipment until authorization or a purchase order has been issued indicating approval of the charges.

Appendix

Specifications

BRS-4000		
Insertion Tube Diameter (Nominal)	BF-2.8* Sheath	5.9 mm (with sheath)
	BF-2.1 Sheath	5.6 mm (with sheath)
	BF-1.5 Sheath	5.2 mm (with sheath)
	BF-0 Sheath	4.1 mm (with sheath)
Insertion Tube Working Length		570mm (w/ sheath)
Field of View		90°
Direction of View		Forward
Depth of Field		3 - 50 mm
Environmental Effects on Optical Performance		None
Angulation - with Sheath and without accessory tool		215° Up /140° Down
Working Channel Diameter	BF-2.8* Sheath	2.8 mm (8.4Fr)
	BF-2.1 Sheath	2.1 mm (6.3Fr)
	BF-1.5 Sheath	1.5 mm (4.5Fr)
	BF-0 Sheath	No Channel
Operating Environment		
Temperature		50° to 104° F (10° to 40° C)
Relative Humidity		30 to 85%
Air Pressure		700 to 1060 hPa
Storage Environment		
Temperature		14° to 140° F (-10° to +60° C)
Relative Humidity		0 to 95%
Air Pressure		700 to 1060 hPa
Mode of Operation		Continuous
Electrical Safety		IEC 60601-1 & IEC 60601-2-18
Thermal Safety		IEC 60601-1 & IEC 60601-2-18
Degree of Protection Against Electrical Shock		Type BF
Degree of Protection Against Invasion of Liquids		IPX7: Fully Immersible (as per Reprocessing Instructions)

Table A-1: Specifications

*Available in select markets only

Infection Control Information

The **Slide-On[®] EndoSheath[®] Technology** for the **BRS-4000** Bronchoscope is designed to offer practitioners the ability to perform safe, efficient endoscopy. The **EndoSheath[®] Technology** is a proven effective barrier to microorganisms as small as 27 nanometers.¹ Efficacy testing for barrier qualities has been performed by an independent laboratory per FDA required guidelines². All **EndoSheath[®] Technology** units undergo a rigorous quality assurance process to ensure the utmost in product quality and efficacy.

Please contact Cogentix Medical Customer Service for a detailed information packet regarding infection-control issues related to the **EndoSheath[®] Technology**.

¹ Viral challenge testing performed with bacteriophage 27 nanometers in size, per FDA guidance.

² As required by FDA clearance requirements, barriers must be tested by the guidelines set within the "FDA Guidance for Manufacturers Seeking Marketing Clearance of ... Endoscope Sheaths Used as Protective Barriers"

Cogentix

Medical



Cogentix Medical, Inc.
40 Ramland Road South
Orangeburg, NY 10962 USA
Tel.: 866 258-2182 (toll free in U.S.)
Tel.: (+1) 952 426-6189 (international)
Fax: 866 255-4522 (toll free in U.S.)
Fax: (+1) 952 426-6199 (international)
email: customercare@kogentixmedical.com

www.kogentixmedical.com

For additional product information or questions pertaining to sales and service, please contact the local distributor or the manufacturer.



MedPass International Ltd.
Windsor House, Bretforton
Evesham, Worcestershire
WR11 7JJ, United Kingdom



0843

© 2009, 2010, 2012, 2013, 2014, 2015 Cogentix Medical • Slide-On and EndoSheath are registered trademarks of Cogentix Medical

Covered by one or more of the following U.S. Patents: 6,350,231; 6,530,881; 6,733,440. Other U.S. and international patents pending.

12/15 11760-EN Rev. F (19415)