

SERVICE INSTRUCTION M20-80
DATE 8-15-87

SUBJECT: TS10-360-GB, -LB & -MB ENGINES - TURBO-CHARGER CHECK VALVE CLAMPS INSPECTION.

MODELS/S/N AFFECTED: MOONEY M20K, S/N 25-0001 THRU 25-1120, 25-1122, 25-1123, 25-1124, 25-1125, 25-1128, 25-1132, & 25-1133

TIME OF COMPLIANCE: WITHIN NEXT 25 HOURS

INTRODUCTION: The clamps retaining the check valves and hoses on some of the above S/N aircraft have shown deterioration of the rubber which allows the metal band of clamp to chafe on the check valves or hoses. If not corrected, this chafing could wear through the check valve or hose and cause oil exhaustion and subsequent engine failure. New clamps, with oil and fuel resistant rubber cushioning, are provided for replacements.

INSTRUCTIONS: REFER TO TELEDYNE CONTINENTAL MOTORS (TCM) SERVICE BULLETIN NO. M87-14, DATED JULY 8, 1987 FOR RETROFIT INSTRUCTIONS AND WARRANTY COVERAGE.

REFERENCE DATA: TCM SERVICE BULLETIN M87-14, DATED JULY 8, 1987

PARTS LIST: SEE TCM SERVICE BULLETIN M87-14

**FIGURES/
TABLES:** SEE TCM SERVICE BULLETIN M87-14

service bulletin

M87-14

Technical Portions Are
FAA Approved

8 July 1987

SUBJECT: TURBOCHARGER CHECK VALVE CLAMPS

MODELS TSIO360GB - All
AFFECTED: TSIO360LB (New) - All through S/N 316128
TSIO360LB (Rebuilt) - All through S/N 247112
TSIO360MB - All through S/N 317141

COMPLIANCE: Within the next 25 hours

The clamp retaining the check valves and hoses on the above mentioned engines have, in some cases, exhibited premature deterioration of the rubber which then allows the metal band of the clamp to chafe directly on the hose or check valve as the case may be. If not corrected this chafing could wear through the check valve or hose and cause oil exhaustion and subsequent engine failure.

It is, therefore, required that these clamps be replaced with the current part number clamp. Inspect the check valves and hose for evidence of chafing. If present, the valve(s) or hose must also be replaced.

The new clamp part numbers are shown in Figure 1. (A total of three clamps.) These new clamps incorporate a cushion that is yellow in color; the clamps being replaced have a cushion that is black in color.

Installation of these clamps and routing of the hoses must be done in such a manner as to avoid placing the check valves in a bind in the clamp as this could cause a similar wear pattern.

WARRANTY: Parts and labor (up to 1 hour) required to comply with this service bulletin is covered by the TCM Gold Medallion Warranty subject to its terms and conditions. Warranty claims may be filed through any TCM distributor.

NOTE: This clamp does not require change.

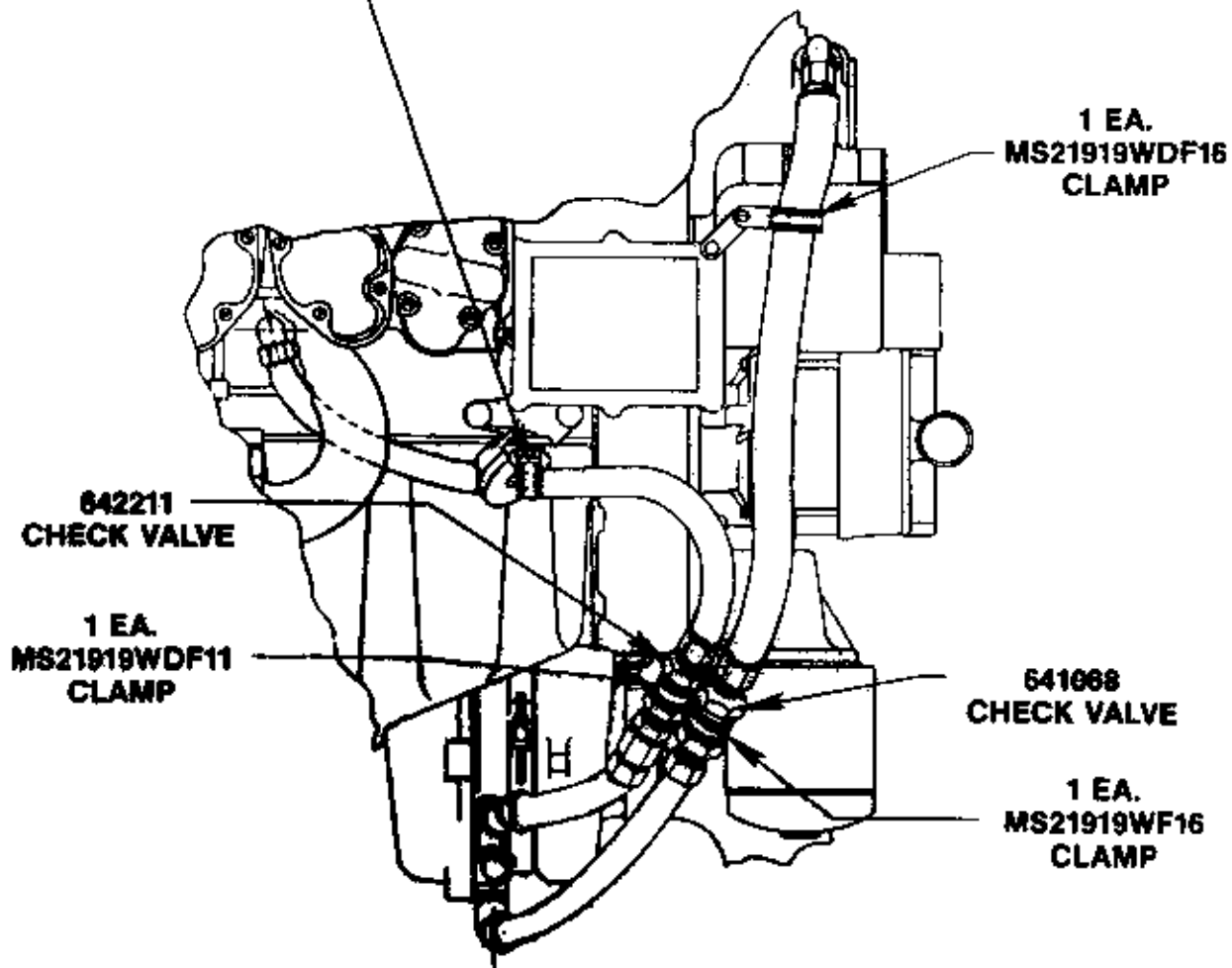

FIGURE 1