

1. Manifolds 4" ANSI Class 150 AISI 316SS
Schedule 10s ASTMA212 or $\text{Ø}114.3\text{mm} \times 2\text{mm}$.
2. Base/Frame AISI304SS.
3. 2" NPT Ball Valve for pump isolation.
4. UL Type I2 rated electrical panel. Panel size may vary.

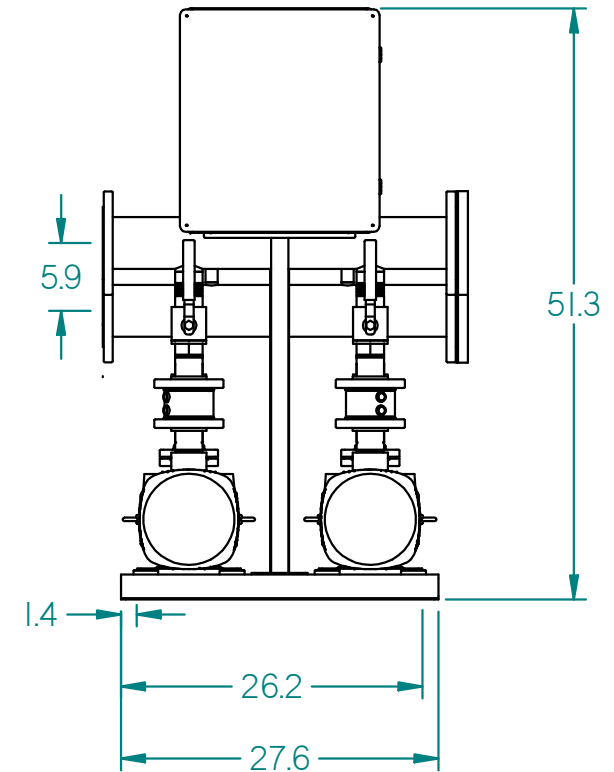

HURLEY ENGINEERING
MANUFACTURERS REPRESENTATIVES

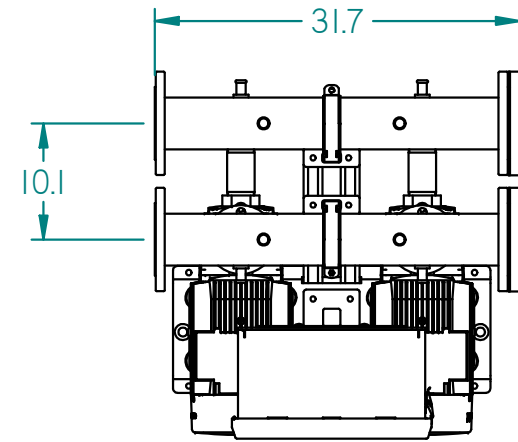
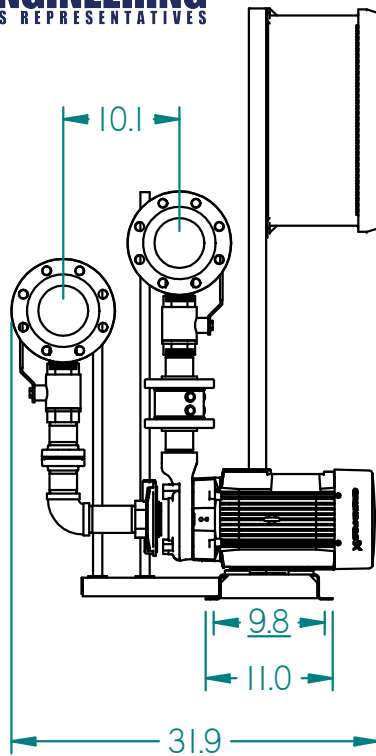

GRUNDFOS 
FRESNO, CALIFORNIA 93727 USA

Note:
All dimensions are $\pm 0.5"$
Not for construction use.
All dimensions subject to change
without notice.

BoosterpaQ Model:		Hydro Multi-B/E 2CME25-2		
Power:		7.5 HP 3x230V 60HZ		
Job:				
Dwg No:	Rev: 0	Date: 01/31/2017	Drawer: 58847	Page: 1 of 1