

PROJECT:	TPE3 READY TO SHIP	UNIT TAG:	_____	QUANTITY:	1
REPRESENTATIVE:	Hurley Engineering	TYPE OF SERVICE:	_____	DATE:	2/10/2020
ENGINEER:	_____	SUBMITTED BY:	Devin Carle	DATE:	_____
CONTRACTOR:	To Be Determined	APPROVED BY:	_____	DATE:	_____
		ORDER NO.:	_____	DATE:	_____



Product photo could vary from the actual product

TPE2 80-150 N-A-G-A-BQQE-HCB

Single-stage in-line pumps with frequency converters

Conditions of Service	Pump Data	Motor Data
Flow: 200 US gpm	Liquid temperature range: -13 .. 248 °F	Rated power - P2: 2 HP
Head: 31.83 ft	Maximum ambient temperature: 122 °F	Rated voltage: 440-480 V
Efficiency: 71.5 %	Shaft seal: BQQE	Main frequency: 60 Hz
Liquid: Water	Pipe connection: DN 80	Number of poles: 0
Temperature: 68 °F	Product number: 98817787	Enclosure class: IP55
NPSH required: 15.07 ft		Insulation class: F
Viscosity: _____		Motor protection: YES
Specific Gravity: 1.000		Motor type: 90C
		Motor_efficiency: 89.4 %

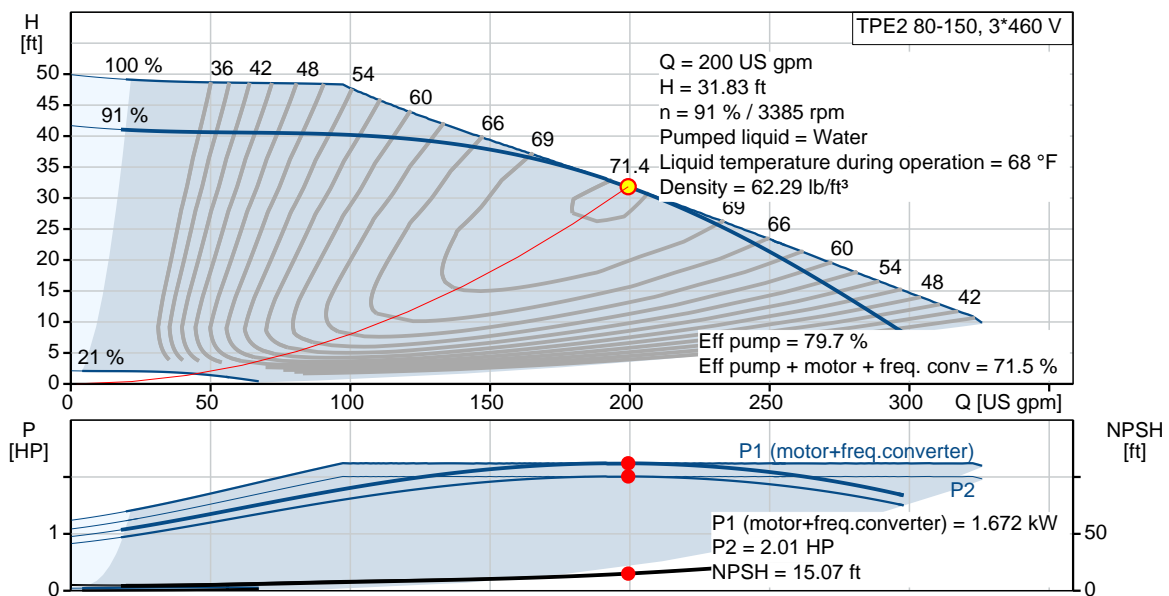

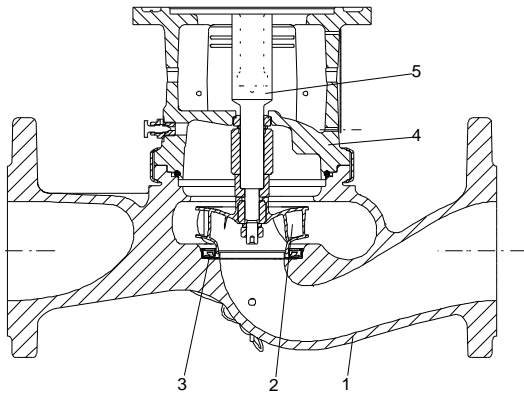
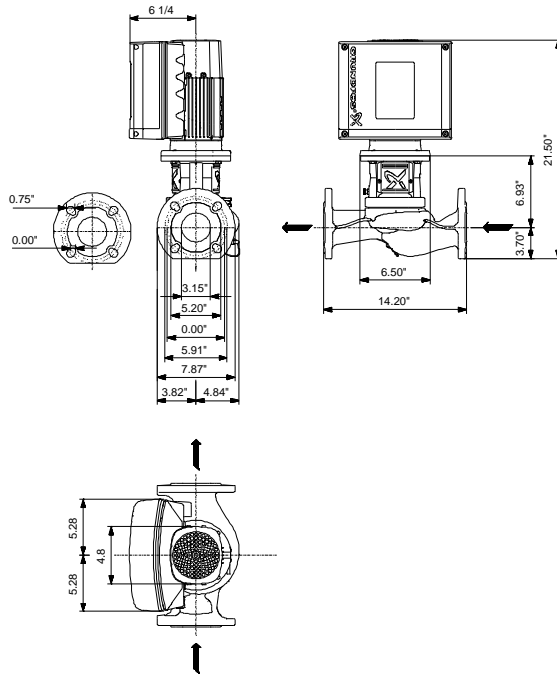

Materials:

- Pump housing: Cast iron
ASTM A48-40 B
- Impeller: Composite PES/PP 30%
GF
- Material code: A

Count	Description
-------	-------------

1	TPE2 80-150 N-A-G-A-BQQE-HCB
---	------------------------------



Product photo could vary from the actual product

Product No.: [98817787](#)

The pump is of the top-pull-out design, i.e. the power head (motor, pump head and impeller) can be removed for maintenance or service while the pump housing remains in the pipework.

The shaft seal is according to EN 12756. Pipework connection is via PN 16 ANSI flanges.

Pipework connection is via PN 16 ANSI flanges.

The pump is fitted with a fan-cooled, permanent-magnet synchronous motor. The motor efficiency is classified as IE5 in accordance with IEC 60034-30-2.

The motor includes a frequency converter and PI controller in the motor terminal box. This enables continuously variable control of the motor speed, which again enables adaptation of the performance to a given requirement.

Further product details

The operating panel on the motor terminal box features a four-inch TFT display, push-buttons and the Grundfos Eye indicator.

The display gives an intuitive and user-friendly interface to all functions. The push-buttons are used to navigate through the menu structure to access pump and performance data on site and enable setting of required setpoint as well as setting of pump to "Min." or "Max." operation or to "Stop".

Communication with the pump is also possible by means of Grundfos GO Remote (accessory). The remote control enables further settings as well as reading out of a number of parameters such as "Actual value", "Speed", "Power input" and total "Power consumption".

The Grundfos Eye indicator on the operating panel provides visual indication of pump status:

- "Power on": Motor is running (rotating green indicator lights) or not running (permanently green indicator lights)
- "Warning": Motor is still running (rotating yellow indicator lights) or has stopped (permanently yellow indicator lights)
- "Alarm": Motor has stopped (flashing red indicator lights).

Pump

Pump housing and pump head are electrocoated to improve the corrosion resistance.

Electrocoating includes:

- 1) Alkaline-based cleaning.



Company name: Hurley Engineering
Created by:
Phone:

Date: 2/28/2020

Count	Description
	<p>2) Pretreatment with zinc phosphate coating. 3) Cathodic electrocoating (epoxy). 4) Curing of paint film at 200-250 °C.</p> <p>The pump is fitted with an unbalanced rubber bellows seal with torque transmission across the spring and around the bellows. Due to the bellows, the seal does not wear the shaft, and the axial movement is not prevented by deposits on the shaft.</p> <p>Primary seal:</p> <ul style="list-style-type: none">• Rotating seal ring material: silicon carbide (SiC)• Stationary seat material: silicon carbide (SiC) <p>This material pairing is used where higher corrosion resistance is required. The high hardness of this material pairing offers good resistance against abrasive particles.</p> <p>Secondary seal material: EPDM (ethylene-propylene rubber) EPDM has excellent resistance to hot water. EPDM is not suitable for mineral oils.</p> <p>A circulation of liquid through the duct of the air vent screw ensures lubrication and cooling of the shaft seal.</p> <p>Motor</p> <p>The motor is a totally enclosed, fan-cooled motor with principal dimensions to IEC and DIN standards. Electrical tolerances comply with IEC 60034.</p> <p>The motor efficiency is classified as IE5 in accordance with IEC 60034-30-2.</p> <p>Technical data</p> <p>Controls:</p> <p>Frequency converter: Built-in</p> <p>Liquid:</p> <p>Pumped liquid: Water Liquid temperature range: -13 .. 248 °F Selected liquid temperature: 68 °F Density: 62.29 lb/ft³</p> <p>Technical:</p> <p>Pump speed on which pump data is based: 3400 rpm Actual calculated flow: 200 US gpm Resulting head of the pump: 31.83 ft Actual impeller diameter: 3.54 in Code for shaft seal: BQQE Curve tolerance: ISO9906:2012 3B2</p> <p>Materials:</p> <p>Pump housing: Cast iron ASTM A48-40 B EN 1561 EN-GJL-250</p> <p>Impeller: Composite PES/PP 30% GF</p> <p>Installation:</p> <p>Range of ambient temperature: -4 .. 122 °F Maximum operating pressure: PN 16 bar</p>



Company name: Hurley Engineering
Created by:
Phone:

Date: 2/28/2020

Count	Description
	Type of connection: ANSI Pipe connection: DN 80 Pressure rating for pipe connection: PN 16 Flange size for motor: 56C
	Electrical data:
	Motor type: 90C IE Efficiency class: IE5 Rated power - P2: 2 HP Main frequency: 60 Hz Rated voltage: 3 x 440-480 V Rated current: 2.65 A Cos phi - power factor: 0.87 Rated speed: 360-4000 rpm IE efficiency: 89.4% Motor efficiency at full load: 89.4 % Number of poles: 0 Enclosure class (IEC 34-5): IP55 Insulation class (IEC 85): F Motor Number: 99630348
	Others:
	DOE Pump Energy Index VL: 0.42 Net weight: 83.1 lb Gross weight: 102 lb



Company name: Hurley Engineering
Created by:
Phone:

Date: 2/28/2020

98817787 TPE2 80-150 N-A-G-A-BQQE-HCB 60 Hz

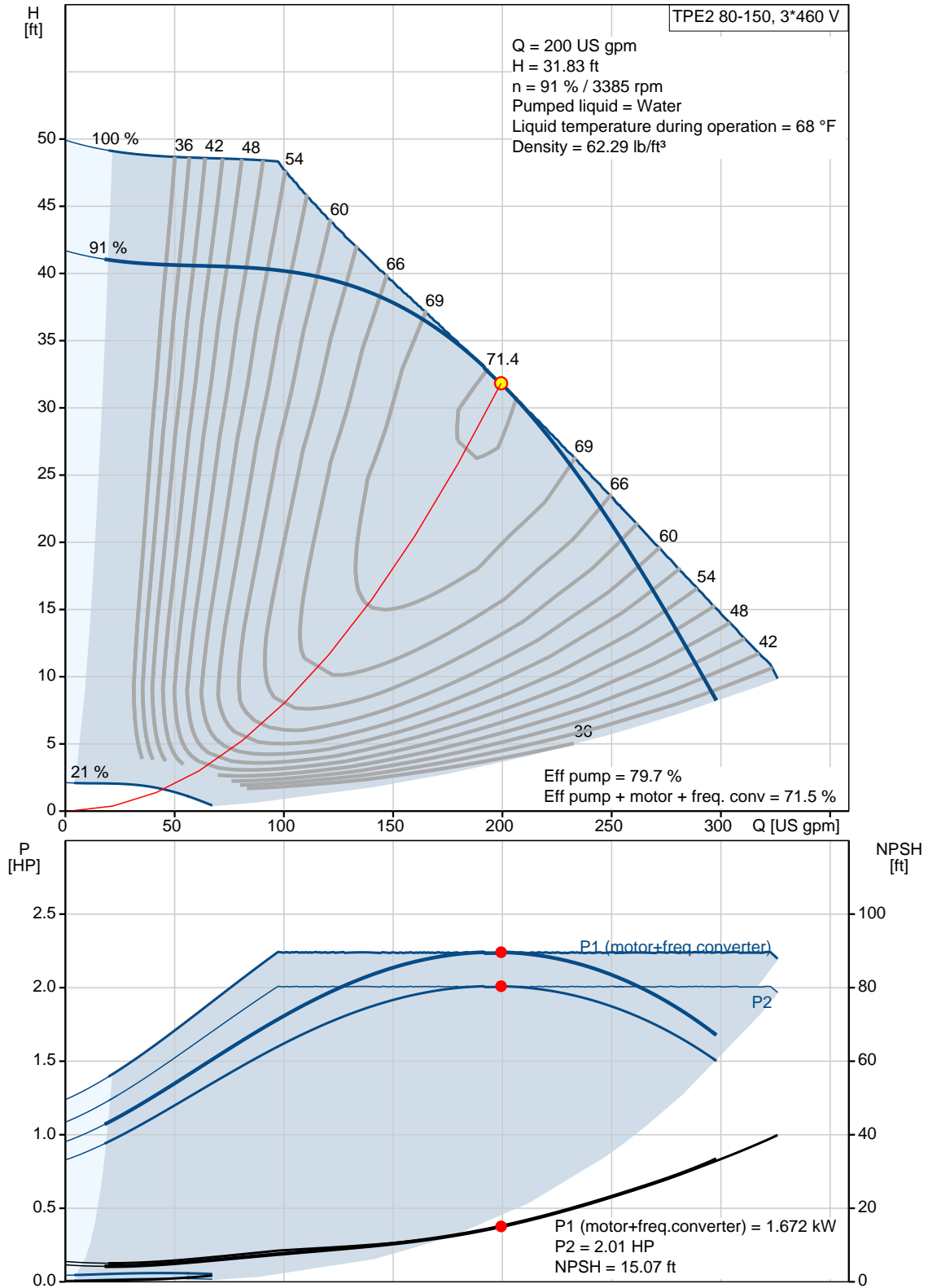

Description	Value
General information:	
Product name:	TPE2 80-150 N-A-G-A-BQQE-HCB
Product No.:	98817787
EAN:	5712601811262 5712601811262
Technical:	
Pump speed on which pump data is based:	3400 rpm
Actual calculated flow:	200 US gpm
Resulting head of the pump:	31.83 ft
Head max:	49.22 ft
Actual impeller diameter:	3.54 in
Code for shaft seal:	BQQE
Curve tolerance:	ISO9906:2012 3B2
Pump version:	A
Materials:	
Pump housing:	Cast iron ASTM A48-40 B EN 1561 EN-GJL-250
Impeller:	Composite PES/PP 30% GF
Material code:	A
Installation:	
Range of ambient temperature:	-4 .. 122 °F
Maximum operating pressure:	PN 16 bar
Type of connection:	ANSI
Pipe connection:	DN 80
Pressure rating for pipe connection:	PN 16
Flange size for motor:	56C
Connect code:	G
Liquid:	
Pumped liquid:	Water
Liquid temperature range:	-13 .. 248 °F
Selected liquid temperature:	68 °F
Density:	62.29 lb/ft³
Electrical data:	
Motor type:	90C
IE Efficiency class:	IE5
Rated power - P2:	2 HP
Main frequency:	60 Hz
Rated voltage:	3 x 440-480 V
Rated current:	2.65 A
Cos phi - power factor:	0.87
Rated speed:	360-4000 rpm
IE efficiency:	89.4%
Motor efficiency at full load:	89.4 %
Number of poles:	0
Enclosure class (IEC 34-5):	IP55
Insulation class (IEC 85):	F
Motor protection:	YES
Motor Number:	99630348

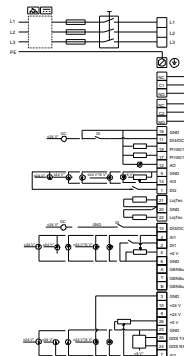
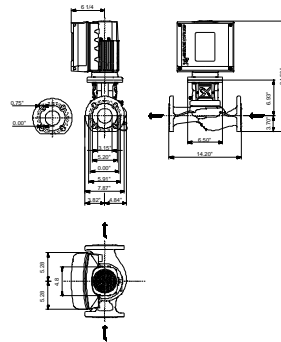
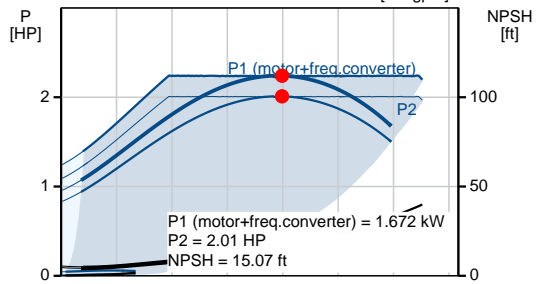
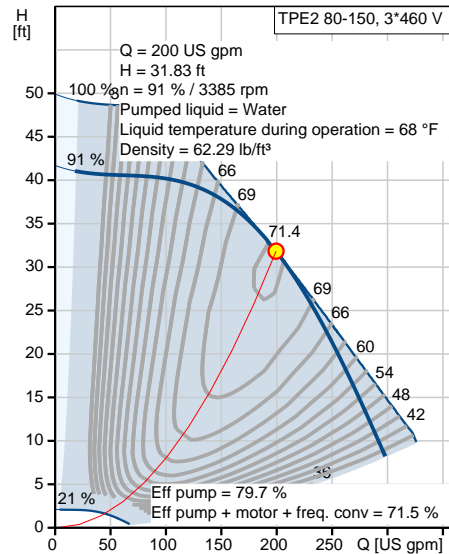



Company name: Hurley Engineering
Created by:
Phone:

Date: 2/28/2020

Description	Value
Controls:	
Control panel:	HMI300 - Graphical
Function Module:	FM300 - Advanced
Frequency converter:	Built-in
Others:	
DOE Pump Energy Index VL:	0.42
Net weight:	83.1 lb
Gross weight:	102 lb
Config. file no:	98819269

98817787 TPE2 80-150 N-A-G-A-BQQE-HCB 60 Hz

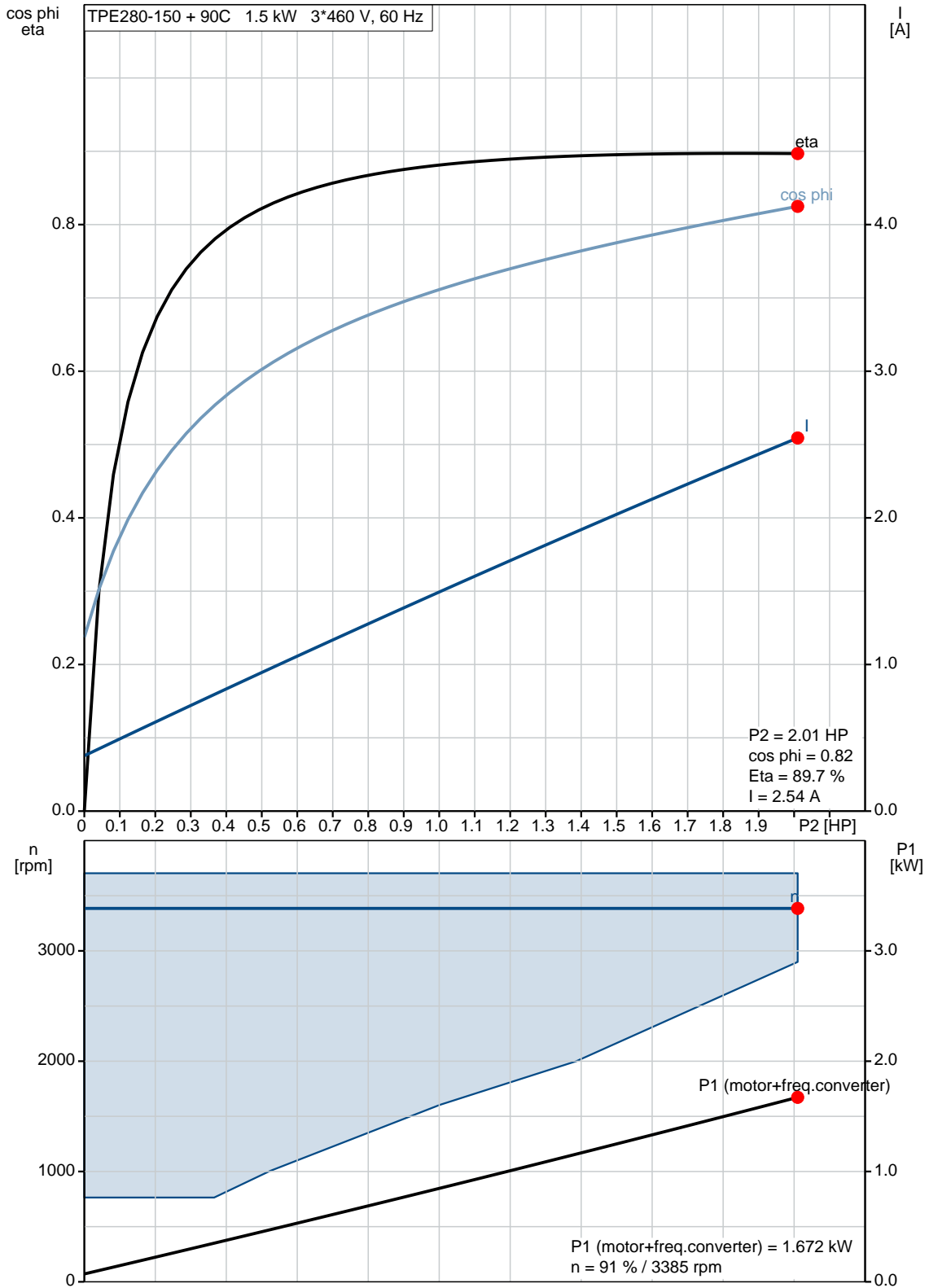

98817787 TPE2 80-150 N-A-G-A-BQQE-HCB 60 Hz

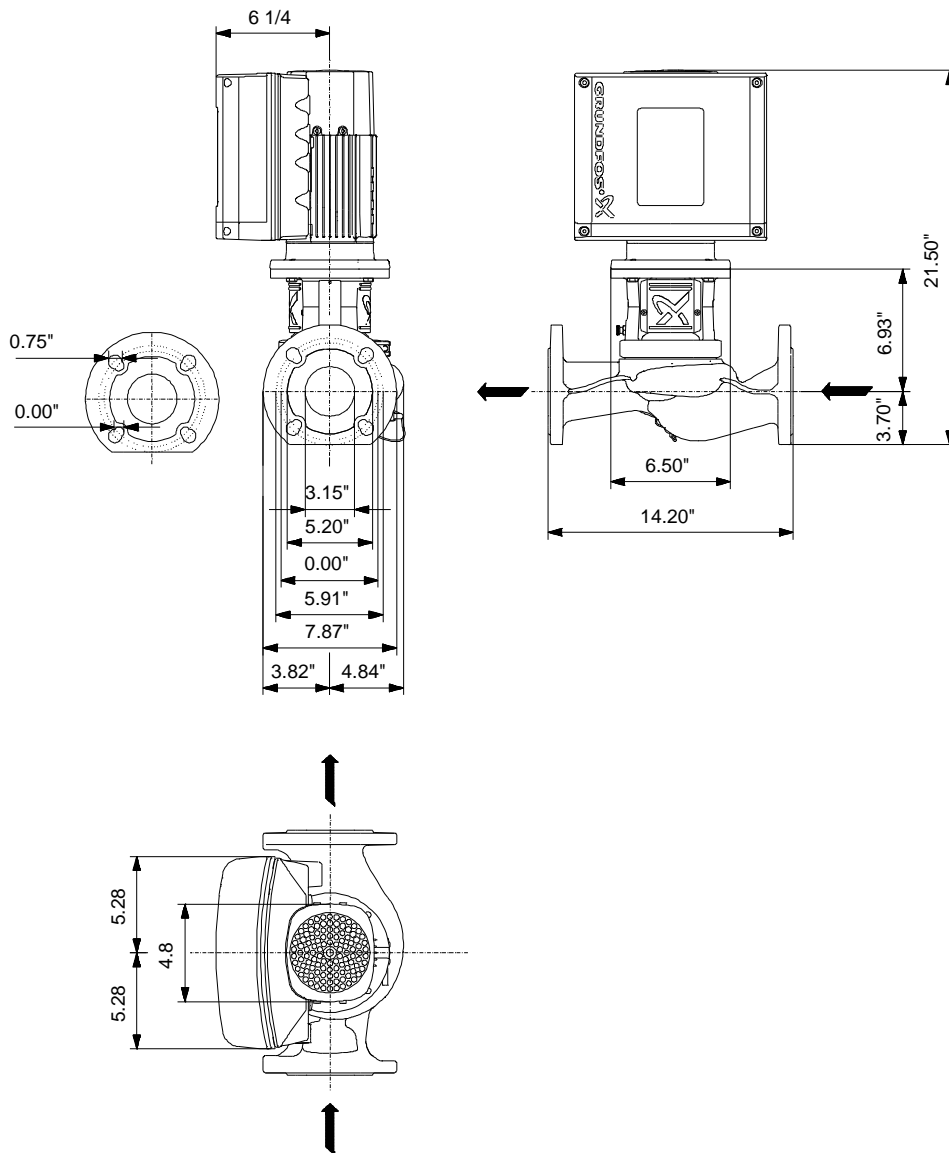

Note! All units are in [in] unless otherwise stated.
 Disclaimer: This simplified dimensional drawing does not show all details.

98817787 TPE2 80-150 N-A-G-A-BQQE-HCB 60 Hz

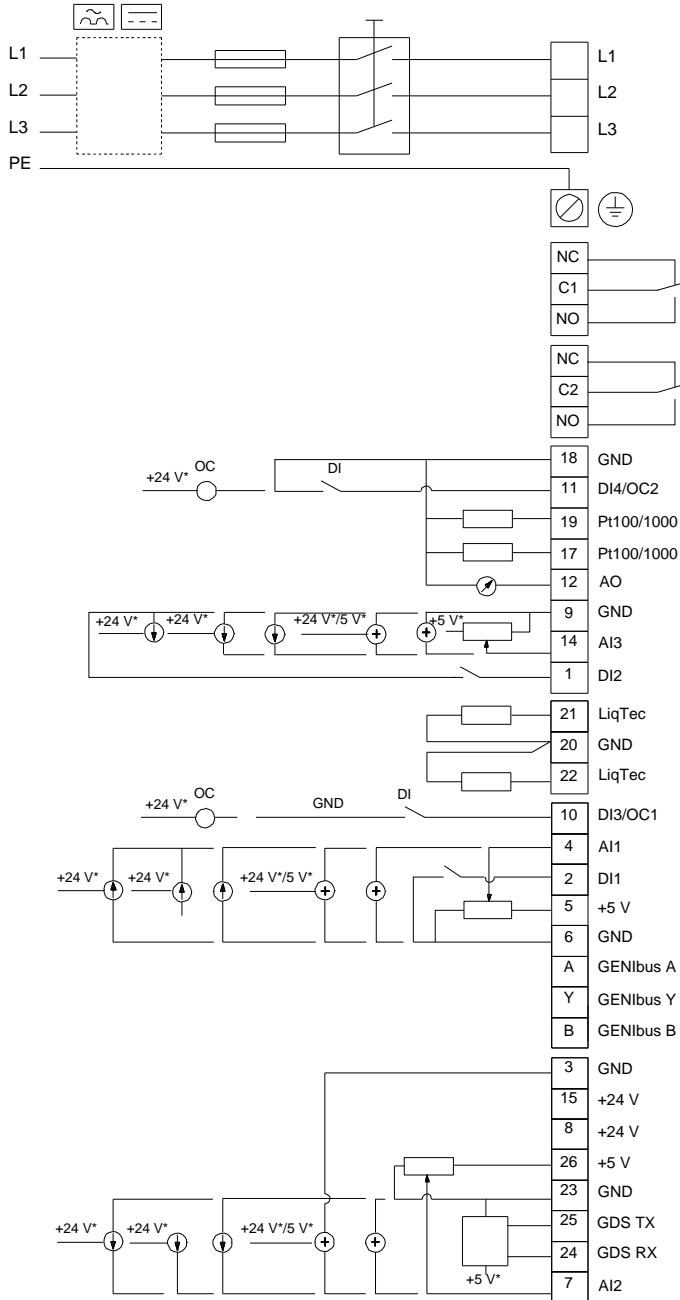

All units are [in] unless otherwise presented.



Company name: Hurley Engineering
Created by:
Phone:

Date: 2/28/2020

Order Data:

Product name: TPE2 80-150 N-A-G-A-BQQE-HCB
Amount: 1
Product No.: 98817787

Total: Price on request
