

PROJECT:	TPE3 READY TO SHIP	UNIT TAG:	_____	QUANTITY:	1
REPRESENTATIVE:	Hurley Engineering	TYPE OF SERVICE:	_____	DATE:	2/10/2020
ENGINEER:	_____	SUBMITTED BY:	Devin Carle	DATE:	_____
CONTRACTOR:	To Be Determined	APPROVED BY:	_____	DATE:	_____
		ORDER NO.:	_____	DATE:	_____



Product photo could vary from the actual product

TPE2 D 80-150 N-A-G-A-BQQE-HCB

Twin-head single-stage in-line pumps with frequency converters

Conditions of Service		Pump Data		Motor Data	
Flow:	188 US gpm	Liquid temperature range:	-13 .. 248 °F	Rated power - P2:	2 HP
Head:	31.96 ft	Maximum ambient temperature:	122 °F	Rated voltage:	440-480 V
Efficiency:	67.5 %	Shaft seal:	BQQE	Main frequency:	60 Hz
Liquid:	Water	Pipe connection:	DN 80	Enclosure class:	IP55
Temperature:	68 °F	Product number:	98817820	Insulation class:	F
NPSH required:	13.48 ft			Motor protection:	YES
Viscosity:	_____			Motor type:	90C
Specific Gravity:	1.000			Motor_efficiency:	89.4 %

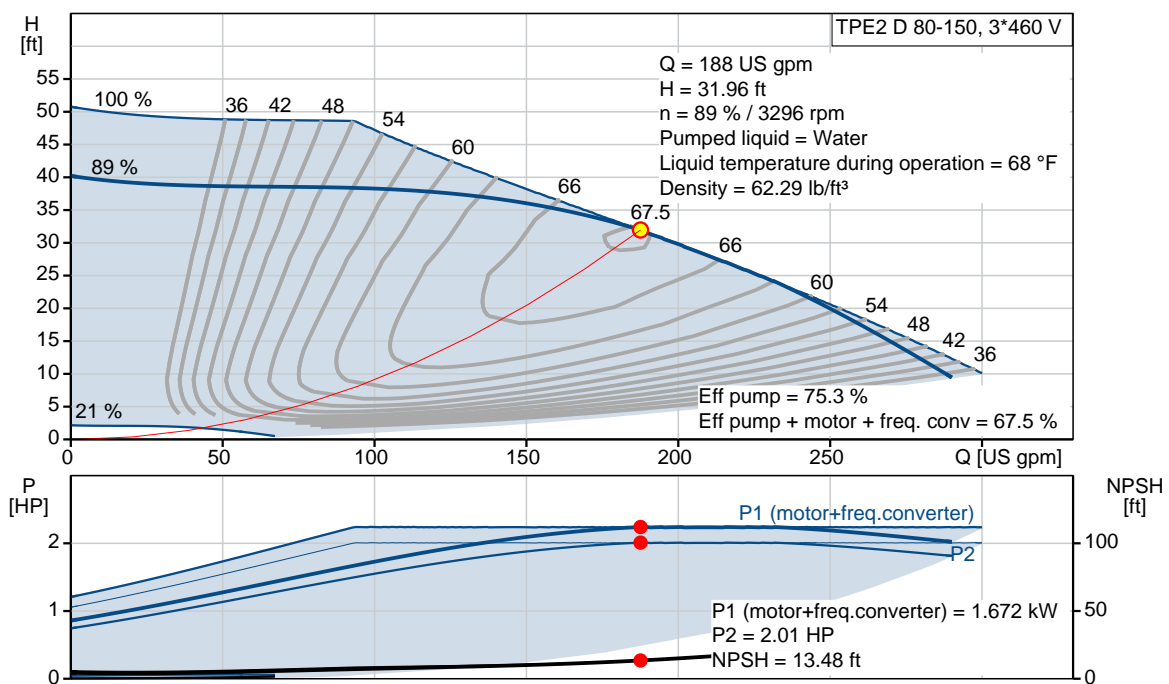

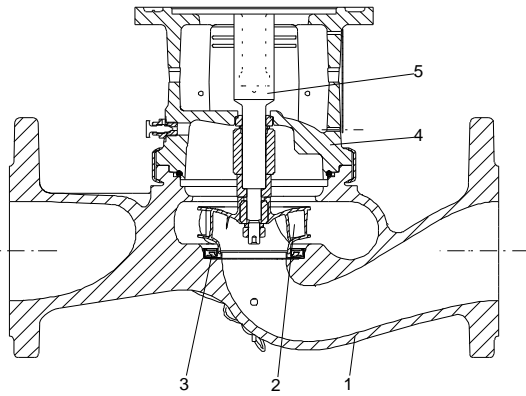
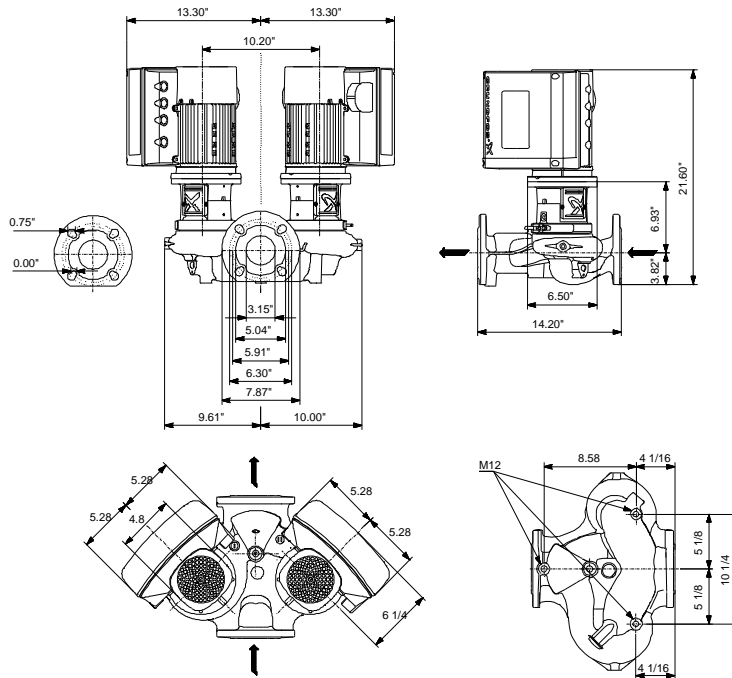

Materials:

- Pump housing: Cast iron
ASTM A48-40 B
- Impeller: Composite PES/PP 30%
GF
- Material code: A

Count	Description
1	<p>TPE2 D 80-150 N-A-G-A-BQQE-HCB</p>  <p>Product No.: 98817820</p> <p>Single-stage, close-coupled, volute twin-head pump with in-line suction and discharge ports of identical diameter. The twin-head pump is designed with two parallel power-heads. The pump is of the top-pull-out design, i.e. the power head (motor, pump head and impeller) can be removed for maintenance or service while the pump housing remains in the pipework.</p> <p>Each power head is fitted with an unbalanced rubber bellows seal. The shaft seal is according to EN 12756. Pipework connection is via PN 16 ANSI flanges.</p> <p>Pipework connection is via PN 16 ANSI flanges.</p> <p>Each power head is fitted with a fan-cooled, permanent-magnet synchronous motor of identical size. The motor efficiency is classified as IE5 in accordance with IEC 60034-30-2.</p> <p>The motor includes a frequency converter and PI controller in the motor terminal box. This enables continuously variable control of the motor speed, which again enables adaptation of the performance to a given requirement.</p> <p>Further product details</p> <p>Wireless communication between the two power heads is quickly and easily obtained. The pump heads can be set to cascade mode, alternating mode or duty/standby.</p> <p>The operating panel on the motor terminal box features a four-inch TFT display, push-buttons and the Grundfos Eye indicator.</p> <p>The display gives an intuitive and user-friendly interface to all functions. The push-buttons are used to navigate through the menu structure to access pump and performance data on site and enable setting of required setpoint as well as setting of pump to "Min." or "Max." operation or to "Stop".</p> <p>Communication with the pump is also possible by means of Grundfos GO Remote (accessory). The remote control enables further settings as well as reading out of a number of parameters such as "Actual value", "Speed", "Power input" and total "Power consumption".</p> <p>The Grundfos Eye indicator on the operating panel provides visual indication of pump status:</p> <ul style="list-style-type: none">• "Power on": Motor is running (rotating green indicator lights) or not running (permanently green indicator lights)• "Warning": Motor is still running (rotating yellow indicator lights) or has stopped (permanently yellow indicator lights)• "Alarm": Motor has stopped (flashing red indicator lights). <p>Pump</p> <p>Pump housing and pump head are electrocoated to improve the corrosion resistance. Electrocoating includes:</p> <ol style="list-style-type: none">1) Alkaline-based cleaning.2) Pretreatment with zinc phosphate coating.

Count	Description
-------	-------------

- 3) Cathodic electrocoating (epoxy).
- 4) Curing of paint film at 200-250 °C.

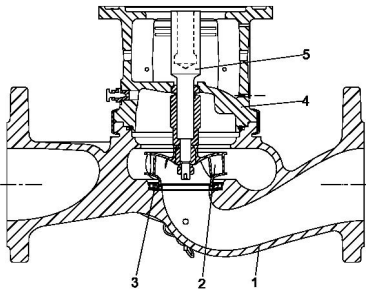

- 1: Pump housing
- 2: Impeller
- 3: Neck ring
- 4: Pump head/motor stool
- 5: Stub shaft

The twin-head pump is designed with two parallel power-heads. A flap valve in the common discharge port is opened by the flow of the pumped liquid and prevents backflow of liquid into the idle pump head.

The pump housing is provided with a replaceable stainless steel/PTFE neck ring to reduce the amount of liquid running from the discharge side of the impeller to the suction side. The impeller is secured to the shaft with a nut.

The pump is fitted with an unbalanced rubber bellows seal with torque transmission across the spring and around the bellows. Due to the bellows, the seal does not wear the shaft, and the axial movement is not prevented by deposits on the shaft.

Primary seal:

- Rotating seal ring material: silicon carbide (SiC)
- Stationary seat material: silicon carbide (SiC)

This material pairing is used where higher corrosion resistance is required. The high hardness of this material pairing offers good resistance against abrasive particles.

Secondary seal material: EPDM (ethylene-propylene rubber)

EPDM has excellent resistance to hot water. EPDM is not suitable for mineral oils.

A circulation of liquid through the duct of the air vent screw ensures lubrication and cooling of the shaft seal.

Twin-head pumps installed in horizontal pipes must be fitted with an automatic air vent in the upper part of the pump housing. The automatic air vent is not supplied with the pump.

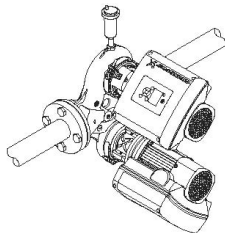

The motor stool forms connection between the pump housing and the motor, and is equipped with a manual air vent screw for venting of the pump housing and the shaft seal chamber. The sealing between motor stool and pump housing is an O-ring.

The central part of the motor stool is provided with guards for protection against the shaft and coupling. Motor and pump shaft are connected via a rigid sleeve coupling.



Company name: Hurley Engineering
Created by:
Phone:

Date: 2/28/2020

Count	Description
	<p>Motor</p> <p>The motor is a totally enclosed, fan-cooled motor with principal dimensions to IEC and DIN standards. Electrical tolerances comply with IEC 60034.</p> <p>The motor efficiency is classified as IE5 in accordance with IEC 60034-30-2. The motor requires no external motor protection. The motor control unit incorporates protection against slow- and quick-rising temperatures, e.g. constant overload and stalled conditions.</p> <p>The terminal box holds terminals for these connections:</p> <ul style="list-style-type: none">- one dedicated digital input- two analog inputs, 0(4)-20 mA, 0-5 V, 0-10 V, 0.5 - 3.5 V- 5 V voltage supply to potentiometer and sensor- one configurable digital input or open-collector output- Grundfos Digital Sensor input and output- 24 V voltage supply for sensors- two signal relay outputs (potential-free contacts)- the two power heads communicate via wireless GENIair or wired GENI connection- interface for Grundfos CIM fieldbus module. <p>Technical data</p> <p>Controls: Frequency converter: Built-in</p> <p>Liquid: Pumped liquid: Water Liquid temperature range: -13 .. 248 °F Selected liquid temperature: 68 °F Density: 62.29 lb/ft³</p> <p>Technical: Pump speed on which pump data is based: 3400 rpm Actual calculated flow: 188 US gpm Resulting head of the pump: 31.96 ft Actual impeller diameter: 3.54 in Code for shaft seal: BQQE Curve tolerance: ISO9906:2012 3B2</p> <p>Materials: Pump housing: Cast iron ASTM A48-40 B EN 1561 EN-GJL-250 Impeller: Composite PES/PP 30% GF</p> <p>Installation: Range of ambient temperature: -4 .. 122 °F Maximum operating pressure: PN 16 bar Type of connection: ANSI Pipe connection: DN 80 Pressure rating for pipe connection: PN 16 Port-to-port length: 14 3/16 in Flange size for motor: 56C</p>



Company name: Hurley Engineering
Created by:
Phone:

Date: 2/28/2020

Count	Description
	Electrical data:
	Motor type: 90C
	IE Efficiency class: IE5
	Rated power - P2: 2 x 2 HP
	Main frequency: 60 Hz
	Rated voltage: 3 x 440-480 V
	Rated current: 2.65 A
	Cos phi - power factor: 0.87
	Rated speed: 360-4000 rpm
	IE efficiency: 89.4%
	Motor efficiency at full load: 89.4 %
	Enclosure class (IEC 34-5): IP55
	Insulation class (IEC 85): F
	Motor Number: 99630348
	Others:
	DOE Pump Energy Index VL: 0.42
	ErP status: EuP Standalone/Prod.
	Net weight: 152 lb
	Gross weight: 181 lb
	Shipping volume: 8.83 ft ³



Company name: Hurley Engineering
Created by:
Phone:

Date: 2/28/2020

98817820 TPE2 D 80-150 N-A-G-A-BQQE-HCB 60 Hz

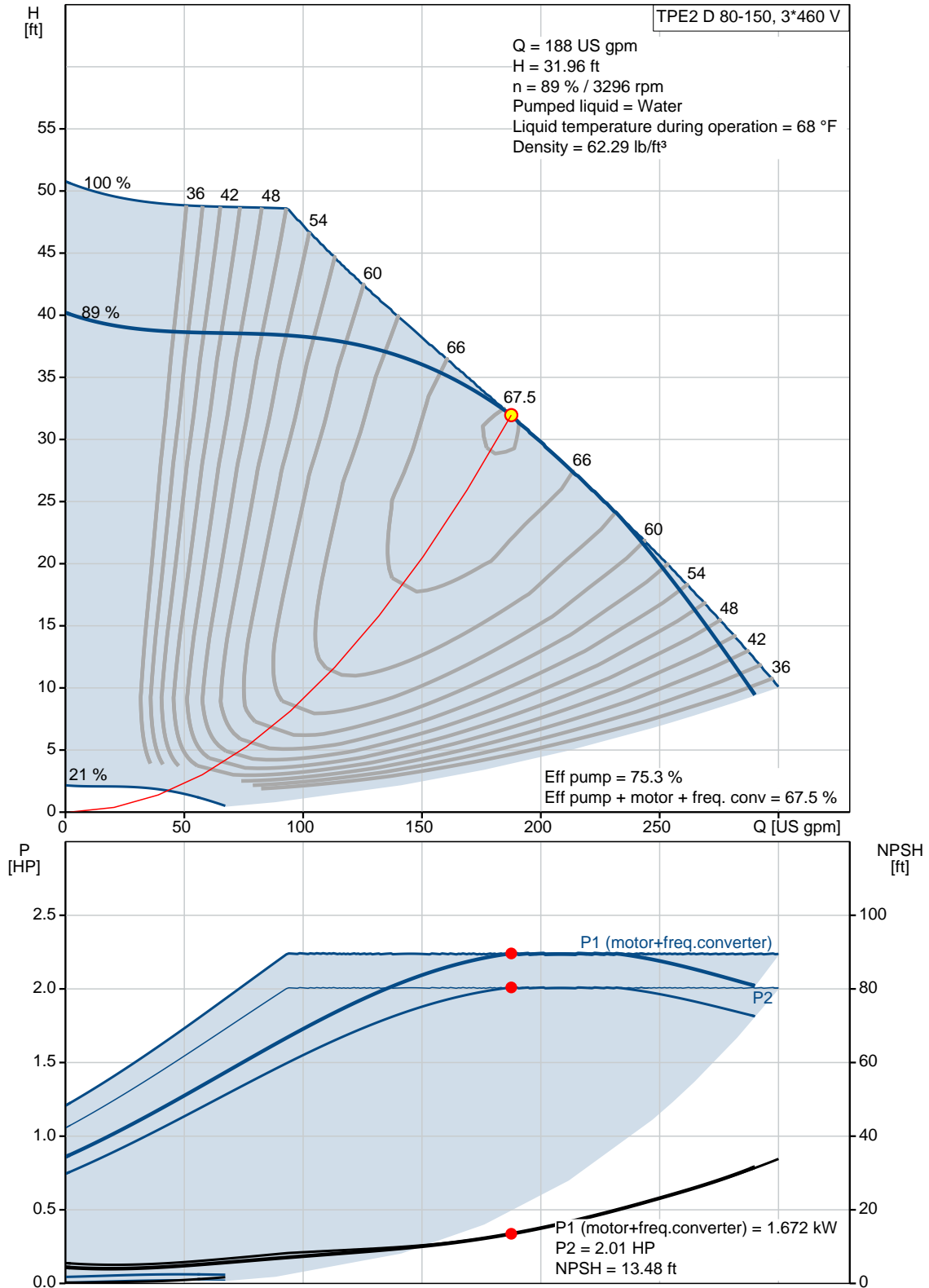

Description	Value
General information:	
Product name:	TPE2 D 80-150 N-A-G-A-BQQE-HCB
Product No.:	98817820
EAN:	5712601811958 5712601811958
Technical:	
Pump speed on which pump data is based:	3400 rpm
Actual calculated flow:	188 US gpm
Resulting head of the pump:	31.96 ft
Head max:	49.22 ft
Actual impeller diameter:	3.54 in
Code for shaft seal:	BQQE
Curve tolerance:	ISO9906:2012 3B2
Pump version:	A
Model:	A
Materials:	
Pump housing:	Cast iron ASTM A48-40 B EN 1561 EN-GJL-250
Impeller:	Composite PES/PP 30% GF
Material code:	A
Installation:	
Range of ambient temperature:	-4 .. 122 °F
Maximum operating pressure:	PN 16 bar
Type of connection:	ANSI
Pipe connection:	DN 80
Pressure rating for pipe connection:	PN 16
Port-to-port length:	14 3/16 in
Flange size for motor:	56C
Connect code:	G
Liquid:	
Pumped liquid:	Water
Liquid temperature range:	-13 .. 248 °F
Selected liquid temperature:	68 °F
Density:	62.29 lb/ft³
Electrical data:	
Motor type:	90C
IE Efficiency class:	IE5
Rated power - P2:	2 x 2 HP
Main frequency:	60 Hz
Rated voltage:	3 x 440-480 V
Rated current:	2.65 A
Cos phi - power factor:	0.87
Rated speed:	360-4000 rpm
IE efficiency:	89.4%
Motor efficiency at full load:	89.4 %
Enclosure class (IEC 34-5):	IP55
Insulation class (IEC 85):	F

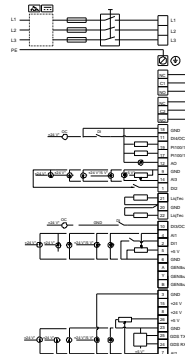
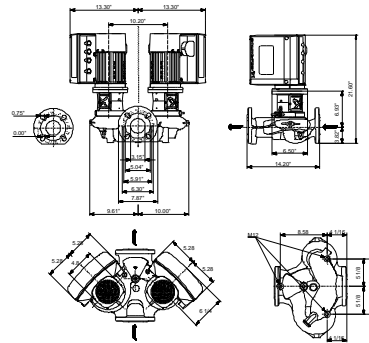
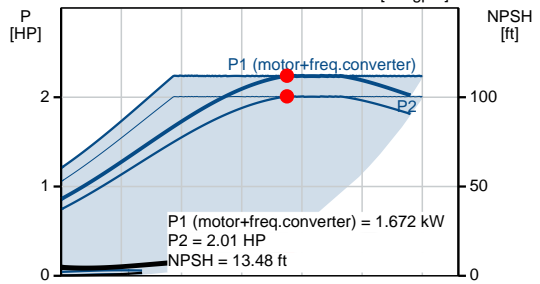
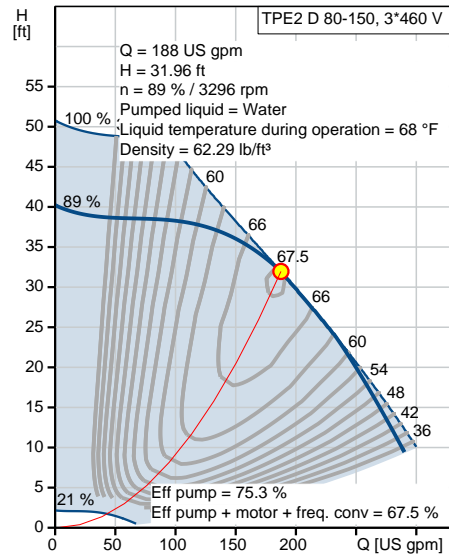



Company name: Hurley Engineering
Created by:
Phone:

Date: 2/28/2020

Description	Value
Motor protection:	YES
Motor Number:	99630348
Controls:	
Control panel:	HMI300 - Graphical
Function Module:	FM300 - Advanced
Frequency converter:	Built-in
Others:	
DOE Pump Energy Index VL:	0.42
ErP status:	EuP Standalone/Prod.
Net weight:	152 lb
Gross weight:	181 lb
Shipping volume:	8.83 ft ³
Config. file no:	98819269

98817820 TPE2 D 80-150 N-A-G-A-BQQE-HCB 60 Hz

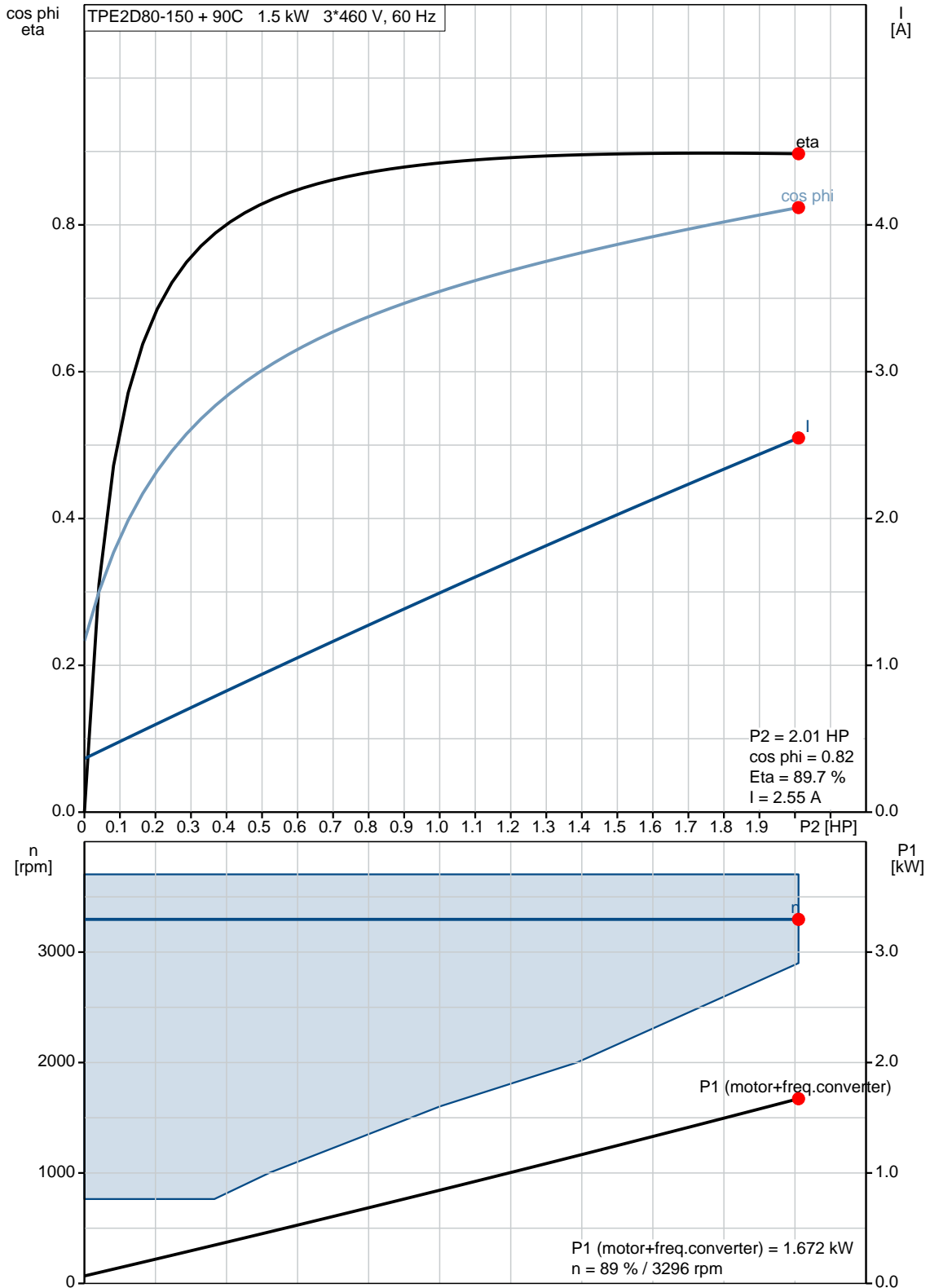

98817820 TPE2 D 80-150 N-A-G-A-BQQE-HCB 60 Hz

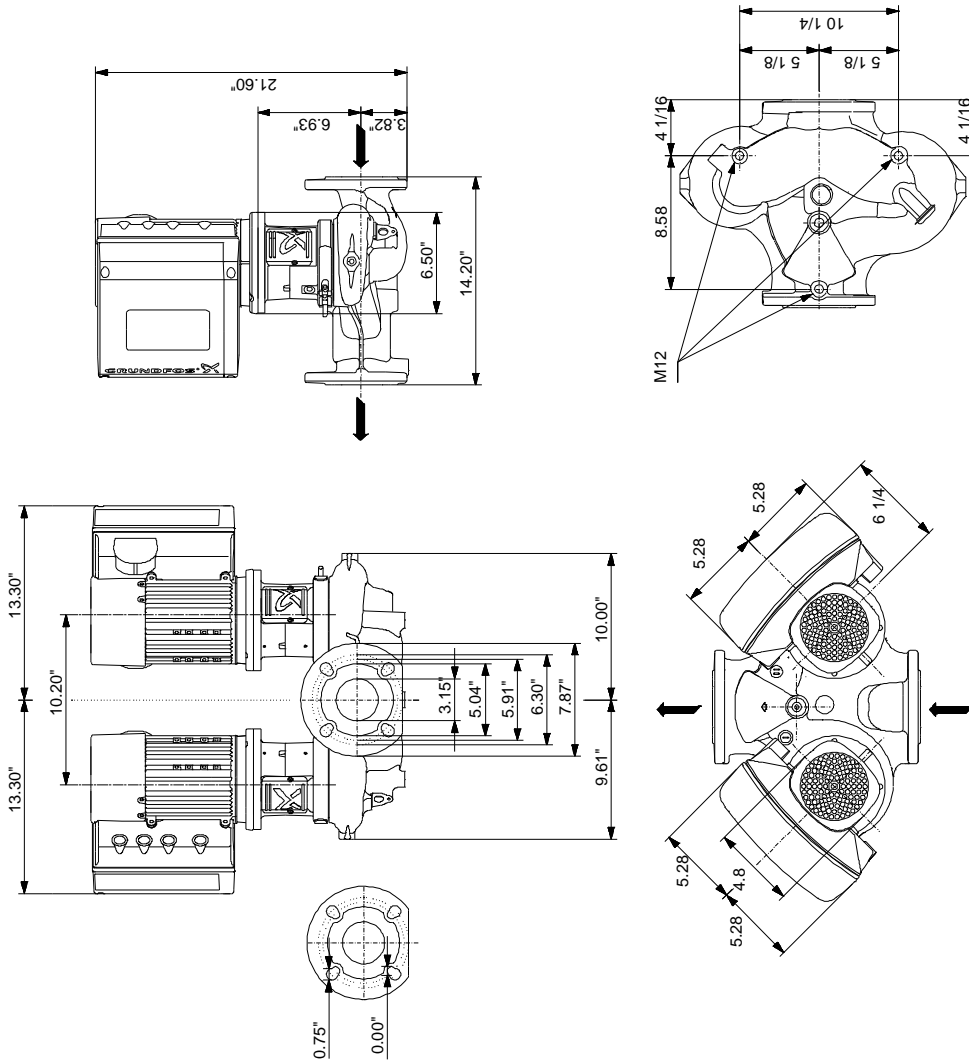

Note! All units are in [in] unless otherwise stated.
 Disclaimer: This simplified dimensional drawing does not show all details.

98817820 TPE2 D 80-150 N-A-G-A-BQQE-HCB 60 Hz

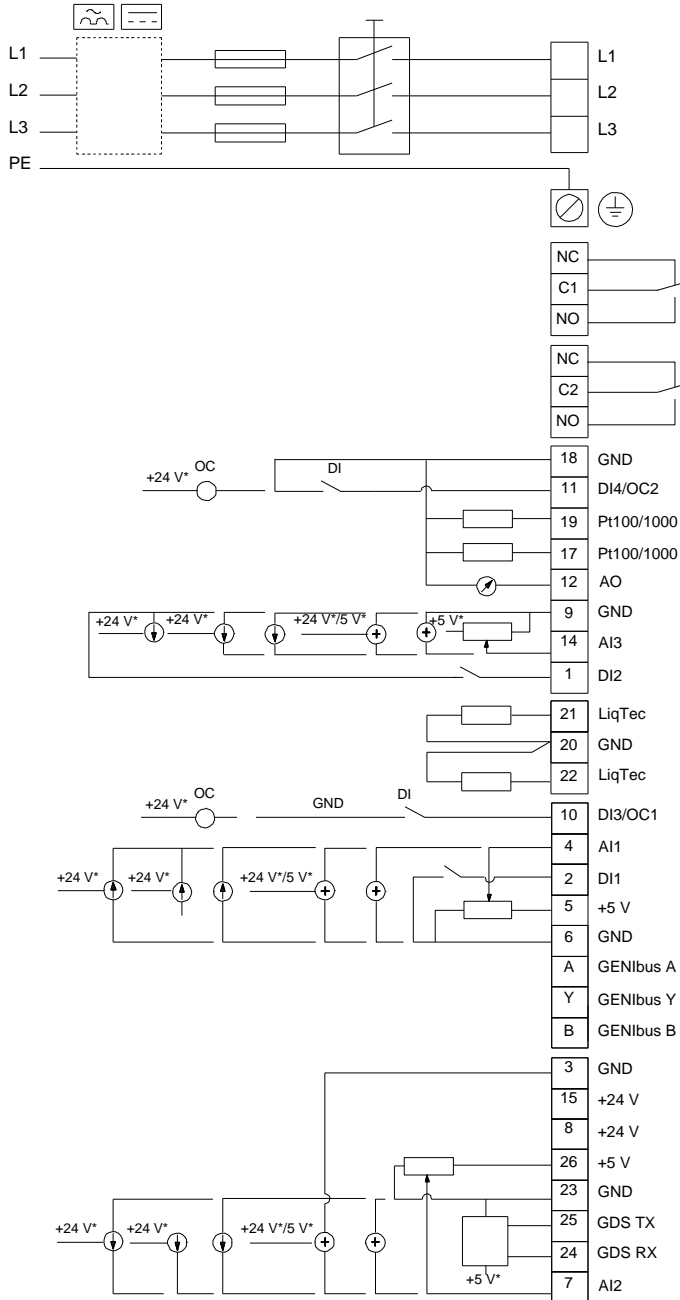

All units are [in] unless otherwise presented.



Company name: Hurley Engineering
Created by:
Phone:

Date: 2/28/2020

Order Data:

Product name: TPE2 D 80-150 N-A-G-A-BQQE-HCB
Amount: 1
Product No.: 98817820

Total: Price on request
