

PROJECT:	Magna-3	UNIT TAG:	_____	QUANTITY:	1
REPRESENTATIVE:	Hurley Engineering	TYPE OF SERVICE:	Stainless Steel Pump Configuration	DATE:	_____
ENGINEER:	TBD	SUBMITTED BY:	Devin Carle	DATE:	_____
CONTRACTOR:	TBD	APPROVED BY:	_____	DATE:	_____
		ORDER NO.:	_____	DATE:	_____

MAGNA3 50-80 F N



Full range of intelligent, high-efficiency circulators for heating, cooling, ground source heat pump systems and domestic hot water applications

Product photo could vary from the actual product

Conditions of Service		Pump Data		Motor Data	
Flow:	69.9 US gpm	Maximum operating pressure:	174.05 psi	P1 max:	18.5 .. 341 W
Head:	16.01 ft	Liquid temperature range:	14 .. 230 °F	Rated voltage:	115 V
Efficiency:	60.9 %	Maximum ambient temperature:	104 °F	Main frequency:	60 Hz
Liquid:	Water	Approvals:	98544604	Enclosure class:	X4D
Temperature:	140 °F	Flange standard:	GF	Insulation class:	F
NPSH required:	ft	Pipe connection:	GF53		
Viscosity:	_____	Product number:	98126814		
Specific Gravity:	0.985				

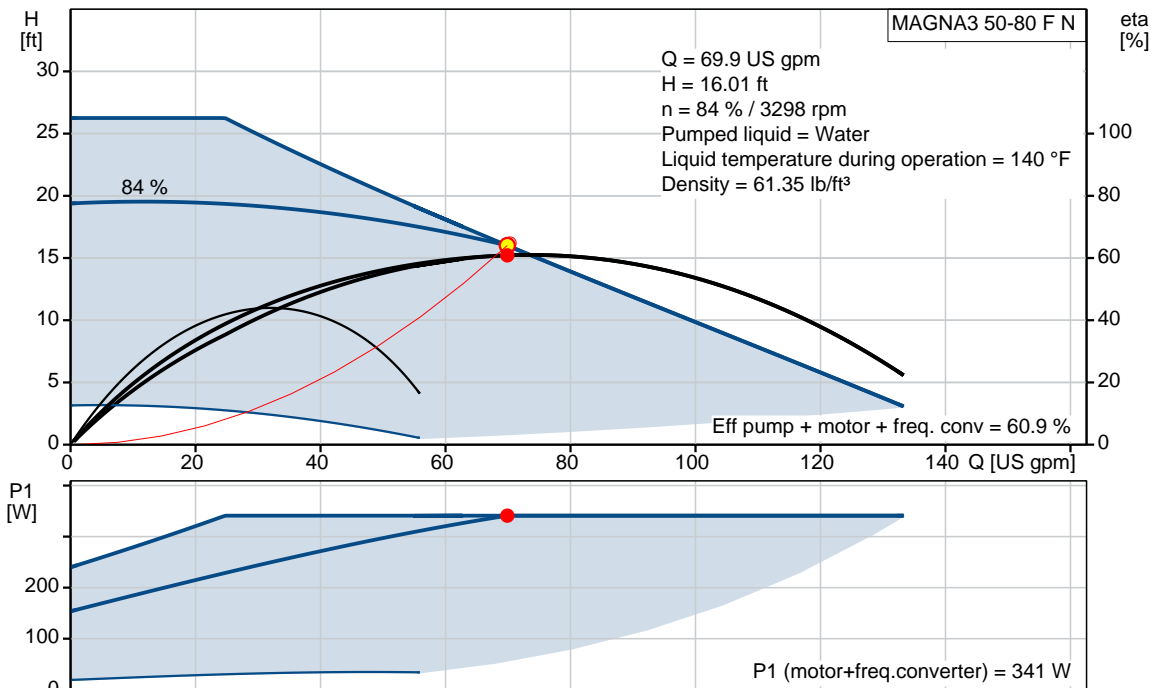

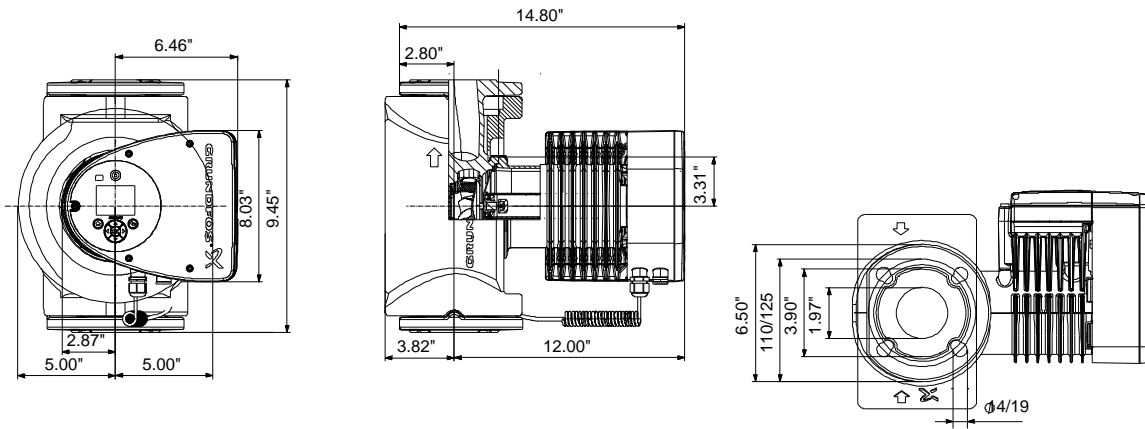

Materials:

Pump housing: Stainless steel
 EN 1.4308
 ASTM 351 CF8

Impeller: PES 30%GF

Count	Description
1	<p data-bbox="288 405 528 441">MAGNA3 50-80 F N</p> <div data-bbox="379 521 603 667" data-label="Image"> </div> <p data-bbox="288 734 568 763">Product No.: 98126814</p> <p data-bbox="288 792 1372 902">MAGNA3 – More than a pump With its unrivalled efficiency, all-encompassing range and built-in communication capabilities plus functionalities replacing system components, the MAGNA3 is ideal for engineers and specifiers looking to create high-performance systems for buildings.</p> <p data-bbox="288 909 1337 965">This pump in the Grundfos Master Class will fit both heating and cooling applications perfectly, making it the obvious choice for almost any building project – old or new.</p> <p data-bbox="288 996 1362 1137">The MAGNA3 is of the canned-rotor type, i.e. pump and motor form an integral unit without shaft seal and with only two gaskets for sealing. The bearings are lubricated by the pumped liquid. The innovative clamp with only one screw enables easy repositioning of the pump head. The MAGNA3 is a pump with no maintenance requirements and with extremely low Life Cycle Cost.</p> <p data-bbox="288 1169 890 1469">The pump is characterised by the following:</p> <ul data-bbox="288 1205 890 1469" style="list-style-type: none"> • controller integrated in the control box • control panel with TFT display on the control box • control box prepared for optional CIM modules • built-in differential-pressure and temperature sensor • cast-iron pump housing (depending on model) • carbon-fiber-reinforced composite rotor can • stainless-steel bearing plate and rotor cladding • aluminium alloy stator housing • air-cooled power electronics <p data-bbox="288 1469 724 1498">The MAGNA3 is a single-phase pump.</p> <p data-bbox="288 1529 552 1559">Characteristic features</p> <ul data-bbox="288 1559 1331 1939" style="list-style-type: none"> • AUTOADAPT. • FLOWADAPT and FLOWLIMIT (more than a pump function as it reduces the need for pump throttling valves). • Proportional-pressure control. • Constant-pressure control. • Constant-temperature control. • Constant-curve duty. • Max. or min. curve duty. • Automatic Night Setback. • No external motor protection required. • Insulating shells supplied with single-head pumps for heating systems. • Large temperature range where the liquid temperature and the ambient temperature are independent of each other. <p data-bbox="288 1971 916 2027">Communication The MAGNA3 enables communication via the following:</p>



Company name: Hurley Engineering
Created by:
Phone:

Date: 3/19/2020

Count	Description
	<ul style="list-style-type: none">• wireless Grundfos GO Remote• fieldbus communication via CIM modules• digital inputs• relay outputs• analog input (more than a pump function as heat energy meter) <p>Motor and electronic controller The MAGNA3 incorporates a 4-pole synchronous, permanent-magnet motor (PM motor). This motor type is characterised by higher efficiency than a conventional asynchronous squirrel-cage motor. The pump speed is controlled by an integrated frequency converter. A differential-pressure and temperature sensor is incorporated in the pump.</p> <p>Liquid: Pumped liquid: Water Liquid temperature range: 14 .. 230 °F Selected liquid temperature: 140 °F Density: 61.35 lb/ft³</p> <p>Technical: Actual calculated flow: 69.9 US gpm Resulting head of the pump: 16.01 ft TF class: 110 Approvals on nameplate: 98544604</p> <p>Materials: Pump housing: Stainless steel EN 1.4308 ASTM 351 CF8 Impeller: PES 30%GF</p> <p>Installation: Range of ambient temperature: 32 .. 104 °F Maximum operating pressure: 174.05 psi Flange standard: GF Pipe connection: GF53 Pressure stage: PN12 Port-to-port length: 9 1/2 in</p> <p>Electrical data: Power input - P1: 18.5 .. 341 W Main frequency: 60 Hz Rated voltage: 1 x 115 V Maximum current consumption: 0.31 .. 3.09 A Enclosure class (IEC 34-5): X4D Insulation class (IEC 85): F</p> <p>Others: Energy (EEI): 0.19 Net weight: 42.5 lb Gross weight: 47.1 lb Shipping volume: 1630 ft³ Country of origin: US Custom tariff no.: 8413.70.2005</p>



Company name: Hurley Engineering
Created by:
Phone:

Date: 3/19/2020

98126814 MAGNA3 50-80 F N 60 Hz

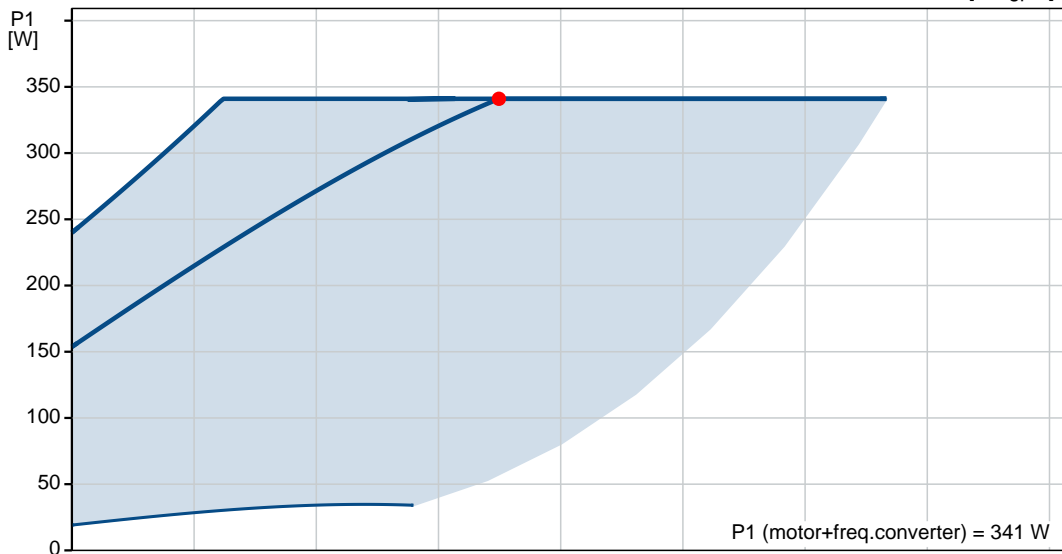
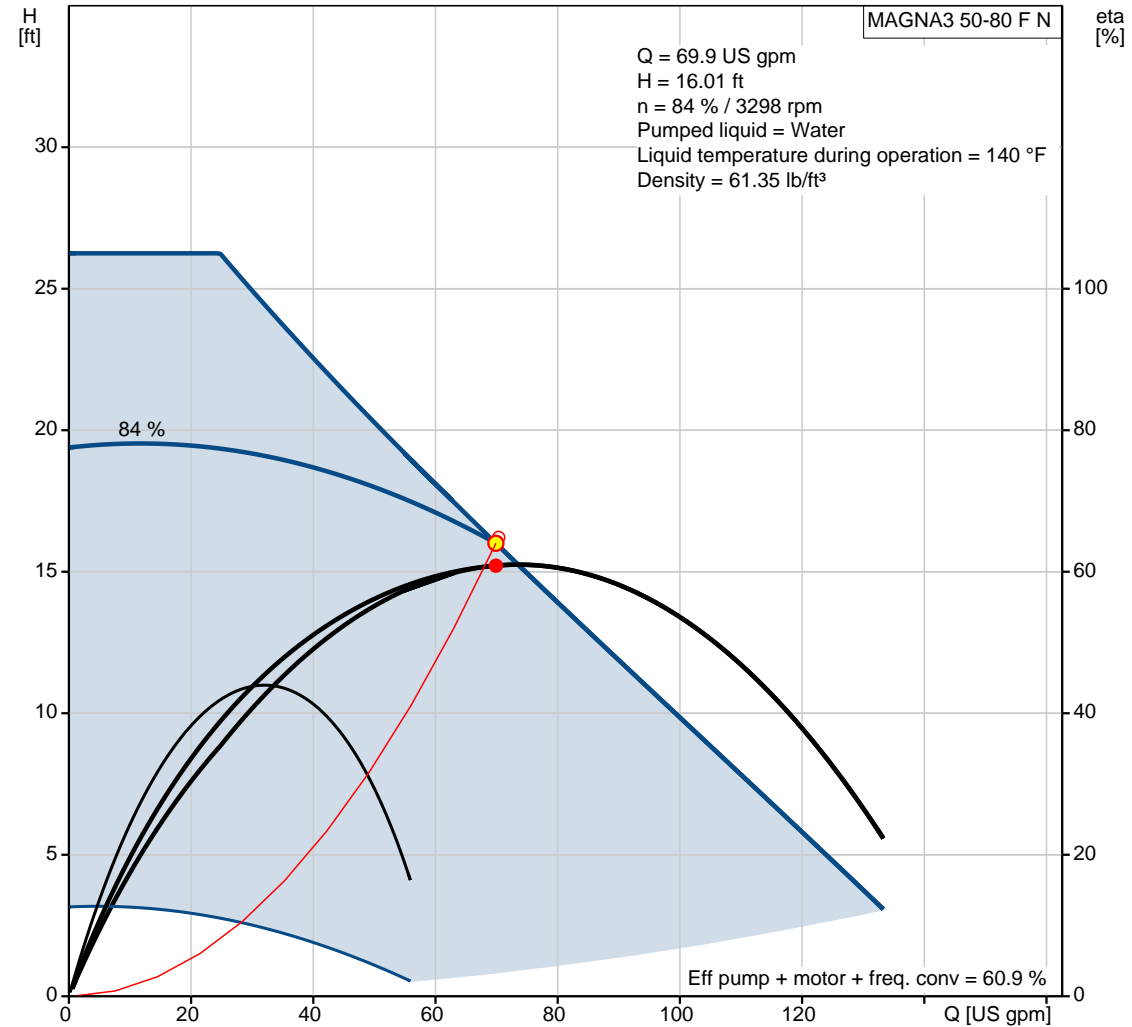

Description	Value
General information:	
Product name:	MAGNA3 50-80 F N
Product No.:	98126814
EAN:	5710629499769
	5710629499769
Technical:	
Actual calculated flow:	69.9 US gpm
Resulting head of the pump:	16.01 ft
Head max:	26.25 ft
TF class:	110
Approvals on nameplate:	98544604
Model:	D
Materials:	
Pump housing:	Stainless steel EN 1.4308 ASTM 351 CF8
Impeller:	PES 30%GF
Installation:	
Range of ambient temperature:	32 .. 104 °F
Maximum operating pressure:	174.05 psi
Flange standard:	GF
Pipe connection:	GF53
Pressure stage:	PN12
Port-to-port length:	9 1/2 in
Liquid:	
Pumped liquid:	Water
Liquid temperature range:	14 .. 230 °F
Selected liquid temperature:	140 °F
Density:	61.35 lb/ft ³
Electrical data:	
Power input - P1:	18.5 .. 341 W
Main frequency:	60 Hz
Rated voltage:	1 x 115 V
Maximum current consumption:	0.31 .. 3.09 A
Enclosure class (IEC 34-5):	X4D
Insulation class (IEC 85):	F
Others:	
Energy (EEI):	0.19
Net weight:	42.5 lb
Gross weight:	47.1 lb
Shipping volume:	1630 ft ³
Country of origin:	US
Custom tariff no.:	8413.70.2005

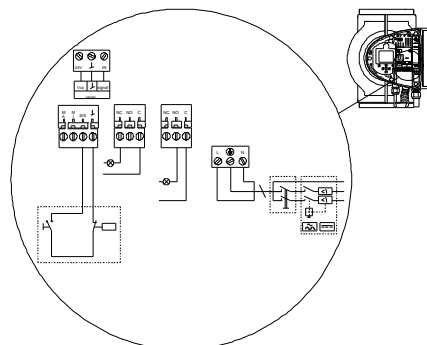
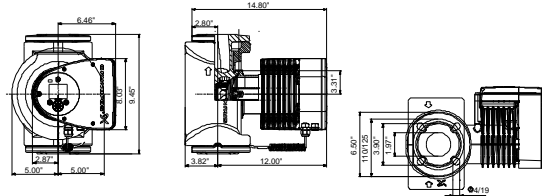
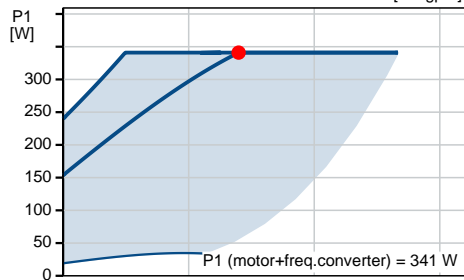
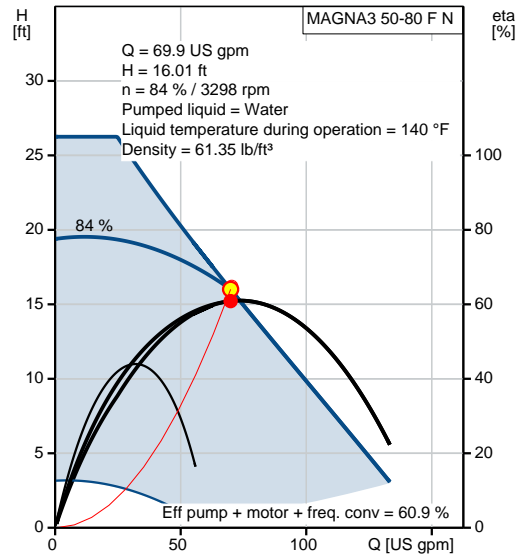



Company name: Hurley Engineering
Created by:
Phone:

Date: 3/19/2020

98126814 MAGNA3 50-80 F N 60 Hz

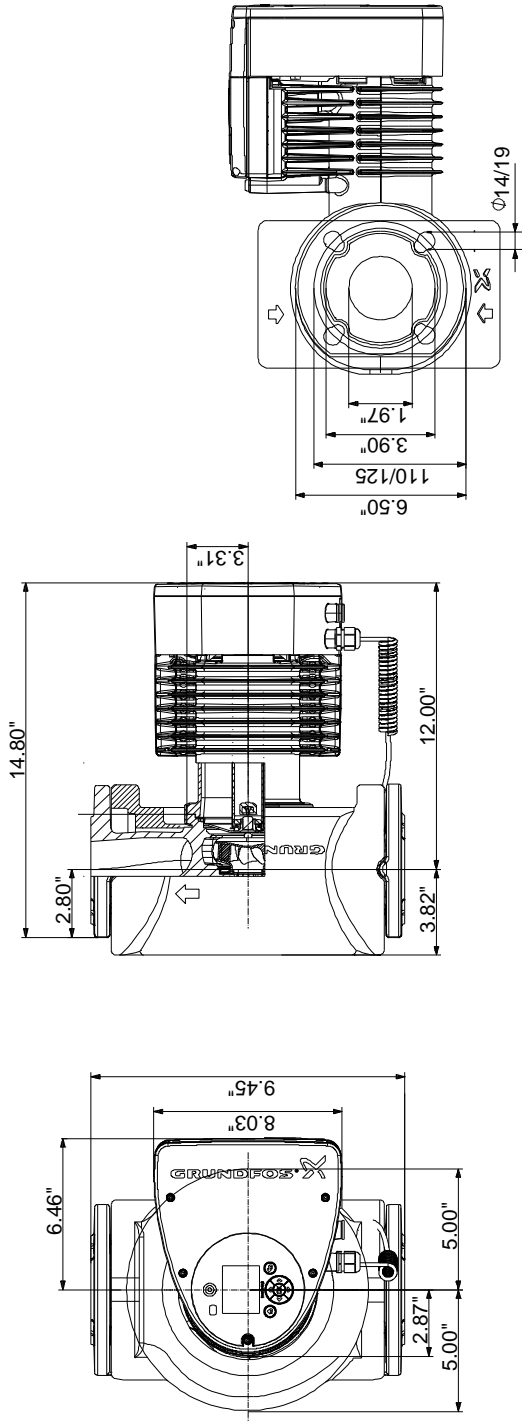

Note! All units are in [in] unless otherwise stated.
Disclaimer: This simplified dimensional drawing does not show all details.

98126814 MAGNA3 50-80 F N 60 Hz

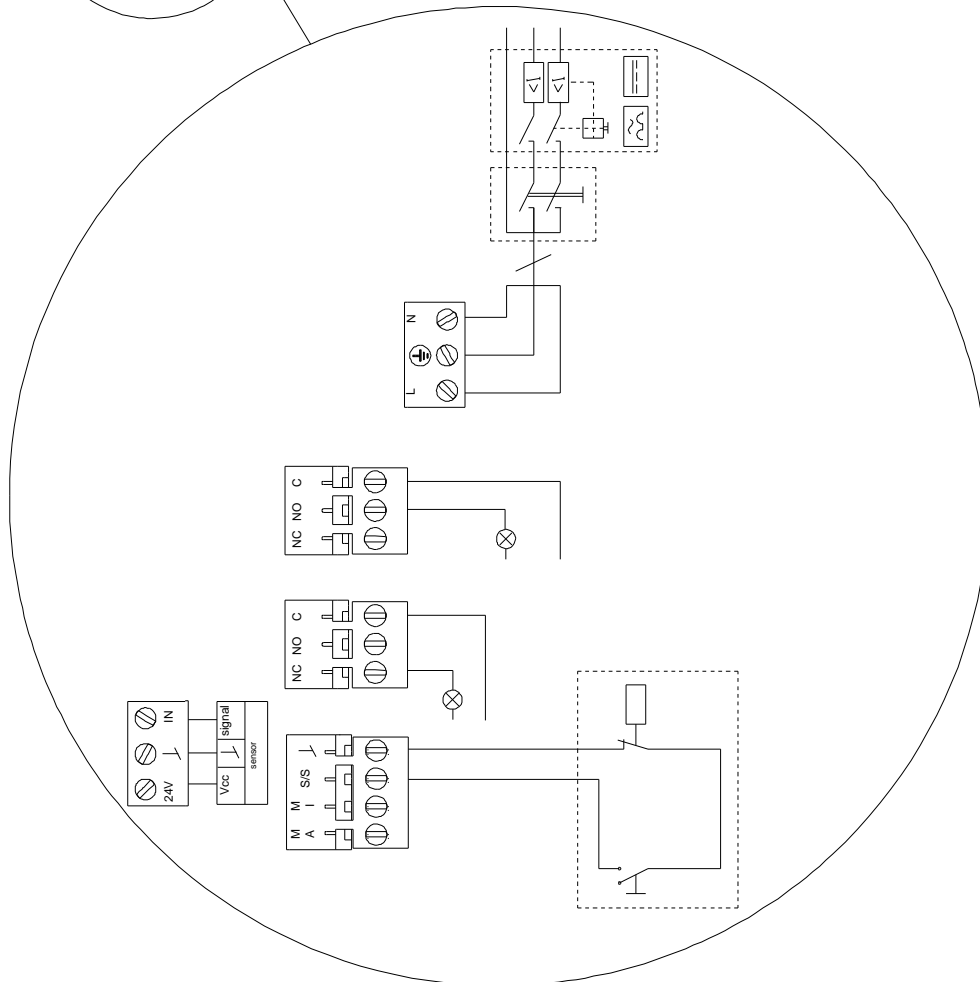
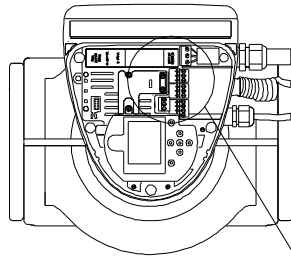

All units are [in] unless otherwise presented.