



Alfa Laval AQ3

AlfaQ™ AHRI-certified plate heat exchanger

Application

The Alfa Laval industrial line of plate heat exchangers is well suited for a wide range of heating and cooling duties.

Benefits

- High serviceability - Easy to open
- Compact design
- Easy to install
- Flexible heat transfer area configuration
- High energy efficiency - Low operating cost

Design

The plate heat exchanger consists of a package of corrugated metal plates with portholes for the passage of the two fluids between which heat transfer will take place.

The number of plates is determined by the flow rates, physical properties of the fluids, pressure drops and temperature program. The plate corrugations promote fluid turbulence and support the plates against differential pressure.

The materials of gaskets are selected for safe use depending on media type and temperature. The attachment of the gasket rings is glue-free, which makes them easy to replace even with the plates still hanging in the frame.

The carrying bar and guiding bar are fixed to the stationary frame plate and the supporting column. The pressure plate and plate package is movable along the upper carrying bar and located by the lower guiding bar. Connections are located in the frame plate. Depending on the application, connections can also be located in the pressure plate.



Working principle

Channels are formed between the plates and the corner ports are arranged so that the two media flow through alternate channels. The heat is transferred through the plates between the channels. Complete counter-current or co-current flow, depending on the application, is created for highest possible efficiency. The corrugation of the plates provides the passage between the plates, supports each plate against the adjacent one and enhances the turbulence, resulting in efficient heat transfer.

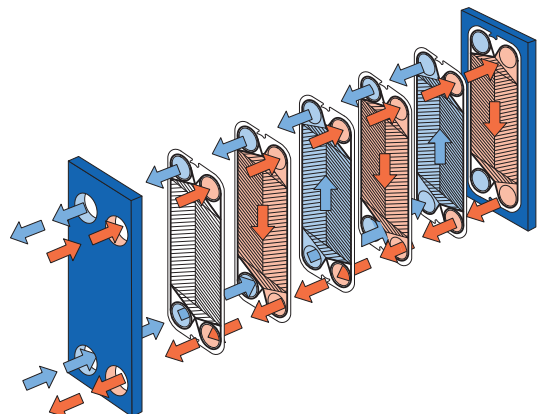

Flow principle of a plate heat exchanger.

STANDARD MATERIALS

Frame plate

Mild steel, epoxy painted

Connections

Metal lined: Stainless steel and Titanium.

Rubber lined: Nitrile (FM only)

Plates

Stainless steel Alloy 304, Alloy 316 and Titanium

Gaskets

Field gaskets: Nitrile, EPDM

Ring gaskets: Nitrile, EPDM

Other grades and materials available upon request.

TECHNICAL DATA

Design pressure (g)

FM	pvcALS™	1.034 MPa
FM	PED	1.034 MPa
FG	pvcALS™	1.60 MPa
FG	PED	1.60 MPa
FG	ASME	150 psi

Design temperature

Determined by gasket material.

Plate types

AQ3-B and AQ3-M

Connection size

DN80 / NPS 3 / 80A

Maximum heat transfer surface

35 m² (377 sqft)

Maximum liquid flow rates

Up to 30 kg/s (475 gpm), depending on media, permitted pressure drop and temperature program.

Connection standard

FM	pvcALS™	EN 1092-1 PN10, ASME B16.5 Class 150, JIS B2220 10K
FM	PED	EN 1092-1 PN10, ASME B16.5 Class 150
FG	pvcALS™	EN 1092-1 PN16 and PN10, ASME B16.5 Class 150, JIS B2220 16K and 10K
FG	PED	EN 1092-1 PN16, ASME B16.5 Class 150
FG	ASME	ASME B16.5 Class 150

Standard EN 1092-1 corresponds to GOST 12815-80 and GB/T 9115.

Particulars required for quotation

To receive a quotation for plate heat exchangers that meet your requirements, please provide Alfa Laval representatives with:

- Flow rates or heat load
- Temperature program
- Physical properties of liquids in question (if not water)
- Design pressure and design temperature
- Maximum permitted pressure drop

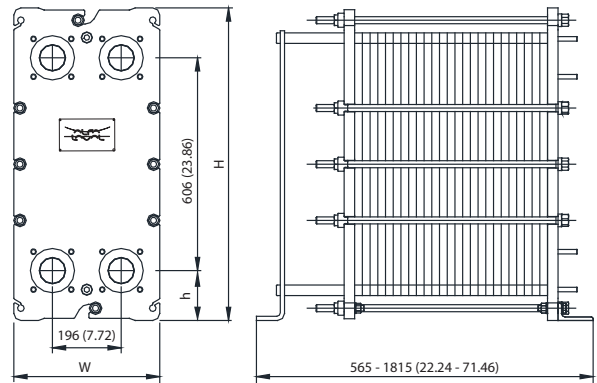

Measurements mm (inch)

Type	H	W	h
AQ3-FM (ALS,PED,ASME)	890 (35.04)	400 (15.78)	142 (5.59)
AQ3-FG (ALS,PED)	890 (35.04)	400 (15.78)	142 (5.59)
AQ3-FG (ASME)	890 (35.04)	416 (16.38)	142 (5.59)

The number of tightening bolts may vary depending on type.

The thermal performance is third party certified through the AHRI Liquid to Liquid Heat Exchangers certification program



How to contact Alfa Laval

Up-to-date AlfaLaval contact details for all countries are always available on our website on www.alfalaval.com