



BCT-62-102G

BCT-62-102G

Double Stack Gas
Combination-Oven/Steamer with
Touchscreen Control



Project _____

Item No. _____

Quantity _____

- Standard pan cassette with 3.35" (85mm) spacing holds 13 sheet pans or 26 North American hotel pans
- Optional pan cassette with 2.56" (65mm) spacing holds 16 sheet pans or 32 Gastronorm pans

Refer to operator manual specification chart for listed model names.

CONSTRUCTION

- 304 stainless steel exterior and interior
- Dual pane tempered viewing window with hinged inner glass for easy cleaning
- 2" (50mm) fixed drain in the bottom center of cavity
- Door mounted drip tray reduces the risk of wet, slippery floors
- Automatic door stops in positions of 110° and 180°
- Left hinge door is field convertible to the right side (with the purchase of conversion kit)
- Two step safety door latch. The first step stops the fan.

OPERATION

- Built in steam generator produces pure, dry steam
- Automatic boiler flushing system
- Easy to use touchscreen control
- Multiple cooking modes include hot air, CombiSmart, CombiOptima, retherm, steaming, low-temperature steaming, forced steaming, proofing, preheating
- Stores up to 500 recipes with up to 15 steps each
- Manual or automatic cooling
- Automatic humidity pulsing
- External core temperature probe
- Rack timing allows for setting individual timers for each rack
- Reversible 9 speed fan for optimum baking and roasting results
- USB port for data and recipe transfer
- HACCP recording and documentation
- Automated CombiWash, closed circuit cleaning system features very low water and detergent consumption and no contact with chemicals. No proprietary chemicals required, see owner's manual for detergent guidelines.
- Semi automatic deliming system

STANDARD FEATURES

- Cassette support platform
- External core temperature probe with multiple measuring points.
- Bright halogen lights for superior visibility
- Stand with casters
- Built in hand shower
- Removeable cleaning chemical bottle shelf
- 5 wire shelves per section
- Start-up inspection service by factory authorized service agent
- One year parts and labor oven warranty*

* For all international markets, contact your local distributor.

OPTIONS AND ACCESSORIES

(AT ADDITIONAL CHARGE)

- Additional core probe
- Heat shield
- Wire oven rack
- Right hinge door
- Backflow preventer
- Extra year warranty

OPTIONS AND ACCESSORIES

(AT NO CHARGE)

- Optional pan cassette with 2.56" (65mm) spacing
- Legs in lieu of casters



BLODGETT OVEN COMPANY

www.blodgett.com • 42 Allen Martin Drive, Essex Junction, VT 05452 • Phone: (802) 658-6600 • Fax: (802) 864-0183



BCT-62-102G

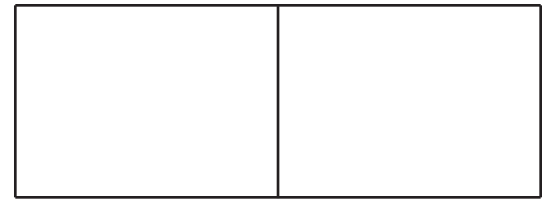

APPROVAL/STAMP

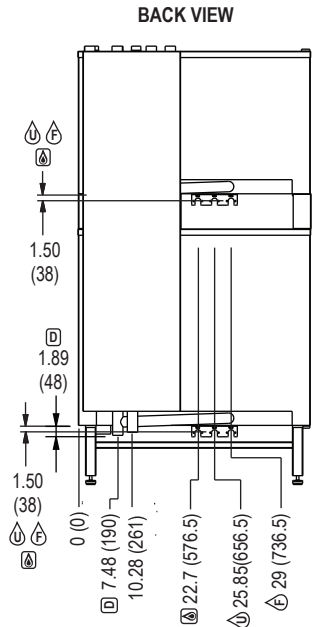
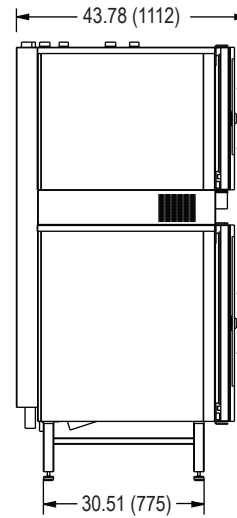
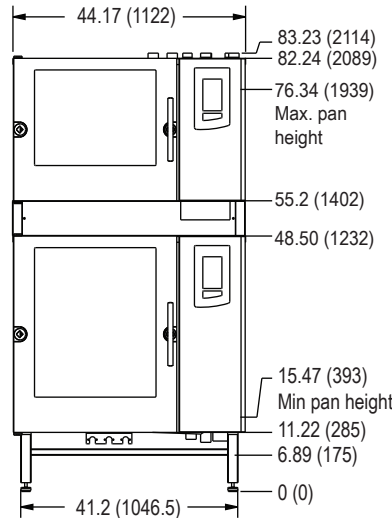
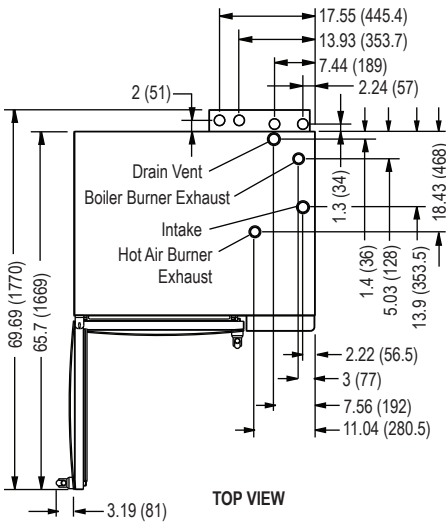

LEGEND	
	ELECTRICAL
	FILTERED WATER
	GAS
	UNFILTERED WATER
	DRAIN

DIMENSIONS ARE IN INCHES (MM)

SHORT FORM SPECIFICATIONS: Provide Blodgett Combi model BCT-62/102G combination-oven/steamer. The BCT-62/102G has a pan cassette with 3.35" (85mm) rack spacing that holds 13 sheet pans or 26 North American hotel pans. The optional pan cassette with 2.5" (65mm) spacing holds 16 sheet pans or 32 Gastronorm pans. Unit shall have 304 stainless steel exterior and interior. Oven door shall have dual pane tempered viewing window with hinged inner glass for easy cleaning. Unit shall have the ability to cook with pressureless steam, hot air, or combination of steam and hot air. Steam generator shall be separate from the cooking compartment and shall drain and flush automatically. Multiple modes include hot air, combi with CombiOptima, retherming, steaming, low-temperature steaming, forced steaming, proofing, cooling, and preheating. Unit shall have bright halogen lights for superior visibility. Touchscreen control stores 500 recipes with 15 stages each, in addition to pre-programmed recipes. External core temperature probe, rack timing allows for setting individual timers for each rack, HACCP quality control, USB connectivity, automatic service diagnosis. The reversible 9 speed fan provides optimum baking and roasting results. Automated CombiWash, closed circuit cleaning system features very low water and detergent consumption and no contact with chemicals. Semi automatic delimiting system. One-year parts and labor warranty. Provide start-up inspection service by a factory authorized service agent. Provide options and accessories as indicated.

DIMENSIONS:

Floor space: 44.17" x 43.78" (1122 x 951mm)
Unit height: 83.23 (2114mm)

OVEN CLEARANCES:

From combustible and non-combustible construction

Right 4" (102mm)
 Left 0" (0mm)
 Back 2" (50mm)

Blodgett recommends and 12" (305mm) be maintained on the control side for servicing.

MINIMUM ENTRY CLEARANCE (per section):

Uncrated 37.44" (951mm)
 Crated 38" (965mm)

GAS SUPPLY (per section):

3/4" NPT

Inlet Pressure:

Natural 3.2-8.0" W.C. static to unit
 Propane 5.2-14" W.C. static to unit

Maximum Input:

BCT-62G 80,000 BTU/hr
 BCT-102G 90,000 BTU/hr

NOTE: The company reserves the right to make substitutions of components without prior notice

POWER SUPPLY (per section):

115 VAC, 1 phase, 9 amps

Blodgett recommends a Pass & Seymour, model 2097, GFCI due to the use of a variable frequency drive. Must be hard wired in some cases.

WATER SUPPLY & DRAIN:

Good quality water feed is the responsibility of the owner. Water quality must be within the following general guidelines.

TDS: 40-125 ppm Hardness: 35-100 ppm pH: 7.0 - 8.5
 Silica: <13 ppm Chlorides: <25 ppm Chlorine: <0.2 ppm
 Chloramine: <0.2 ppm

The best defense against poor water quality is a water treatment system designed to meet your water quality conditions. Blodgett offers optional systems from Optipure.

Pressure: 40(min)-50(max) PSI

Connections: 2" drain connection - max. drain temperature 140°F (60°C)
 3/4" garden hose cold water

The drain piping must consist of temperature resistant material, greater than 160°F, and be of adequate diameter not to cause flow restriction. Improper materials may deform and cause restrictions, thus affecting performance.

Appliance is to be installed with backflow protection in accordance with federal, state or local codes.

SHIPPING INFORMATION:

Approx. weight: 1045 lbs. (474 kg)