



A WCS Group Company



**KINGFISHER
ENVIRONMENTAL
SERVICES LTD**
A WCS Group Company



Clearwater
A WCS Group Company

CHLORINE DIOXIDE GENERATORS (ClO₂IX)

Proven new-generation

No storage of ClO₂

Safe - no chemicals are mixed

Reliable ClO₂IX generation

No dangerous by-products

Dilute, high quality solution

Dispenses 700mg/L low concentration solution without storage

Self-monitoring / correcting

Suitable for...

Biofilm eradication

Legionella control

Membrane systems

Water distribution systems

Cooling towers

Hospitals

Hotels

Horticulture

Breweries

Dairies

Food processing

Universities

Acid restriction sites

And more ...

CHLORINE DIOXIDE GENERATORS

Modern-day chlorine dioxide water treatment using ClO₂IX offers distinct advantages.

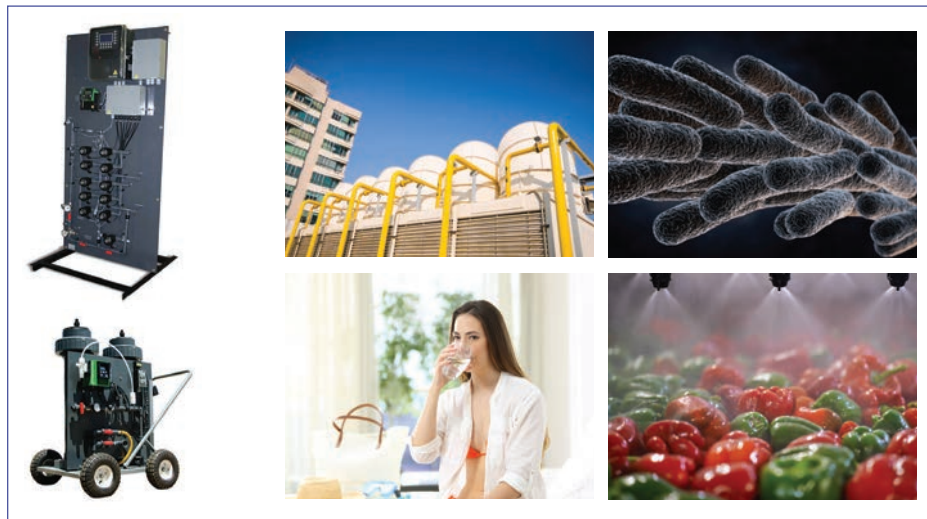

ClO₂ – an effective, low concentration water disinfectant

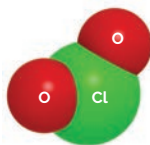

ClO₂IX is a tech-enabled chlorine dioxide solution that contains no chlorine, no ozone, has a high conversion rate (>75%), produces low concentration levels, is high purity (>98.5%), generated in a controlled reaction that is extremely safe, with no storage of ClO₂ because it is generated ON DEMAND.

Beneficial properties of ClO₂

- Effective over pH range of 2 – 10
- Doesn't produce THMs
- Reacts with odour-causing compounds
- Breaks down phenols
- Precipitates iron and manganese
- Can overcome organic loading
- Penetrates and destroys biofilm
- Potable and process water

Conventional ClO₂ generation negatives

- Hard to make and storage is a problem
- UV light, heat and time degrade it
- Chemical mixing generators create by-products, can be corrosive, produce low yield, require accurate dosing
- Electromechanical generators suffer poor conversion, require complex pre-treatment, are maintenance heavy, require accurate dosing

Introducing new generation, proven ClO₂IX chlorine dioxide generators

Solves all of the problems and perceived limitations of conventional ClO₂ generation and come in a range of models to provide 5KG to 90+KG/day of ClO₂.



Why is ClO₂IX better?

ClO₂IX is a tech-enabled chlorine dioxide solution that contains no chlorine, no ozone, has a high conversion rate, uses low concentration levels, produces low concentration solution, high purity ClO₂, generated on a controlled reaction that is extremely safe, with no storage because it is generated ON DEMAND.

How it works

ClO₂ is made through the formation of chlorous acid. The ClO₂IX systems produce a solution of chlorous acid without residual Na⁺ by using a special cation exchange resin in the H⁺ form. This removes the Na⁺ from sodium chlorite and replaces it with H⁺ to form pure chlorous acid.

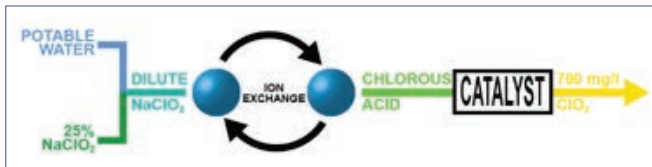

Once chlorous acid is formed, the reaction to ClO₂ can commence. Using catalytic technology, the ClO₂IX generator converts almost instantaneously (>98.5%) of the chlorous acid to ClO₂. The resultant 700 mg/l ClO₂ or Chlorate product contains no chlorine, no ozone and virtually no chlorite. Because of the ability for the ClO₂IX system to dispense continuously on demand rather than batch

process (it is a duplex system), high quality, low concentration ClO₂ is produced on demand, reliably.

Key system advantages

- Virtually zero chlorite and chlorate by-products in generation
- Super reliable chlorous acid generation
- Special catalytic technology in the Conversion Cartridge is more reliable, far quicker, safer and more efficient than older ClO₂ generator technology
- No excess acid is generated
- No chemical mixing is needed
- No electrochemistry is used
- ClO₂IX can be dosed proportionally into the process water
- ClO₂IX generators operate under pressure (pressurized line dosing enabled)
- Safer ClO₂ concentrations of less than 700 mg/l are produced with no need for storage

Attractive features

- From 0.1 to 120g/day of ClO₂
- Regenerable or Refillable IX
- Ideally suited for continuous production of ClO₂
- Better for RO plants because pinholes are not created in membranes
- Precursor and ClO₂ occurs in water and only when water flows through the system
- Reliable monitoring and self-correction is built-in
- Rugged construction and components
- Permanent or mobile solution
- Emergency incident solution or flushing aid
- Finance available inclusive of first year's maintenance

Common applications

Water distribution and Re-Use

All commercial and industrial sites where precise microbiological purity point-of-use water disinfection is required. Includes potable and process water. Includes water purification and water re-use.

Process water, especially in food production

Reliable, high purity water that can be recycled and re-used across multiple cycles minimising discharge and drawing of more expensive mains-water.

Rinsing and washing stations

Especially important where no taste, colour or residue is required and where hygiene has to be demonstrably maintained. Production plants wanting to re-use water and minimise drawing of more expensive mains-water.

Greenhouses and Horticulture

ClO₂IX does not react with the fertilisers commonly used in commercial greenhouses and horticulture. The ClO₂IX process produces a sodium-free product

that does not affect pH or reduce chelated iron. ClO₂IX is ideal for reuse irrigation water.

Hospitals and care homes

Immuno-compromised patients are more susceptible to waterborne pathogens and bacteria. ClO₂ is a widely recognised pathogen control methodology and ClO₂IX is an efficient, safe secondary disinfection option (especially relevant for sites with a no acid policy).

Hotels and Leisure

ClO₂ is a favoured disinfectant route for many hotel and leisure site operators because of the reliability of water purity, odour and taste considerations. ClO₂IX is also produced on demand, dosed in a weak concentration and continuously available.

Reverse Osmosis (RO) plants

ClO₂ produced by ClO₂IX systems is chlorine free, ozone free and will not attack TFC membranes. Cleaning cycles intermittently as the application requires.

and energy consumption can be reduced greatly by feeding <0.2 mg/l in to the RO feed water either continuously or intermittently as the application requires.

Closed water loops

ClO₂IX is ideal for chilled water loops to tackle contaminants and biofouling caused by system leaks, especially in large buildings. ClO₂IX is chlorine, corrosion and bromine-free and good for manual or auto dosing. Pace the feed of biocide using low dilution, pure 700 mg/l ClO₂IX. You can also shock-dose in to a sump tank. ClO₂IX is free of metal ions.

Water tanks (commercial, domestic system, agricultural)

ClO₂ is an ideal disinfectant for cold water storage tanks where low pressure may exist and where bacteria harbouring biofilm can thrive. Chlorine in incoming mains water may be insufficient to deal with biofilm. ClO₂IX can be an effective disinfectant to assist chlorine in mains water in protecting water safety and preventing biofilm regeneration once a tank is clean.



CLO₂IX INDUSTRIAL

45g to 90Kg of ClO₂
 Model Variants: 9
 Permanent plant
 Ion Exchange is Replaceable or Regenerated
 Supplied with Generator
 Ion Exchange Tank x 2
 Pre-Filter 10" housing 30 micron filter x 1
 Pre-Filter 10" housing 5 micron filter x 1
 Floor space (M): 1.11 x 1.11 x 1.88m (L x W x H)
 Generator Dimensions (M): 0.76 x 0.76 x 1.88 (W x D x H)
 Ion Exchange Tank Dimensions (M): 0.15 x 0.89 (Dia x L)
 Catalyst Cartridge has to be purchased SEPARATELY
 Lease finance available including Year 1 maintenance

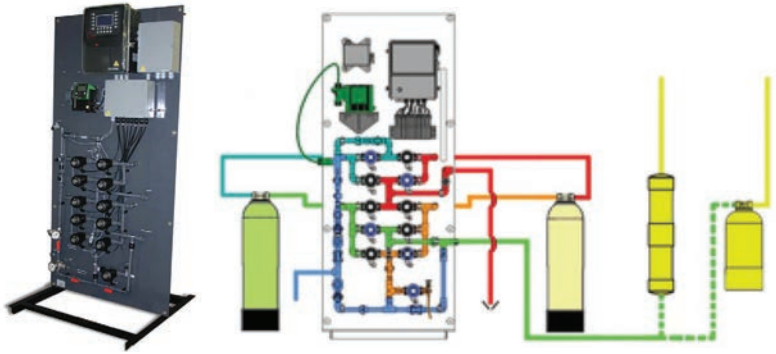

Inlet Potable Water

A potable water source is required for the system.

Sodium Chlorite

A 25% NaClO₂ solution is diluted with potable water such that the resulting concentration of NaClO₂ is 1,250 mg/L.

Chlorous Acid

The dilute NaClO₂ flows through the ion exchange vessels where the NaClO₂ is converted to HClO₂ through the exchange of the N⁺ in solution for the H⁺ on the cation resin.

Chlorine Dioxide

The HClO₂ is converted to dilute ClO₂ in the catalyst cartridge which produces a low concentration solution (700 mg/L).

Regeneration

The H⁺ ion in the regenerant acid forces the Na⁺ ion off of the exhausted cation resin. The system is a duplex system meaning that one cation vessel is converting NaClO₂ to HClO₂ the other vessel is in regeneration. When the system determines that the first vessel is exhausted, the system automatically switches sides so that HClO₂ production is not interrupted. To increase efficiency, the Impulse Regeneration Method is employed.

Drain

The waste regenerant containing the Na⁺ ions is flushed to drain as part of the regeneration process. The system also primes itself to drain.

CLO₂IX MINI

45g to 55Kg of ClO₂
 Model Variants: 1
 Permanent plant
 Ion Exchange is Replaceable or Regenerated
 Supplied with Generator
 Ion Exchange Tank x 2
 Pre-Filter 10" housing 30 micron filter x 1
 Pre-Filter 10" housing 5 micron filter x 1
 Floor space (M): 1.11 x 1.11 x 1.88m (L x W x H)
 Generator Dimensions (M): 0.76 x 0.76 x 1.88 (W x D x H)
 Ion Exchange Tank Dimensions (M): 0.15 x 0.89 (Dia x L)
 Catalyst Cartridge has to be purchased SEPARATELY
 Lease finance available including Year 1 maintenance

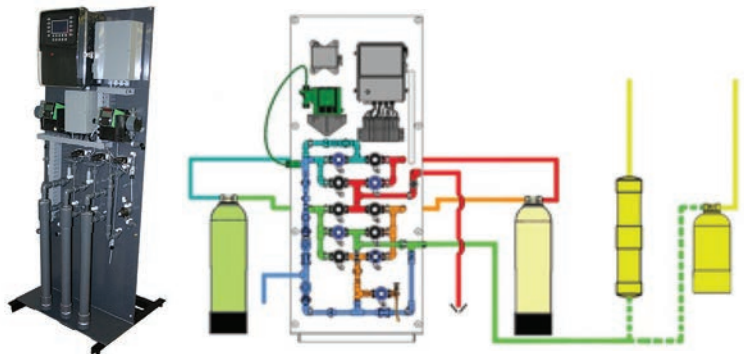

Inlet Potable Water

A potable water source is required for the system.

Sodium Chlorite

A 25% NaClO₂ solution is diluted with potable water such that the resulting concentration of NaClO₂ is 1,250 mg/L.

Chlorous Acid

The dilute NaClO₂ flows through the ion exchange vessels where the NaClO₂ is converted to HClO₂ through the exchange of the N⁺ in solution for the H⁺ on the cation resin.

Chlorine Dioxide

The HClO₂ is converted to dilute ClO₂ in the catalyst cartridge which produces a low concentration solution (700 mg/L).

Regeneration

The H⁺ ion in the regenerant acid forces the Na⁺ ion off of the exhausted cation resin. The system is a duplex system meaning that one cation vessel is converting NaClO₂ to HClO₂ the other vessel is in regeneration. When the system determines that the first vessel is exhausted, the system automatically switches sides so that HClO₂ production is not interrupted. To increase efficiency, the Impulse Regeneration Method is employed.

Drain

The waste regenerant containing the Na⁺ ions is flushed to drain as part of the regeneration process. The system also primes itself to drain.

ClO₂ IX PORTABLE REGENERATION (PRG)

225g to 9Kg of ClO₂
Model Variants: 2
Potable Design
Regenerable Ion Exchange Vessels
Electric and Water Driven Pump Models
Easy to Manoeuvre

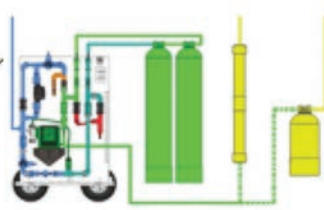

PTG-GRU Electric Pump Series

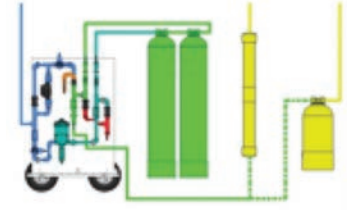

PTG-WTR Water-Driven Pump Series

Inlet Potable Water

A potable water source is required for the system.

Sodium Chlorite

A 25% NaClO₂ solution is diluted with potable water such that the resulting concentration of NaClO₂ is 1,250 mg/L.

Chlorous Acid

The dilute NaClO₂ flows through the ion exchange vessels where the NaClO₂ is converted to HClO₂ through the exchange of the N⁺ in solution for the H⁺ on the cation resin.

Chlorine Dioxide

The HClO₂ is converted to dilute ClO₂ in the catalyst cartridge which produces a low concentration solution (700 mg/l).

Regeneration

The H⁺ ion in the regenerant acid forces the Na⁺ ion off of the exhausted cation resin. The system must be regenerated manually.

Drain

The waste regenerant containing the Na⁺ ions is flushed to drain during the regeneration process.

ClO₂ PORTABLE REGENERATION (PRG)

225g to 9Kg of ClO₂
Model Variants: 2
Potable Design
Replacement Cartridges – no acid on site
Electric and Water Driven Pump Models

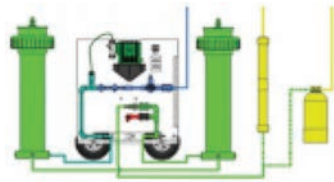

PTG-GRU Electric Pump Series

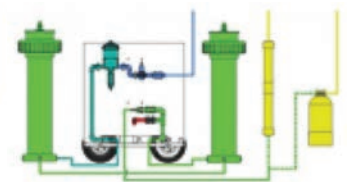

PTG-WTR Water-Driven Pump Series

Inlet Potable Water

A potable water source is required for the system.

Sodium Chlorite

A 25% NaClO₂ solution is diluted with potable water such that the resulting concentration of NaClO₂ is 1,250 mg/L.

Chlorous Acid

The dilute NaClO₂ flows through the ion exchange vessels where the NaClO₂ is converted to HClO₂ through the exchange of the N⁺ in solution for the H⁺ on the cation resin.

Chlorine Dioxide

The HClO₂ is converted to dilute ClO₂ in the catalyst cartridge which produces a low concentration solution (700 mg/l).

Drain

When the catalyst cartridges are changed, water is flushed through the system to drain.

ClO₂X Chlorine Dioxide Generation

	MINI G-015	MINI G-030	MINI G-060	MINI G-120
Catalyst Size				
ClO ₂ Production	15.00	30.00	60.00	120.00
Normal Flow Rate	15.00	30.00	60.00	120.00
Min Flow Rate	15.00	15.00	30.00	60.00
ClO ₂ Solution Production	21.6	43.2	86.4	172
ClO ₂ Concentration	650 - 750		650 - 750	
ClO ₂ Conversion	>75% at 25°C		>75% at 25°C	
Catalyst Dimensions (Dia x H)	0.04 x 0.35		0.04 x 0.35	
Generator Dimensions (W x D x H)	0.76 x 0.76 x 1.88		0.76 x 0.76 x 1.88	
Ion Exchange Tank Dimensions			Ion Exchange Tanks Sold Separately	
Floorspace	0.76 x 0.76		0.76 x 0.76	
Operating Parameters				
Max Feed Water Quality	<1,500		<1,500	
Max Feed Water Conductivity	3,000		3,000	
Ambient Temperature Range	4.4 - 43.0		4.4 - 43.0	
Water Temperature Range	10 to 32		10 to 32	
Remote Access Ports				
Ethernet Communication Port	Yes		Yes	
System can connect to customer provided cell modem or network	Yes		Yes	
Plumbing Connections to Generator				
Inlet Water	3/8" MPT		3/8" MPT	
Product HClO ₂	3/8" FPT		3/8" FPT	
Drain	3/8" FPT		3/8" FPT	
Inlet NaClO ₂	1/4" Tubing		1/4" Tubing	
Inlet Regeneration				
Compressed Air				
Weights (Shipping) Inc packaging	12.5		1.25	
Installation Electrical Requirements				
Compressed Air Requirements	90-240 VAC 2.7A 50/60 Hz		90-240 VAC 2.7A 50/60 Hz	
Air Pressure				
Installation Plumbing Requirements				
Inlet Water Pressure	2.76 - 7.00		2.76 - 7.00	
ΔP Across System	1.72		1.72	
Drain Pressure	Atmospheric		Atmospheric	
Precursor Requirements				
NaClO ₂	7.5% Active		7.5% Active	
Regenerant				
Regenerant H ₂ SO ₄ (optional)				
Precursor Usage				
NaClO ₂ : 7.5%	26 ClO ₂ Produced		26 ClO ₂ Produced	
HCl 31.45%				
HCl 10%				
H ₂ SO ₄ 35% (optional)				
Catalyst Cartridge	Order Separately	Order Separately	Order Separately	Order Separately

* At Nominal Flow Rate

** Catalyst May Need To Be Mounted

Further reading

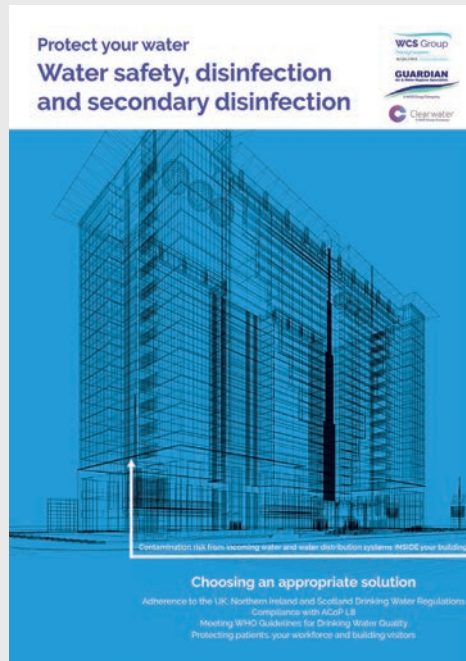

A water safety, secondary disinfection overview is available on the WCS Group website.

Enquiries:
alex.winter@wcs-group.co.uk
or +44 (0)113 200 5214

www.wcs-group.co.uk | www.gwtltd.com | www.clearwater.eu.com



Cert No. 11011
ISO 9001, ISO 14001,
OHSAS 18001

WCS Group is a trading name for WCS Environmental Ltd, registered in England and Wales (Number 02184649) at 20 Grosvenor Place, London, SW1X 7HN.
Head Office – Bristol Road, Cromhall, Gloucestershire, GL12 8AX. The WCS Group is a portfolio company of Marlowe plc. Guardian Water Treatment and Clearwater are both WCS Group companies.