

# DIESEL GENERATOR SET

## MTU 6R0113 DS150

150 kWe / 60 Hz / Standby  
208 - 600V

Reference MTU 6R0113 DS150 (135 kWe) for Prime Rating Technical Data



### SYSTEM RATINGS

#### Standby

Voltage (L-L)	240V**	240V**	208V**	240V**	480V**	600V**
Phase	1	1	3	3	3	3
PF	1	1	0.8	0.8	0.8	0.8
Hz	60	60	60	60	60	60
kW	150	150	150	150	150	150
kVA	150	150	187	187	187	187
Amps	625	625	520	451	226	180
skVA@30%						
Voltage Dip	182	195	296	296	394	315
Generator Model	431CSL6208	431PSL6224	431CSL6202	431CSL6202	431CSL6202	431PSL6240
Temp Rise	130 °C/40 °C	130 °C/40 °C	130 °C/40 °C	130 °C/40 °C	130 °C/40 °C	130 °C/40 °C
Connection	12 LEAD DOUBLE DELTA	4 LEAD	12 LEAD LOW WYE	12 LEAD HI DELTA	12 LEAD HI WYE	4 LEAD WYE

\*\*UL2200 Offered

### CERTIFICATIONS AND STANDARDS

#### // Emissions

- EPA Tier 3 Certified
- South Coast Air Quality Management District (SCAQMD)

// Generator set is designed and manufactured in facilities certified to standards ISO 9001:2008 and ISO 14001:2004

#### // Seismic Certification – Optional

- IBC Certification
- OSHPD Pre-Approval

#### // UL 2200 / CSA – Optional

- UL 2200 Listed
- CSA Certified

#### // Performance Assurance Certification (PAC)

- Generator Set Tested to ISO 8528-5 for Transient Response
- Verified product design, quality and performance integrity
- All engine systems are prototype and factory tested

#### // Power Rating

- Accepts Rated Load in One Step Per NFPA 110

## STANDARD FEATURES\*

- // MTU Onsite Energy is a single source supplier
  - // Global Product Support
  - // 2 Year Standard Warranty
  - // 6068HF285 Diesel Engine
    - 6.8 Liter Displacement
    - 4-Cycle
  - // Engine-generator resilient mounted
  - // Complete Range of Accessories
- // Generator
    - Brushless, Rotating Field Generator
    - 2/3 Pitch Windings
    - 300% Short Circuit Capability with Optional PMG
  - // Digital Control Panel(s)
    - UL Recognized, CSA Certified, NFPA 110
    - Complete System Metering
    - LCD Display
  - // Cooling System
    - Integral Set-Mounted
    - Engine Driven Fan

## STANDARD EQUIPMENT\*

### // Engine

Air Cleaner  
 Oil Pump  
 Oil Drain Extension & S/O Valve  
 Full Flow Oil Filter  
 Fuel Filter with Water Separator  
 Jacket Water Pump  
 Thermostat  
 Blower Fan & Fan Drive  
 Radiator - Unit Mounted  
 Electric Starting Motor - 12V  
 Governor - Electronic Isochronous  
 Base - Formed Steel  
 SAE Flywheel & Bell Housing  
 Charging Alternator - 12V  
 Battery Box & Cables  
 Flexible Fuel Connectors  
 Flexible Exhaust Connection  
 EPA Certified Engine

### // Generator

NEMA MG1, IEEE and ANSI standards compliance for temperature rise and motor starting  
 Self-Ventilated and Drip-Proof  
 Superior Voltage Waveform  
 Solid State, Volts-per-Hertz Regulator  
 ±1% Voltage Regulation No Load to Full Load  
 Brushless Alternator with Brushless Pilot Exciter  
 4 Pole, Rotating Field

130 °C Maximum Standby Temperature Rise  
 1 Bearing, Sealed  
 Flexible Coupling  
 Full Amortisseur Windings  
 125% Rotor Balancing  
 3-Phase Voltage Sensing  
 100% of Rated Load - One Step  
 5% Maximum Total Harmonic Distortion

### // Digital Control Panel(s)

Digital Metering  
 Engine Parameters  
 Generator Protection Functions  
 Engine Protection  
 SAE J1939 Engine ECU Communications  
 Windows®-Based Software  
 Multilingual Capability  
 Remote Communications to RDP-110 Remote Annunciator  
 Programmable Input and Output Contacts  
 UL Recognized, CSA Certified, CE Approved  
 Event Recording  
 IP 54 Front Panel Rating with Integrated Gasket  
 NFPA110 Compatible

\* Represents standard product only. Consult Factory/MTU Onsite Energy Distributor for additional configurations.

## APPLICATION DATA

### // Engine

Manufacturer	John Deere
Model	6068HF285
Type	4-Cycle
Arrangement	6-Inline
Displacement: L (in <sup>3</sup> )	6.8 (415)
Bore: cm (in)	10.6 (4.19)
Stroke: cm (in)	12.7 (5)
Compression Ratio	19:1
Rated RPM	1,800
Engine Governor	JDEC
Maximum Power: kWm (bhp)	177 (237)
Speed Regulation	±0.25%
Air Cleaner	Dry

### // Liquid Capacity (Lubrication)

Total Oil System: L (gal)	20 (5.28)
Engine Jacket Water Capacity: L (gal)	12.3 (3.25)
System Coolant Capacity: L (gal)	22.7 (6)

### // Electrical

Electric Volts DC	12
Cold Cranking Amps Under -17.8 °C (0 °F)	925

### // Fuel System

Fuel Supply Connection Size	3/8" NPT
Fuel Return Connection Size	3/8" NPT
Maximum Fuel Lift: m (ft)	2 (6.7)
Recommended Fuel	Diesel #2
Total Fuel Flow: L/hr (gal/hr)	107.2 (28.3)

### // Fuel Consumption

At 100% of Power Rating: L/hr (gal/hr)	44.7 (11.8)
At 75% of Power Rating: L/hr (gal/hr)	34.8 (9.2)
At 50% of Power Rating: L/hr (gal/hr)	25.4 (6.7)

### // Cooling - Radiator System

Ambient Capacity of Radiator: °C (°F)	50 (122)
Maximum Allowable Static Pressure on Rad. Exhaust: kPa (in. H <sub>2</sub> O)	0.12 (0.5)
Water Pump Capacity: L/min (gpm)	180 (48)
Heat Rejection to Coolant: kW (BTUM)	93.5 (5,324)
Heat Rejection to Air to Air: kW (BTUM)	32 (1,821)
Heat Radiated to Ambient: kW (BTUM)	25.7 (1,461)
Fan Power: kW (hp)	10.7 (14.3)

### // Air Requirements

Aspirating: *m <sup>3</sup> /min (SCFM)	13.6 (480)
Air Flow Required for Rad. Cooled Unit: *m <sup>3</sup> /min (SCFM)	304 (10,732)
Remote Cooled Applications; Air Flow Required for Dissipation of Radiated Gen-set Heat for a Max of 25 °F Rise: *m <sup>3</sup> /min (SCFM)	94 (3,295)

\* Air density = 1.184 kg/m<sup>3</sup> (0.0739 lbm/ft<sup>3</sup>)

### // Exhaust System

Gas Temp. (Stack): °C (°F)	505 (941)
Gas Volume at Stack Temp: m <sup>3</sup> /min (CFM)	34 (1,201)
Maximum Allowable Back Pressure: kPa (in. H <sub>2</sub> O)	7.5 (30)

## WEIGHTS AND DIMENSIONS

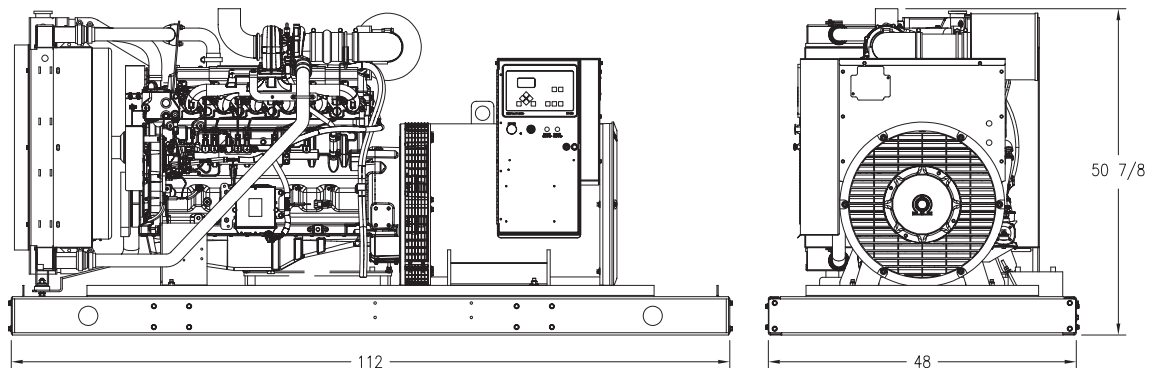

Drawing above for illustration purposes only, based on standard open power 480 volt generator set. Lengths may vary with other voltages. Do not use for installation design. See website for unit specific template drawings.

### System

Open Power Unit (OPU)

### Dimensions (L x W x H)

2,845 x 1,219 x 1,283 mm (112 x 48 x 50.5 in)

### Weight (less tank)

1,573-2,262 kg (3,469-4,986 lb)

Weights and dimensions are based on open power units and are estimates only. Consult the factory for accurate weights and dimensions for your specific generator set.

## SOUND DATA

### Unit Type

Level 0: Open Power Unit dB(A)

### Standby Full Load

85.1

Sound data is provided at 7 m (23 ft). Generator set tested in accordance with ISO 8528-10 and with infinite exhaust.

## EMISSIONS DATA

### NO<sub>x</sub> + NMHC

3.77

### CO

0.4

### PM

0.06

**All units are in g/hp-hr and shown at 100% load (not comparable to EPA weighted cycle values).**

Emission levels of the engine may vary with ambient temperature, barometric pressure, humidity, fuel type and quality, installation parameters, measuring instrumentation, etc. The data was obtained in compliance with US EPA regulations. The weighted cycle value (not shown) from each engine is guaranteed to be within the US EPA Standards. 5-mode emission data per 40 CFR 89 or 40 CFR 1039 (as applicable) is available upon request.

## RATING DEFINITIONS AND CONDITIONS

// Standby ratings apply to installations served by a reliable utility source. The standby rating is applicable to varying loads for the duration of a power outage. No overload capability for this rating. Ratings are in accordance with ISO 3046-1, BS 5514, and AS 2789. Average load factor: ≤ 85%.

// Deration Factor:

**Altitude:** Consult your local MTU Onsite Energy Power Generation Distributor for altitude derations.

**Temperature:** Consult your local MTU Onsite Energy Power Generation Distributor for temperature derations.

C/F = Consult Factory/MTU Onsite Energy Distributor

N/A = Not Available

**MTU Onsite Energy**

A Rolls-Royce Power Systems Brand

[www.mtuonsiteenergy.com](http://www.mtuonsiteenergy.com)