

DIESEL GENERATOR SET

MTU 6R0113 DS180

180 kWe / 60 Hz / Prime
208 - 600V

Reference MTU 6R0113 DS180 (180 kWe) for Standby Rating Technical Data



SYSTEM RATINGS

Prime

Voltage (L-L)	240V**	240V**	208V**	240V**	480V**	600V**
Phase	C/F	C/F	3	3	3	3
PF	C/F	C/F	0.8	0.8	0.8	0.8
Hz	C/F	C/F	60	60	60	60
kW	C/F	C/F	180	180	180	180
kVA	C/F	C/F	225	225	225	225
Amps	C/F	C/F	625	541	271	217
skVA@30%						
Voltage Dip	C/F	C/F	454	454	577	510
Generator Model	C/F	C/F	431CSL6208	431CSL6208	431CSL6206	431PSL6243
Temp Rise	C/F	C/F	105 °C/40 °C	105 °C/40 °C	105 °C/40 °C	105 °C/40 °C
Connection	C/F	C/F	12 LEAD LOW WYE	12 LEAD HI DELTA	12 LEAD HI WYE	4 LEAD WYE

** UL 2200 Offered

CERTIFICATIONS AND STANDARDS

// Emissions

- EPA Tier 3 Certified
- South Coast Air Quality Management District (SCAQMD)

// Generator set is designed and manufactured in facilities certified to standards ISO 9001:2008 and ISO 14001:2004

// Seismic Certification – Optional

- IBC Certification
- OSHPD Pre-Approval

// UL 2200 / CSA – Optional

- UL 2200 Listed
- CSA Certified

// Performance Assurance Certification (PAC)

- Generator Set Tested to ISO 8528-5 for Transient Response
- Verified product design, quality and performance integrity
- All engine systems are prototype and factory tested

// Power Rating

- Accepts Rated Load in One Step Per NFPA 110

STANDARD FEATURES*

- // MTU Onsite Energy is a single source supplier
 - // Global Product Support
 - // 2 Year Standard Warranty
 - // 6068HFG85 Diesel Engine
 - 6.8 Liter Displacement
 - 4-Cycle
 - // Engine-generator resilient mounted
 - // Complete Range of Accessories
- // Generator
 - Brushless, Rotating Field Generator
 - 2/3 Pitch Windings
 - 300% Short Circuit Capability with Optional PMG
 - // Digital Control Panel(s)
 - UL Recognized, CSA Certified, NFPA 110
 - Complete System Metering
 - LCD Display
 - // Cooling System
 - Integral Set-Mounted
 - Engine Driven Fan

STANDARD EQUIPMENT*

// Engine

Air Cleaners
 Oil Pump
 Oil Drain Extension & S/O Valve
 Full Flow Oil Filter
 Fuel Filter with Water Separator
 Jacket Water Pump
 Thermostat
 Blower Fan & Fan Drive
 Radiator - Unit Mounted
 Electric Starting Motor - 12V
 Governor - Electronic Isochronous
 Base - Formed Steel
 SAE Flywheel & Bell Housing
 Charging Alternator - 12V
 Battery Box & Cables
 Flexible Fuel Connectors
 Flexible Exhaust Connection
 EPA Certified Engine

// Generator

NEMA MG1, IEEE and ANSI standards compliance for temperature rise and motor starting
 Self-Ventilated and Drip-Proof
 Superior Voltage Waveform
 Solid State, Volts-per-Hertz Regulator
 $\pm 1\%$ Voltage Regulation No Load to Full Load
 Brushless Alternator with Brushless Pilot Exciter
 4 Pole, Rotating Field

105 °C Maximum Prime Temperature Rise
 1 Bearing, Sealed
 Flexible Coupling
 Full Amortisseur Windings
 125% Rotor Balancing
 3-Phase Voltage Sensing
 100% of Rated Load - One Step
 5% Maximum Total Harmonic Distortion

// Digital Control Panel(s)

Digital Metering
 Engine Parameters
 Generator Protection Functions
 Engine Protection
 SAE J1939 Engine ECU Communications
 Windows®-Based Software
 Multilingual Capability
 Remote Communications to RDP-110 Remote Annunciator
 Programmable Input and Output Contacts
 UL Recognized, CSA Certified, CE Approved
 Event Recording
 IP 54 Front Panel Rating with Integrated Gasket
 NFPA 110 Compatible

* Represents standard product only. Consult Factory/MTU Onsite Energy Distributor for additional configurations.

APPLICATION DATA

// Engine

Manufacturer	John Deere
Model	6068HFG85
Type	4-Cycle
Arrangement	6-Inline
Displacement: L (in ³)	6.8 (415)
Bore: cm (in)	10.6 (4.2)
Stroke: cm (in)	12.7 (5)
Compression Ratio	17:1
Rated RPM	1,800
Engine Governor	JDEC
Maximum Power: kWm (bhp)	214 (286)
Speed Regulation	±0.25%
Air Cleaner	Dry

// Liquid Capacity (Lubrication)

Total Oil System: L (gal)	32.2 (8.5)
Engine Jacket Water Capacity: L (gal)	11.9 (3.3)
System Coolant Capacity: L (gal)	29.3 (7.75)

// Electrical

Electric Volts DC	12
Cold Cranking Amps Under -17.8 °C (0 °F)	925

// Fuel System

Fuel Supply Connection Size	3/8" NPT
Fuel Return Connection Size	3/8" NPT
Maximum Fuel Lift: m (ft)	2 (6.7)
Recommended Fuel	Diesel #2
Total Fuel Flow: L/hr (gal/hr)	93 (24.5)

// Fuel Consumption

At 100% of Power Rating: L/hr (gal/hr)	51.9 (13.5)
At 75% of Power Rating: L/hr (gal/hr)	40.5 (10.7)
At 50% of Power Rating: L/hr (gal/hr)	27.6 (7.3)

// Cooling - Radiator System

Ambient Capacity of Radiator: °C (°F)	50 (122)
Maximum Restriction of Cooling Air, Intake, and Discharge Side of Rad.: kPa (in. H ₂ O)	0.12 (0.5)
Water Pump Capacity: L/min (gpm)	265 (70)
Heat Rejection to Coolant: kW (BTUM)	83.7 (4,766)
Heat Rejection to Air to Air: kW (BTUM)	40 (2,298)
Heat Radiated to Ambient: kW (BTUM)	25.5 (1,453)
Fan Power: kW (hp)	8.6 (11.5)

// Air Requirements

Aspirating: *m ³ /min (SCFM)	14.7 (520)
Air Flow Required for Rad.	
Cooled Unit: *m ³ /min (SCFM)	412 (14,537)
Remote Cooled Applications; Air Flow Required for Dissipation of Radiated Gen-set Heat for a Max of 25 °F Rise: *m ³ /min (SCFM)	93 (3,277)

* Air density = 1.184 kg/m³ (0.0739 lbm/ft³)

// Exhaust System

Gas Temp. (Stack): °C (°F)	528 (982)
Gas Volume at Stack Temp: m ³ /min (CFM)	38.8 (1,371)
Maximum Allowable Back Pressure: kPa (in. H ₂ O)	10 (40)

WEIGHTS AND DIMENSIONS

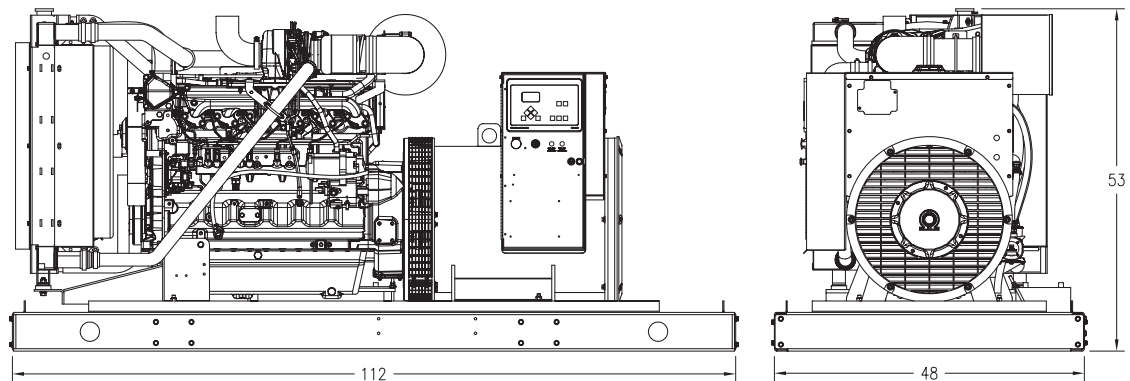

Drawing above for illustration purposes only, based on standard open power 480 volt generator set. Lengths may vary with other voltages. Do not use for installation design. See website for unit specific template drawings.

System

Open Power Unit (OPU)

Dimensions (L x W x H)

2,845 x 1,219 x 1,346 mm (112 x 48 x 53 in)

Weight (less tank)

1,573-2,262 kg (3,469-4,986 lb)

Weights and dimensions are based on open power units and are estimates only. Consult the factory for accurate weights and dimensions for your specific generator set.

SOUND DATA

Unit Type

Level 0: Open Power Unit dB(A)

Prime Full Load

87.2

Sound data is provided at 7 m (23 ft). Generator set tested in accordance with ISO 8528-10 and with infinite exhaust.

EMISSIONS DATA

NO_x + NMHC

4.63

CO

0.49

PM

0.09

All units are in g/hp-hr and shown at 100% load (not comparable to EPA weighted cycle values).

Emission levels of the engine may vary with ambient temperature, barometric pressure, humidity, fuel type and quality, installation parameters, measuring instrumentation, etc. The data was obtained in compliance with US EPA regulations. The weighted cycle value (not shown) from each engine is guaranteed to be within the US EPA Standards. 5-mode emission data per 40 CFR 89 or 40 CFR 1039 (as applicable) is available upon request.

RATING DEFINITIONS AND CONDITIONS

// Prime power ratings apply to installations where utility power is unavailable or unreliable. At varying load, the number of generator set operating hours is unlimited. A 10% overload capacity is available for one hour in twelve. Ratings are in accordance with ISO 8528-1, overload power in accordance with ISO 3046-1, BS 5514, and AS 2789. Average load factor: ≤ 75%.

// Deration Factor:

Altitude: Consult your local MTU Onsite Energy Power Generation Distributor for altitude derations.

Temperature: Consult your local MTU Onsite Energy Power Generation Distributor for temperature derations.

C/F = Consult Factory/MTU Onsite Energy Distributor

N/A = Not Available

MTU Onsite Energy

A Rolls-Royce Power Systems Brand

www.mtuonsiteenergy.com