

GAS GENERATOR SET

MTU 10V0068 GS75

75 kWe / 60 Hz / Standby
208 - 600V



SYSTEM RATINGS

Standby

Voltage (L-L)	240V**	240V**	208V**	240V**	480V**	600V**
Phase	1	1	3	3	3	3
PF	1	1	0.8	0.8	0.8	0.8
Hz	60	60	60	60	60	60
Natural Gas (NG)						
Amps	292	292	243	210	105	84
kW/kVA	70/70	70/70	70/87.5	70/87.5	70/87.5	70/87.5
Liquid Propane (LP)						
Amps	313	313	260	226	113	90
kW/kVA	75/75	75/75	75/93.75	75/93.75	75/93.75	75/93.75
NG and LP						
skVA@30%						
Voltage Dip	311	107	216	216	288	235
Generator Model	363CSL1617	431CSL6202	362CSL1604	362CSL1604	362CSL1604	362PSL1635
Temp Rise	130 °C/40 °C	130 °C/40 °C	130 °C/40 °C	130 °C/40 °C	130 °C/40 °C	130 °C/40 °C
Connection	4 LEAD	12 LEAD DOUBLE DELTA	12 LEAD LOW WYE	12 LEAD HI DELTA	12 LEAD HI WYE	4 LEAD WYE

**UL2200 Offered

Note: This unit is available with a dual fuel configuration.

CERTIFICATIONS AND STANDARDS

// **Generator set is designed and manufactured in facilities certified to standards ISO 9001:2008 and ISO 14001:2004**

// **Seismic Certification – Optional**

- IBC Certification
- OSHPD Pre-Approval

// **UL 2200 / CSA – Optional**

- UL 2200 Listed
- CSA Certified

// **Performance Assurance Certification (PAC)**

- Generator Set Tested to ISO 8528-5 for Transient Response
- Verified product design, quality and performance integrity
- All engine systems are prototype and factory tested

// **Power Rating**

- Accepts Rated Load in One Step Per NFPA 110

STANDARD FEATURES*

- // MTU Onsite Energy is a single source supplier
 - // Global Product Support
 - // 2 Year Standard Warranty
 - // 6.8L Engine
 - 6.8 Liter Displacement
 - 4-Cycle
 - // Optional Fuels: LP Liquid and Dual Fuel
 - // Engine-generator resilient mounted
 - // Complete Range of Accessories
- // Generator
 - Brushless, Rotating Field Generator
 - 2/3 Pitch Windings
 - 300% Short Circuit Capability with Optional Permanent Magnet Generator (PMG)
 - // Digital Control Panel(s)
 - UL Recognized, CSA Certified, NFPA 110
 - Complete System Metering
 - LCD Display
 - // Cooling System
 - Integral Set-Mounted
 - Engine-Driven Fan

STANDARD EQUIPMENT*

// Engine

Heavy Duty Air Cleaner
 Oil Pump
 Oil Drain Extension and S/O Valve
 Full Flow Oil Filter
 Jacket Water Pump
 Thermostat
 Blower Fan and Fan Drive
 Radiator - Unit Mounted
 Electric Starting Motor - 12V
 Governor - Electronic Isochronous
 Base - Formed Steel
 SAE Flywheel and Bell Housing
 Charging Alternator - 12V
 Battery Rack and Cables
 Flexible Exhaust Connection
 EPA Certified Engine

// Generator

NEMA MG 1, IEEE and ANSI standards compliance for temperature rise and motor starting
 Sustained short circuit current of up to 300% of the rated current for up to 10 seconds
 Self-Ventilated
 Superior Voltage Waveform
 Solid State, Volts-per-Hertz Regulator
 ±1% Voltage Regulation No Load to Full Load Regulation

Brushless Alternator with Brushless Pilot Exciter
 4 Pole, Rotating Field
 130 °C Max. Standby Temperature Rise
 1 Bearing, Sealed
 Flexible Coupling
 Full Amortisseur Windings
 125% Rotor Balancing
 3-Phase Voltage Sensing
 100% of Rated Load - One Step
 5% Max. Total Harmonic Distortion

// Digital Control Panel(s)

Digital Metering
 Engine Parameters
 Generator Protection Functions
 Engine Protection
 SAE J1939 Engine ECU Communications
 Windows®-Based Software
 Multilingual Capability
 Remote Communications to RDP-110 Remote Annunciator
 Programmable Input and Output Contacts
 UL Recognized, CSA Certified, CE Approved
 Event Recording
 IP 54 Front Panel Rating with Integrated Gasket
 NFPA 110 Compatible

* Represents standard product only. Consult Factory/MTU Onsite Energy Distributor for additional configurations.

APPLICATION DATA

// Engine

Manufacturer	MTU
Model	6.8L V10
Type	4-Cycle
Aspiration	Naturally Aspirated
Arrangement	10-V
Displacement: L (in ³)	6.8 (415)
Bore: cm (in)	9 (3.55)
Stroke: cm (in)	10.6 (4.17)
Compression Ratio	9:1
Rated RPM	1,800
Engine Governor	Bosch
Max. Power (NG): kWm (bhp)	85.6 (114.8)
Max. Power (LP): kWm (bhp)	89.4 (119.9)
Speed Regulation	C/F
Air Cleaner	Dry

// Liquid Capacity (Lubrication)

Total Oil System: L (gal)	5.7 (1.5)
Engine Jacket Water Capacity: L (gal)	5.9 (1.55)
System Coolant Capacity: L (gal)	25.58 (6.75)

// Electrical

Electric Volts DC	12
Cold Cranking Amps Under -17.8 °C (0 °F)	925

// Fuel Inlet - Vaporous Supply

Fuel Supply Connection Size	1 1/2" NPT
Fuel Supply Pressure: mm H ₂ O (in. H ₂ O)	178-279 (7-11)

// Fuel Inlet - Liquid Supply

Fuel Supply Connection Size	#6 (3/8") Female SAE 45° Flare
Max. Fuel Supply Pressure: kPa (PSI)	2,150 (312)

// Fuel Consumption (NG-1000 BTU/ft³ / LP-2500 BTU/ft³)

	NG	LPG
At 100% of Power Rating: m ³ /hr (ft ³ /hr)	27.2 (960)	11.4 (403)
At 75% of Power Rating: m ³ /hr (ft ³ /hr)	21.5 (759)	9.3 (328)
At 50% of Power Rating: m ³ /hr (ft ³ /hr)	15.6 (551)	6.8 (239)

// Cooling - Radiator System

	NG and LPG
Ambient Capacity of Radiator: °C (°F)	50 (122)
Max. Restriction of Cooling Air: Intake and Discharge Side of Rad.: kPa (in. H ₂ O)	0.12 (0.5)
Water Pump Capacity: L/min (gpm)	123 (32.5)
Heat Rejection to Coolant: kW (BTUM)	78.2 (4,448)
Heat Radiated to Ambient: kW (BTUM)	19.1 (1,086)
Fan Power: kW (hp)	2.8 (3.8)

// Air Requirements

	NG and LPG
Aspirating: *m ³ /min (SCFM)	4.54 (160.5)
Air Flow Required for Rad. Cooled Unit: *m ³ /min (SCFM)	303.4 (10,715)
Remote Cooled Applications; Air Flow Required for Dissipation of Radiated Generator Set Heat For a Max. of 25 °F Rise: *m ³ /min (SCFM)	103 (3,369)

* Air density = 1.184 kg/m³ (0.0739 lbm/ft³)

// Exhaust System

	NG and LPG
Gas Temp. (Stack): °C (°F)	660 (1,220)
Gas Volume at Stack	
Temp: m ³ /min (CFM)	15.3 (539)
Max. Allowable Back Pressure: kPa (in. H ₂ O)	4.98 (20)

WEIGHTS AND DIMENSIONS

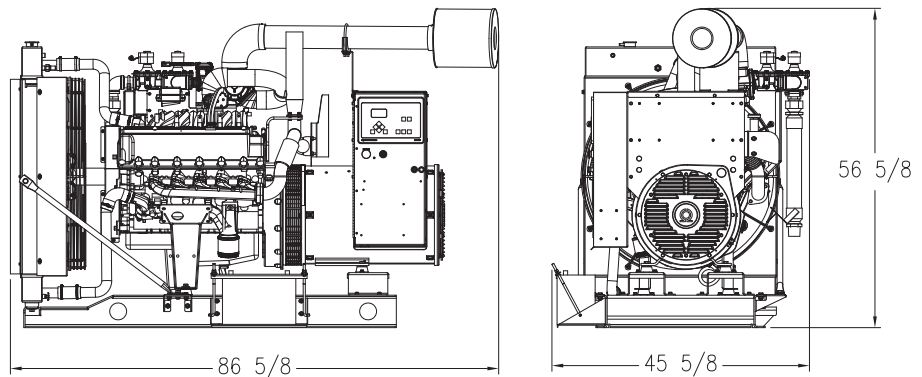

Drawing above for illustration purposes only, based on standard open power 480 volt generator set. Lengths may vary with other voltages. Do not use for installation design. See website for unit specific template drawings.

System

Open Power Unit (OPU)

Dimensions (LxWxH)

2,199 x 1,158 x 1,438 mm (86.6 x 45.6 x 56.6 in)

Weight (dry)

1,012-1,602 kg (2,231-3,531 lb)

Weights and dimensions are based on open power units and are estimates only. Consult the factory for accurate weights and dimensions for your specific generator set.

SOUND DATA

Unit Type

Level 0: Open Power Unit dB(A)

Standby Full Load (NG)

75.5

Standby Full Load (LP)

76.1

Sound data is provided at 7 m (23 ft). Generator set tested in accordance with ISO 8528-10 and with infinite exhaust.

EMISSIONS DATA

Fuel Type	THC + NO _x	CO
Natural Gas	7.53	30.49
Liquid Propane	7.65	47.95

All units are in g/hp-hr and are EPA weighted cycle values.

Emission levels of the engine may vary with ambient temperature, barometric pressure, humidity, fuel type and quality, installation parameters, measuring instrumentation, etc. The data was obtained in compliance with US EPA regulations.

RATING DEFINITIONS AND CONDITIONS

// Standby ratings apply to installations served by a reliable utility source. The standby rating is applicable to varying loads for the duration of a power outage. No overload capability for this rating. Ratings are in accordance with ISO 3046-1, BS 5514, and AS 2789. Average load factor: ≤ 85%.

// Deration Factor:

Altitude: Consult your local MTU Onsite Energy Power Generation Distributor for altitude derations.

Temperature: Consult your local MTU Onsite Energy Power Generation Distributor for temperature derations.

C/F = Consult Factory/MTU Onsite Energy Distributor

N/A = Not Available

MTU Onsite Energy

A Rolls-Royce Power Systems Brand

www.mtuonsiteenergy.com