

# AUTOMATIC CONTROL SYSTEMS FOR SUCCESSFUL CHP INSTALLATIONS



By **Christian Mueller**  
 Manager Sales Engineering  
 Gas Power Systems  
 MTU Onsite Energy

Modern CHP installations require a wide range of equipment, seamlessly integrated with the facility's heating, ventilation and air conditioning (HVAC) system, electrical systems and utility interconnections. Keeping everything operating safely and optimally is no small task, but thanks to advancements in automatic control systems, it's never been easier.

## Why do CHP installations require automatic control systems?

There's more to operating a successful cogeneration plant than installing a properly specified CHP generator set and turning it on. To ensure safe and reliable operation, every piece of equipment needs to work together seamlessly—from the generator set and mechanical "balance of plant" systems (e.g. pumps, valves, radiators and heat exchangers) to the facility's HVAC system, electrical systems and utility interconnections. Vital equipment data and operating parameters such as pressure, temperature and filling levels need to be continuously monitored and transmitted throughout the system—and made easily accessible and understandable to the plant's operators. Automatic controls provide the brains to make all of this possible.

## What are the core functions of an automatic control system?

Automatic controls manage the activity of one or more sub-systems, including:

- // Engine operation
- // Generator operation
- // Paralleling and synchronizing
- // Remote access / software interfaces
- // Balance of plant operation
- // Human Machine Interface (HMI)

Most CHP generator sets come equipped with controls to manage engine and generator performance. Mounted directly on the base frame of all MTU Onsite Energy CHP systems, the MTU Interface Panel (MIP) manages engine and generator operation. It also controls paralleling and synchronizing with other sources of electricity, such as the utility or other generator sets, and provides remote access and software interfacing capabilities.

To control the rest of the cogeneration plant, including balance of plant equipment and various human machine interfaces (HMI), additional controls are needed. These controls are typically installed in a separate location, such as a control room, where engine heat and noise can be minimized. They often include a touchscreen interface for the operator and various inputs and outputs (I/O's) to interconnect with other equipment, such as the facility's thermal and electrical systems. MTU Onsite Energy's highly customizable solution—the MTU Module Control (MMC)—seamlessly links with the MIP engine and generator set controls by cable, making all vital data and functions accessible to the operator from one convenient location.

The optimal control system for a CHP project depends on several important factors:

- // Engine/generator specifications and availability of pre-installed controls
- // Planned modes of operation
- // System and plant control requirements
- // Remote access interface requirements

The purpose of this paper is to consider each of these factors in detail, starting with engine and generator controls.

## ENGINE AND GENERATOR CONTROLS

There's a direct correlation between advancements in engine technology and the use of electronic controls, and modern CHP systems are no exception. Without adequate controls it would be nearly impossible to monitor the facility's fluctuating thermal and electrical demands, calculate the engine speed and torque needed to meet those demands, and manage subsequent equipment operation in order to safely and reliably deliver the required heat and electricity.

The controls that make all of this possible are generally built around the engine, the generator and accessories. Manufacturers specializing in complete systems will often integrate these controls into a single interface, such as the MTU Interface Panel (MIP), which comes pre-wired and factory-tested on every MTU Onsite Energy CHP unit.

The MIP consolidates the following controls and functions:

### Generator Set Controls

- // Starter Battery Charger
- // Gas train control
- // Engine oil system (refilling)
- // I/O's (Inputs/Outputs), auxiliary drives
- // Parallel/Island operation
- // Load sharing
- // PLC (Programmable Logic Controller)
- // AVR (Automatic Voltage Regulator)
- // Energy-Measure-Module - controls synchronization (GCB/MCB), generator protection, mains protection/monitoring

### Engine Control Unit (ECU)

- // Gas supply (mixture/lambda)
- // Throttle / speed control
- // Ignition control
- // Turbo bypass
- // Knocking detection / control
- // Engine sensors / monitoring
- // Emission sensor (NOx)
- // Start / stop procedure

### Accessory Controls

- // Alarm system
- // Data logging
- // Visualization (webservice)
- // MMC/MCS interfaces (Ethernet)
- // Customer interfaces (ex. Modbus)
- // HMI touchscreen
- // Remote monitoring and diagnostic

### How it works: Engine mechanics

Reciprocating engines, such as those used in an MTU Onsite Energy CHP system, generate power by combusting a mixture of air and fuel (gas). The process starts with the air/fuel mixture passing through a turbocharger to boost its pressure. Increasing the pressure helps improve combustion, resulting in greater efficiency and power, but it also makes the mixture very hot. After passing through an intercooler, a sensor measures the pressure of the mixture and, if necessary, relieves excess pressure by rerouting a portion of the mixture back in front of the turbocharger via a bypass. The remaining pressure- and temperature-

optimized mixture is distributed through two throttle valves (ProAct A and B) to the individual cylinder banks for combustion.

### How it works: Engine and generator controls

The amount of air/gas mixture supplied to the engine regulates how fast the engine will run, and how much power it will generate. On an MTU Onsite Energy CHP generator set the Programmable Logic Controller (PLC) sets a target speed for the engine based on the thermal and electrical demands of the facility. The target speed may be above or below the engine's actual running speed. In these cases a signal is sent to the speed controls, which then adjust the speed of the engine by changing the gas supply. Two systems work together to determine the ideal gas supply—one considers the amount of fuel in the air/fuel mixture (ratio) while the other considers the total quantity (volume) of the mixture.

The ideal mixture ratio and volume are calculated based on assumptions about the quality of the fuel. In reality, the quality of gaseous fuels fluctuates—especially biogas. Control systems account for these fluctuations by sensing variations and telling the engine how to respond to them. For example, if a change in gas supply does not result in the expected engine speed, the controls will automatically calculate the delta (deviation factor) between what was expected and what actually happened, and keep the system running by adjusting its parameters accordingly.

## ENGINE AND GENERATOR CONTROLS

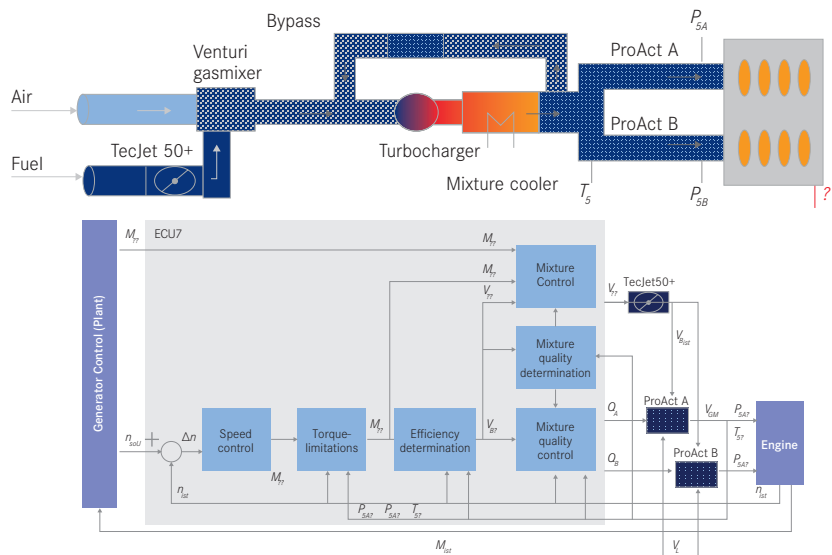

## MODES OF OPERATION

While every CHP installation is unique, it's easy to classify most installations simply by considering the mode of operation: Mains Parallel, Mains Backup or Island. In all cases, engine and generator set controls play a crucial role in operating the equipment safely and reliably.

### Mains Parallel Operation

In most installations, the CHP provides only a portion of the total electricity consumed by a facility. The CHP system is therefore paralleled with the electric utility. In these instances, it is necessary to synchronize the frequency, voltage and phasing of the CHP-supplied electricity with that of the utility. Synchronization is regulated by the engine and generator set controls, which automatically close the generator circuit breaker to the utility source once the generator set is running in parallel with the utility. Once the breaker is closed, the CHP essentially becomes a grid-connected power plant with total power output (kW) and power factor (PF) regulated based on the demands of the facility.

Running in parallel with the utility requires an interconnection agreement, which involves satisfying many of the same safety requirements as other power plants connected to the grid. The engine and generator set controls play a vital role in this regard. To protect the mains and the generator, the voltages and frequencies of both systems must be continuously monitored. If the grid becomes unstable and triggers over/under trip criteria, in cases such as a blackout, the breaker will automatically be reopened and the CHP will be disconnected.

Within the MTU Onsite Energy MIP, all synchronization, protection and automatic disconnection activities are controlled by the Energy Measuring Module (EMM). The mains protection functions of the EMM include monitoring the mains frequency and voltage (high and low), asymmetry and phase shift. Similarly, the generator protection functions include monitoring the generator sets frequency and voltage (high and low), overload and reverse power, overcurrent (level 1 and 2) and unbalanced load.

## MIP CONTROLS

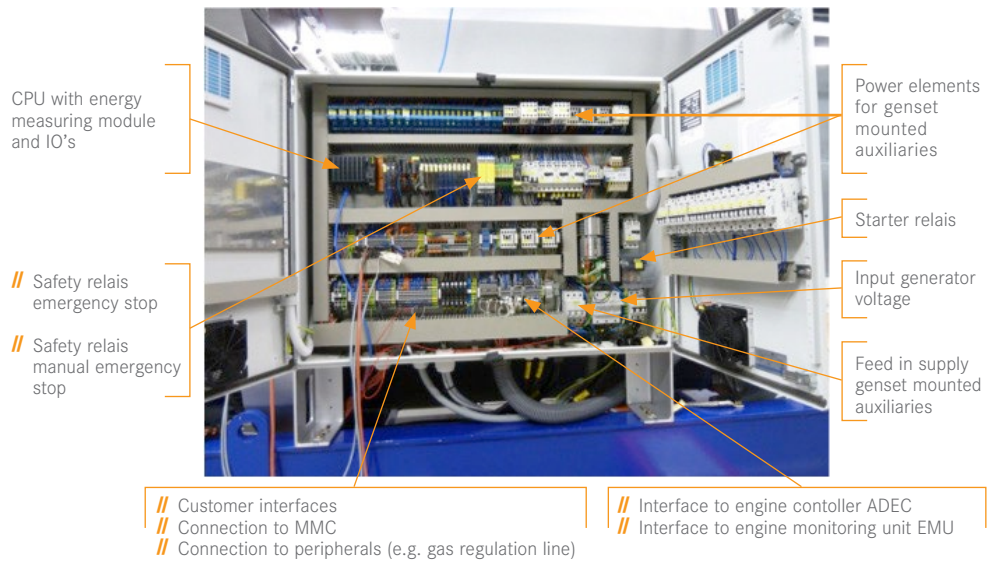

The MTU Interface Panel (MIP) is designed to interface with the MTU Module Controls (MMP) system controls or function as a standalone unit that communicates with a third party control unit via Ethernet-UDP connection.

Controls like the MIP provide several operating modes, which can be set to run independently or prioritized and run in combination. These modes include:

- // Power setpoint - Operates generator set based on target load/electricity production (between 0-100%) variable value (between 4-20mA)
- // Fixed value - Operates generator set based on target load/electricity production (up to 100%) fixed value
- // Power export control - Monitors facility electricity consumption and automatically ramps generator set up or down based on facility demands (e.g. to prevent from exporting power to utility)
- // Heating mode - Monitors facility heat consumption (e.g. return temperature of heating water) and automatically ramps generator set up or down to meet facility demands
- // Buffer storage mode - Monitors facility heat consumption (e.g. temperature of hot water tank) and automatically ramps generator set up or down to meet facility demands
- // Biogas tank - Monitors biogas pressure and automatically ramps generator set up or down gradually based on fuel availability

### Mains Backup Operation

Normally, a generator set is connected to run in mains parallel operation with the utility, but it's also possible to provide backup power in the event of a mains failure. Similar to mains parallel operation, if a utility failure results in a power loss the generator set will automatically disconnect from the mains. However, in mains backup operation the operator can restore power to the facility using the generator set. In mains backup mode, without the utility to regulate frequency and voltage (e.g. 60Hz and 480V) the engine governor and AVR assume this responsibility.

In mains backup operation, the generator set is the only power source. The connected loads determine power demands (active and reactive). As more users are connected, more power is needed and more load is placed on the generator set. Without the option to import power from the utility, the operator must be careful not to overload the generator set, which cannot exceed its specified output. If the generator set is overloaded, it will trip and must then be restarted. Once utility power is restored, the generator set will synchronize to the utility and return to mains parallel operation.

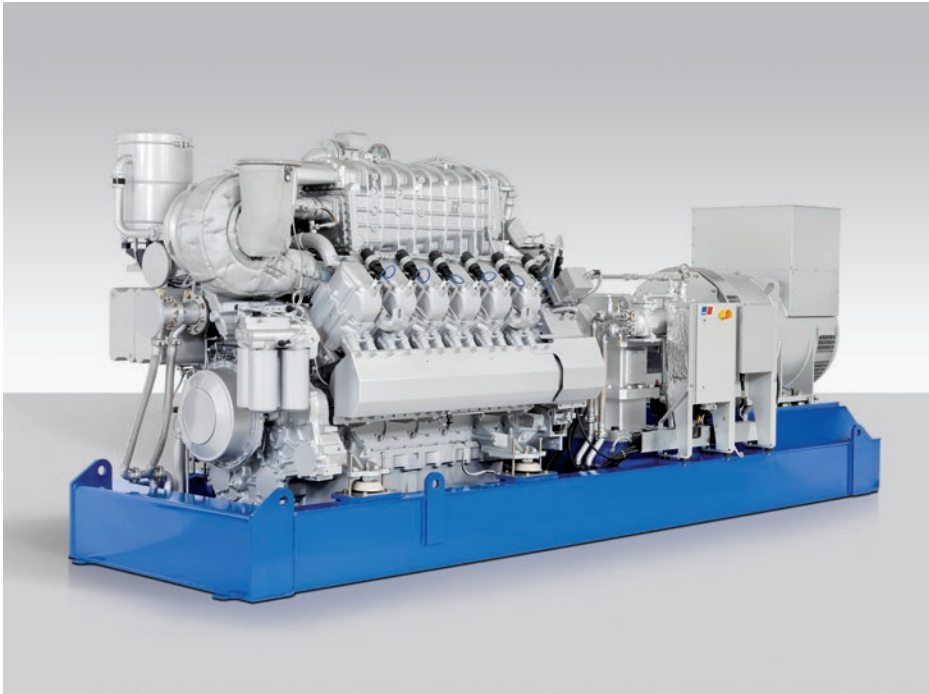

Natural gas-fueled CHP systems achieve total efficiencies exceeding 90 percent.

As with mains parallel operation, the MIP provides several operating modes for mains backup operation:

- // Mode 1 - No interruption at grid failure, interruption at grid return
- // Mode 2 - No interruption at grid failure, no interruption at grid return
- // Mode 3 - Interruption at grid failure, interruption at grid return
- // Mode 4 - Interruption at grid failure, no interruption at grid return (preferred mode for most installations)

In order to prevent a load change (interruption) at grid failure, modes 1 and 2 require zero load control. In other words, the generator set must be capable of carrying the load of the entire facility on its own. This is less common because most CHP installations are built to offset only a portion of the total load in order to maximize runtime and overall efficiency. Mode 3 and 4 are much more common because they only require a synchronizable mains circuit breaker to parallel back to the utility once utility power is restored. As always, the ideal mode for any installation is determined by the unique needs of the facility.

### Island Operation

Island operation is common mostly in remote locations where the utility is either not available or not preferred. The defining characteristic of island operation is that the generator set is the only source of power. Operating in complete isolation from the utility might sound fairly straightforward, but this is actually not the case. Without the utility, the engine and genset controls must assume responsibility for everything. In circumstances like these, with no backup power source, the importance of a well-designed system with robust controls like the MIP and MMC cannot be overstated.

There are actually two different modes of island operation, each placing slightly different requirements on the controls. “Single island” operation refers to an installation relying on one generator set, whereas “island parallel” operation refers to an installation utilizing multiple units running in parallel. In a single island installation, operators must carefully observe specific steps when loading the genset in order to avoid an overload. Without a supplemental source of utility power, an overload would result in a complete power outage. Additionally, the maximum power output of a generator set is highly dependent on gas quality, which can fluctuate.

Island parallel mode is preferable when one generator set is not enough to meet the load requirements of the facility or system redundancy is desired. Considering the remote nature of most island installations, and the occasional need to shut down a generator set for routine maintenance, building redundancy into the system is a wise move. Controls play a vital role in island parallel installations because they distribute the load between connected generator sets. As more generator sets are added, complexity increases, and the need for an additional layer of control—a plant control system—becomes necessary.

## BALANCE OF PLANT EQUIPMENT

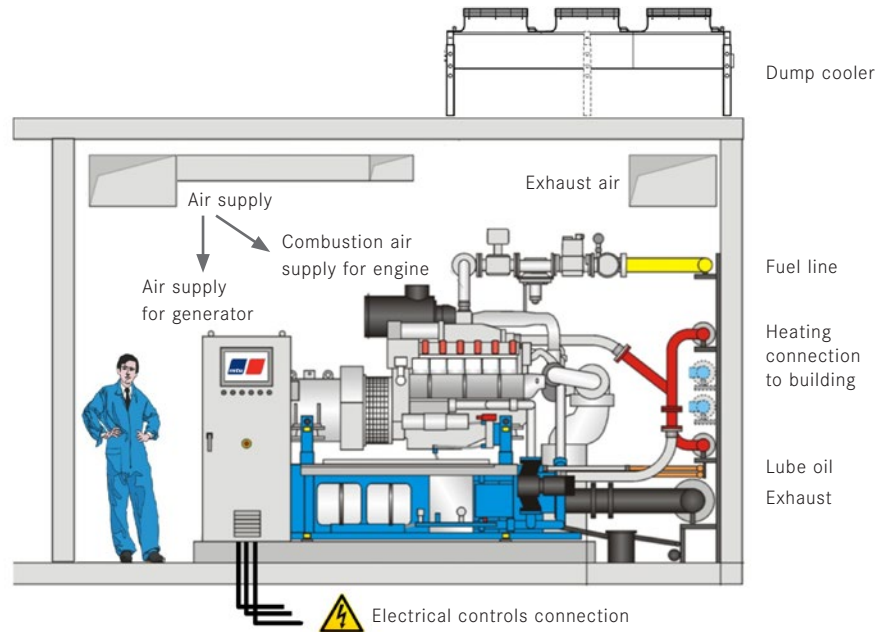

## CHP SYSTEM CONTROLS

CHP installations are far more complex than a typical standby/backup diesel generator installation, mainly due to the balance of plant requirements (e.g. pumps, valves, fuel lines, radiators, heat exchangers, etc.). Commonly, this equipment is locally sourced and installed, which means it's completely customized to meet the customer's demands.

An effective CHP system control, such as the MTU Module Control (MMC), must be highly customizable in order to work optimally with such a wide range of equipment. The MMC provides numerous customizable input/outputs to control balance of plant systems, including:

- // Heat recovery/hot water circuit - Controls how much additional engine heat is recaptured by heat exchanger for use in the facility by measuring water temperature in the heat recovery circuit and activating associated pumps, three-way control valves and radiators to attain desired temperature and flow.
- // Lubrication system - Automatically monitors engine oil levels via sensor (no dipstick) and activates fresh oil pump to replenish engine's lube oil supply as needed from an external tank.

- // Engine cooling and air/gas mixture cooling circuits - Controls how heat from the cooling circuits is used in the facility by measuring water temperature in the cooling circuits and activating associated pumps, three-way control valves and dump radiators to regulate temperatures and flow levels. Also monitors system data (ex. pressure and temperature) and provides status signals and alarms if expected limits are exceeded.

- // Air monitoring and room ventilation controls - Measures room temperature and controls ventilation fans to maintain optimal air flow based on external air temperatures and optimal temperatures for engine surface heat removal.

- // Biogas functions - Monitors pressure in biogas digester to regulate engine power. Controls gas compressor to ensure adequate fuel pressures for the engine, and activates flare when system is not in operation in order to prevent accumulation of excess biogas.

- // Safety functions - Critical input/outputs for smoke and gas leak detection systems, which can safely shut down the engine to avoid potential damage and risk.

Consolidating essential monitoring and control functions into one easy-to-use control helps operators keep the CHP installation running safely and reliably. Touchscreen interfaces with IPC and a customized, menu-based graphic user interface (GUI) help them be even more effective. Some controls, like the MMC and MIP, can be easily integrated to incorporate additional functions such as genset and mains protection and synchronization. Other common customization options include remote access via Internet, software interface (ex. Modbus), standby/island operation functions and other project specific requirements.



MMC touchscreen interface

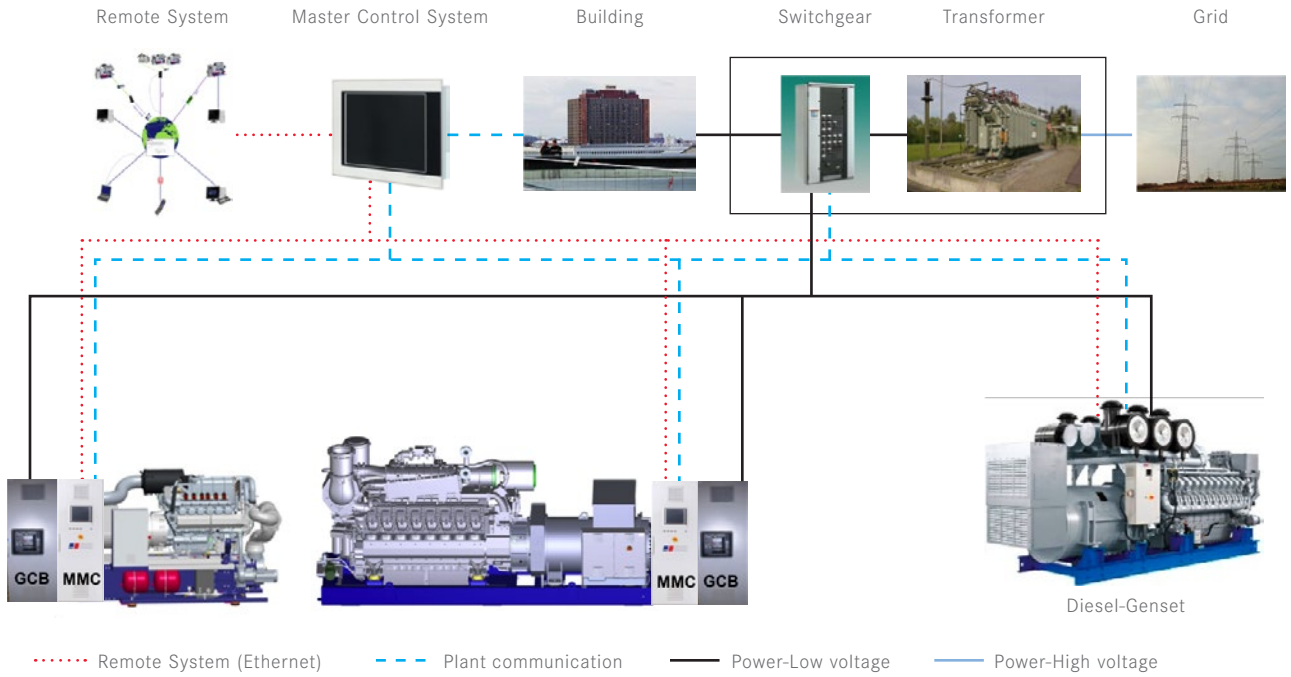

### PLANT CONTROLS

Multi-unit installations require an additional level of plant control, such as an MTU Master Control System (MCS), to tie everything together. Plant controls like the MCS provide complete functionality for facilities operating in island parallel mode with multiple units, or mains parallel mode with one or more CHP units and a diesel backup (for example).

Whatever the operating mode, plant control systems like the MCS integrate all of the individual units with the facility, assigning load to individual generator sets based on the power or heat requirements of the facility. They provide data visualization via IPC and data-logging, which helps operators visually evaluate equipment performance and assess operating conditions. Operators can choose whether to manage the entire plant or an individual generator set, all from the same control system. And with remote access interfaces, operators can manage the entire system remotely, providing invaluable flexibility.

### REMOTE ACCESS INTERFACES

Remote access capabilities can have a significant impact on CHP operations. They provide increased flexibility without compromising an operator’s ability to control the system, which can be especially advantageous if the operator is responsible for multiple locations or if they need to access the system in the middle of the night. Additionally, remote access enables third-party service partners responsible for equipment maintenance to proactively monitor and troubleshoot, if needed.

Remote access can typically be accomplished in one of two ways—either by setting up a software interface that ties the CHP controls directly into the facility’s SCADA master control system or setting up remote access through the Internet.

### Software interface for external communication

When bidirectional data exchange software between a CHP system controller and a facility's SCADA master control system is desired, software interfaces are an ideal solution. This setup enables the operator to control the generator set, including the load, power factor and voltage, all from within their facility's SCADA master control system. It also enables the CHP system to provide the master control system with vital feedback—information regarding the CHP unit and balance of plant including temperature, flows, operating conditions—transmitted through the software interface. Typical software interfaces include: Profibus DP, Ethernet (UDP), Modbus (RTU) via RS232 interface, Modbus (TCP), BACnet and PROFINET.

### Remote access through Internet

Some CHP system controllers such as the MMC can be connected directly to the Internet for remote access anytime, from anywhere in the world. The operator simply logs in via VNC over a standard Internet browser using their assigned username/password (with associated access level), to see a mirror image of the control system, just as if they were standing directly in front of the MMC touchscreen. The operator can then use their mouse to view system activity and adjust system parameters. If there is an alarm, the operator or service technician can log in and troubleshoot it.

Setting up remote access requires establishing an Internet connection on site (via standard modem/router) and configuring the Internet to work with router in the CHP controls (function with IPsec protocol). Remote access is typically a subscription service provided by the CHP system manufacturer or a certified distributor.

### CONCLUSION

Modern CHP installations are highly customized and extremely complex. Established CHP systems manufacturers such as MTU Onsite Energy are playing a leading role in developing automated control systems to improve operability by seamlessly integrating CHP engines and systems with balance of plant equipment. MTU Onsite Energy MIP and MMC control systems build upon 30 years of experience to offer complete functionality and flexibility for any installation.

### MTU Onsite Energy Corporation

Part of the Rolls-Royce Group

[www.mtuonsiteenergy.com](http://www.mtuonsiteenergy.com)



*MTU Onsite Energy is a brand of Rolls-Royce Power Systems. It provides diesel and gas-based power system solutions: from mission-critical to standby power to continuous power, heating and cooling. MTU Onsite Energy power systems are based on diesel engines with up to 3,250 kilowatts (kWe) power output and gas engines up to 2,530 kW.*

