

ELEVATION

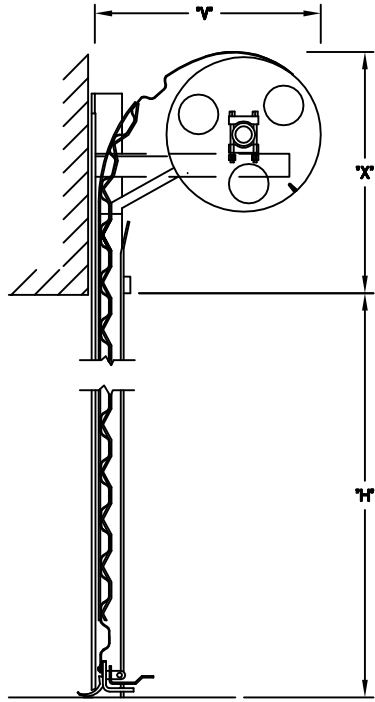

SECTION-A-A

SLIDE BOLT LOCK DETAIL

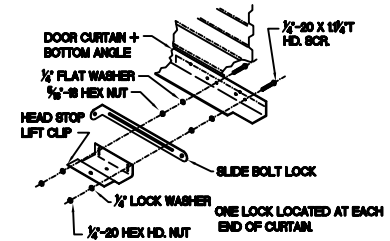

GUIDE DETAILS

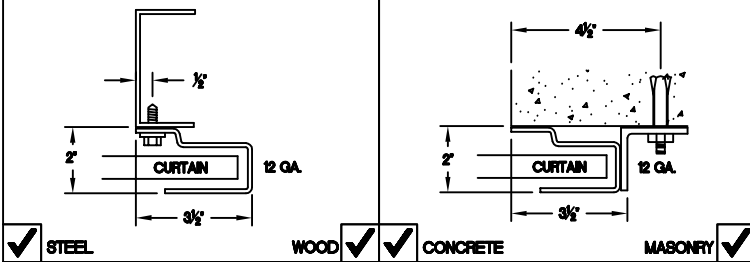

STANDARD CURTAIN

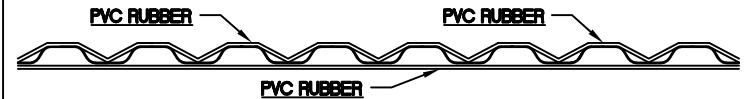

GENERAL NOTES:

- CURTAIN:**  
 26 GAUGE GALVANIZED STEEL WITH BAKED ON EPOXY PRIMER AND POLYESTER TOP COAT
- GUIDES:**  
 ROLL FORMED 12 GAUGE GALVANIZED STEEL
- OPERATION:**  
 RIGHT HAND SHOWN, LEFT HAND OPPOSITE
- OTHER SURFACES:**  
 GALVANIZED OR SHOP COAT PRIMER

SIDE ROOM REQUIREMENTS

<input checked="" type="checkbox"/>	CHOOSE TYPE OF OPERATION BELOW	SEE 'ELEVATION'	
<input type="checkbox"/>	HAND-ROPE PULL	A-1	A-2
<input type="checkbox"/>	REDUCTION GEAR CHAIN HOIST	7'	7'
<input type="checkbox"/>	ELECTRIC MOTOR OPERATOR KIT	10'	7'

MRK.	QTY.	OPENING SIZE		OPERATION	R.H.	CLEARANCES		OPTION	PROJECT:										
		WIDTH 'W'	HEIGHT 'H'			L.H.	'X'		'Y'	ARCHITECT:	CONTRACTOR:	DISTRIBUTOR:	DATE:	SHEET:	OF:	BY:	REF:#		



4255 McEver Industrial Dr.  
 Acworth, GA 30101  
 PH:(770) 974-2600  
 Fax:(770) 974-1455  
 www.astadoor.com

MODEL 201 HD COMMERCIAL SHEET DOOR

Asta Door Corporation is not responsible for the use of improper installation procedures, structural supports as well as field inspection prior to manufacturing and installation.

APPROVAL SIGNATURE: \_\_\_\_\_ DATE: \_\_\_\_\_