



**ASTA Door Corporation**

ASTA Door Corporation  
4255 McEver Industrial Drive  
Acworth, GA 30101  
Phone: (770) 974-2600  
Fax: (770) 974-1455  
Web Site: www.astadoor.com

## Installation Instructions

**Models: 201, 201HD, 202, 202HD, 203, 204 & 205**

USE ASTA DOOR CORPORATION PARTS ONLY - ALL OTHERS SHALL VOID WARRANTY

**IMPORTANT REMARKS** ALL ASTA PRODUCTS MUST BE INSTALLED BY A LICENSED, QUALIFIED PROFESSIONAL DOOR COMPANY TO QUALIFY FOR OUR WARRANTY. INSTALLATION WITHOUT PROPER TOOLS AND KNOWLEDGE CAN RESULT IN PERSONAL INJURY. THIS PAMPHLET IS DESIGNED TO ASSIST A PROFESSIONAL IN THE INSTALLATION OF ASTA 200 SERIES COMMERCIAL SHEET DOORS. SAFETY IS FOREMOST. INSTALLATION SHOULD BE EXECUTED BY LICENSED, QUALIFIED DOOR PROFESSIONALS. INSPECT ALL OF THE SHIPPED PARTS AND ACCOUNT FOR EVERYTHING BEFORE COMMENCING ANY WORK. FOR QUESTIONS AND TECHNICAL ASSISTANCE, CONTACT ASTA CUSTOMER SUPPORT AT (770) 974-2600.

## WARNING

MOVING DOOR can cause serious injury or death.  
Keep clear of opening while door is moving.



## SAFETY INSTRUCTIONS

1. Do **Not** stand or walk under moving door. Keep door in full view and free of obstructions while operating.
2. Do **Not** allow children to operate the door or automatic operator.
3. Repairs or adjustments should be made by a trained service person using proper tools and instructions.
4. To avoid injury, do not put fingers between door and guides.
5. Read owner's manual for your door and operator for more information.

**CAUTION:** USE CORRECT LIFTING PROCEDURES AND EQUIPMENT DURING INSTALLATION OF THIS PRODUCT TO AVOID INJURY OR DAMAGE.

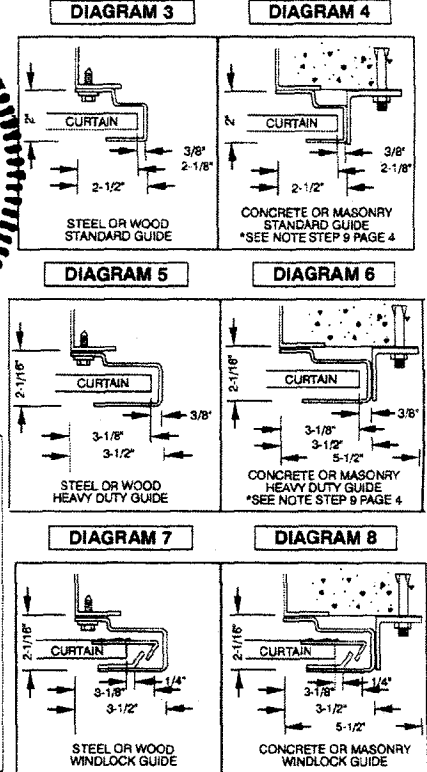
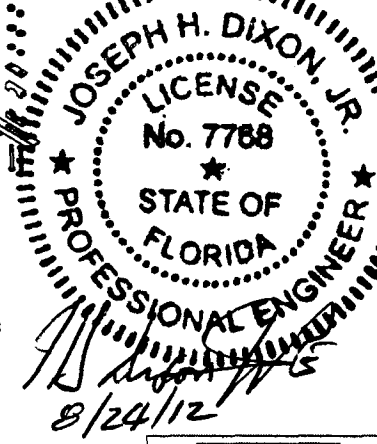
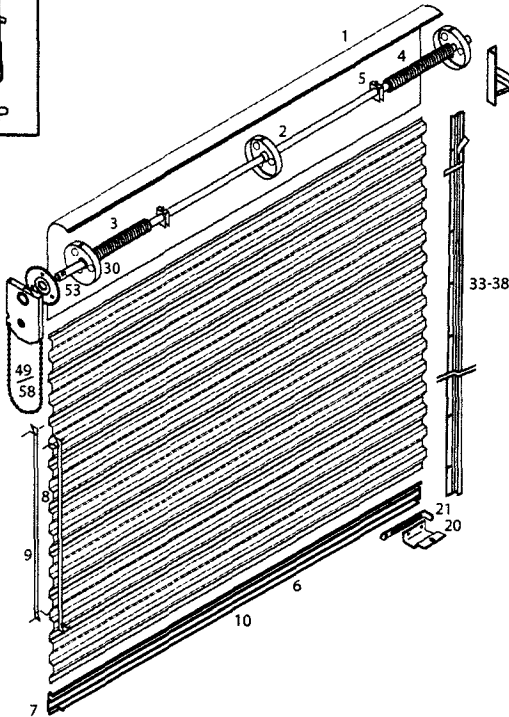
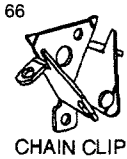

## PARTS LIST

1	VARIABLES	TOPSHEET
2	VARIABLES	AXLE PIPE
3	VARIABLES	SPRING-LH
4	VARIABLES	SPRING-RH
5	230003-1	SPRING CLAMP ASSEMBLY
6	VARIABLES	BOTTOM ANGLE
7	VARIABLES	BOTTOM RETAINER
8	VARIABLES	CORRUGATED STEEL SHEET
9	260000-1	CURTAIN SIDE WEAR STRIP, COMMERCIAL
10	260004-1	BULB ASTRAGAL, BOTTOM WEATHERSEAL
11	310103-1	AXLE CLAMP
12	310102-1	KEEPER PLATE, STANDARD 2 HOLE
13	420101-1	KEEPER PLATE, EXTENDED 4 HOLE
14	770301-1	U-BOLT, 3/8"-16
15	730103-1	HEX HEAD BOLT(GRS), 3/8"-24 X 3-1/2"
16	740104-1	HEX NUT, 3/8"-24
17	740103-1	HEX NUT, 3/8"-16
18	750103-1	FLAT WASHER, 3/8"
19	750203-1	LOCK WASHER, 3/8"
20	280301-1	DOOR STOP, LIFT CLIP
21	280104-1	SLIDE BOLT LOCK
22	730301-1	TRUSS HEAD SLOTTED BOLT, 1/4"-20
23	740201-1	SELF LOCKING NUT, 1/4"-20
24	750101-1	FLAT WASHER, 1/4"
25	740102-1	HEX NUT, 5/16"-18
26	410102-1	ROPE, 1/4"
27	420300-1	HAND CHAIN CLIP
28	420400-1	HAND CHAIN
29	750104-1	FLAT WASHER, 1-7/16"
30	220303-8B	12" DRUM ASSEMBLY W/BEARING

31	310200-1	SUPPORT BRACKET, RH
32	310300-1	SUPPORT BRACKET, LH
33	VARIABLES	DOOR GUIDE, 16GA STANDARD-LH
34	VARIABLES	DOOR GUIDE, 16GA STANDARD-RH
35	VARIABLES	DOOR GUIDE, 12GA HEAVY DUTY-LH
36	VARIABLES	DOOR GUIDE, 12GA HEAVY DUTY-RH
37	VARIABLES	DOOR GUIDE, 12GA WINDLOCK-RH
38	VARIABLES	DOOR GUIDE, 12GA WINDLOCK-LH
39	310400-1	MOUNTING PLATES, 3/16" STANDARD-PAIR
40	310410-1	MOUNTING PLATES, 1/4" HEAVY DUTY-PAIR
<b>MODELS 202, 202HD &amp; 204 ONLY:</b>		
41	260301-1	INSULATION, DOUBLE FOIL
42	260401-1	MYLAR TAPE, 2"
43	630002-1	TOP DRAFT STOP, 2-1/2" WIDE
44	850204-1	7/8" RETAINER FOR JAMB BRUSH SEAL
45	850211-1	2" JAMB BRUSH SEAL
<b>MODELS 203 &amp; 204 ONLY:</b>		
46	270501-1	WINDLOCK CLIP, COMMERCIAL
47	720101-1	POP RIVET, 3/16"
48	270502-1	WINDLOCK BACKER PLATE, COMMERCIAL
<b>DRIVES:</b>		
49	420103-1	4:1 POCKET WHEEL CHAIN HOIST ASSEMBLY:
50	420105-1	DRIVE SPROCKET, 41A40-3" (INCLUDED)
51	420113-1	MASTER LINK, #41 (INCLUDED)
52	420107-1	ROLLER CHAIN, #41 X 1.9" (INCLUDED)
53	260011-1	NYLON SPACER, BLACK (INCLUDED)
54	750203-1	LOCK WASHER, 3/8" (INCLUDED)
55	730106-1	HEX HEAD BOLT, 3/8"-16 X 1-1/2" (INCLUDED)

56	750103-1	FLAT WASHER, 3/8" (INCLUDED)
57	740103-1	HEX NUT, 3/8"-16 (INCLUDED)
58	420104-1	8:1 POCKET WHEEL CHAIN HOIST ASSEMBLY:
59	440001-1	DRIVE SPROCKET, 41A72-9" (INCLUDED)
60	420113-1	ROLLER CHAIN, #41 X 3.2" (INCLUDED)
61	420107-1	MASTER LINK, #41 (INCLUDED)
62	750203-1	LOCK WASHER, 3/8" (INCLUDED)
63	730106-1	HEX HEAD BOLT, 3/8"-16 X 1-1/2" (INCLUDED)
64	750103-1	FLAT WASHER, 3/8" (INCLUDED)
65	740103-1	HEX NUT, 3/8"-16 (INCLUDED)
66	420300-1	HAND CHAIN RETAINER CLIP (INCLUDED)
67	420299-1	HAND CHAIN OPEN LINK (INCLUDED)
68	440007-1	ELECTRIC OPERATOR (EO) KIT- <b>NOT INSTALLED</b> :
69	440001-1	DRIVE SPROCKET, 41A72-9" (INCLUDED)
70	750203-1	LOCK WASHER, 3/8" (INCLUDED)
71	730106-1	HEX HEAD BOLT, 3/8"-16 X 1-1/2" (INCLUDED)
72	750103-1	FLAT WASHER, 3/8" (INCLUDED)
73	740103-1	HEX NUT, 3/8"-16 (INCLUDED)
<b>FASTENERS</b>		
<b>STEEL JAMBS:</b>		
74	730702-1	TEK SCREW, #14 X 1" (GUIDE)
<b>WOOD JAMBS:</b>		
75	730403-1	WOOD LAG SCREW, 1/4" x 2" (GUIDE)
76	730402-1	WOOD LAG SCREW, 3/8" x 2" (BRACKET)
<b>MASONRY JAMBS:</b>		
77	760203-1	TAPCON SCREW, 1/4" X 1-3/4" (GUIDE-NO CLIPS)
78	760102-1	SLEEVE ANCHOR, 1/2" X 2-1/4" (GUIDE & BRACKET)

**CAUTION: DO NOT REMOVE THE PLASTIC BANDS WHICH HOLDS THE DOOR IN A ROLL.** YOU WILL BE TOLD AT A LATER TIME WHEN TO REMOVE IT. NO GUARANTEE WILL BE GIVEN OR RESPONSIBILITY ACCEPTED BY THE MANUFACTURER IF THE DOOR IS NOT INSTALLED AS INSTRUCTED. FOR PROPER OPERATION, FOLLOW THE INSTRUCTIONS AS GIVEN. PLEASE REVIEW ALL THE STEPS BEFORE BEGINNING.

### STEP #1 - PREPARATION

- CHECK THE HEIGHT AND WIDTH OF THE DOOR OPENING.
- CHECK IF THE DOOR JAMBS ARE PLUMB.
- CHECK IF THE FLOOR AND HEADER ARE LEVEL.
- CHECK THE DIMENSION PANEL FOR SIDE ROOM AND HEAD ROOM REQUIREMENTS. (SEE DIAGRAM 9)

DIAGRAM 9

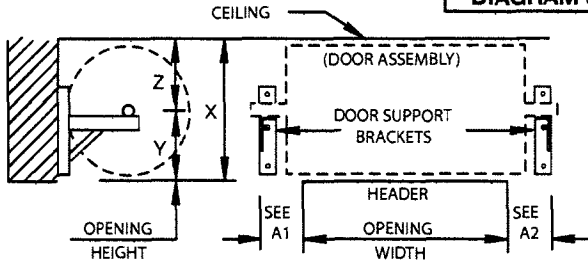

#### CLEARANCE REQUIREMENTS (HEADROOM)

HEIGHT	X	Y	Z
UP TO 8'-0	20"	9-1/2"	10"-1/2
UP TO 10'-0	21"	10"	11"
UP TO 16'-0	23"	11"	12"
UP TO 20'-0	24"	12"	12"

DRIVE TYPE	A1	A2
PUSH-UP / ROPE	6"	6"
POCKET WHEEL REDUCTION GEAR	9"	6"
ELECTRIC OPERATOR	9"	6"

#### NOTE

- DOORS WITH HEAVY DUTY GUIDES, ADD 1" TO A1 AND A2 DIMENSIONS.
- ALL WINDLOCK DOORS, ADD 1" TO A1 AND A2 DIMENSIONS.

### STEP #2 - INSTALL SUPPORT BRACKETS

- MARK THE HORIZONTAL (A1 & A2) OF THE SUPPORT BRACKETS (31-32).
- MARK THE VERTICAL DIMENSION OF THE SUPPORT BRACKET (DIMENSION "Y") BY USING A TRANSIT OR WATER LEVEL.  
**THE DOOR MUST BE LEVEL.**
- DRILL HOLES AND FASTEN THE BRACKETS WITH THE PROPER WALL FASTENERS REQUIRED TO OBTAIN A SOLID MOUNTING. USE THROUGH BOLTS ON SOFT BLOCK OR BRICK.

VERIFY THE MINIMUM HEADROOM REQUIREMENT, DIMENSION "X." IF INSUFFICIENT, LOWER THE BRACKETS UNTIL "X" IS OBTAINED. IF THE BRACKET IS LOWERED BY MORE THAN 2" THIS WILL REDUCE THE OPENING HEIGHT. THE GUIDE HEIGHT SHOULD ALSO BE REDUCED ACCORDINGLY.

#### NOTE

- DOORS WITH HEAVY DUTY GUIDES, ADD 1" TO A1 AND A2 DIMENSIONS.
- ALL WINDLOCK DOORS ADD 1" TO A1 AND A2 DIMENSIONS.
- NOTE PROPER BRACKET LOCATION AND PROVIDE ADEQUATE BACKING.

### STEP #3 - DRIVE INSTALLATION

- INSTALL ROPE (IF EQUIPPED) AS FOLLOWS.

- THREAD 1/4" ROPE THROUGH HOLE PROVIDED IN THE CENTER OF THE BOTTOM ANGLE.

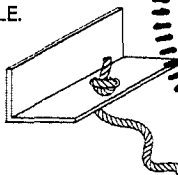

DIAGRAM 10

- INSTALL THE 4:1 POCKET WHEEL REDUCTION GEAR CHAIN HOIST (IF EQUIPPED) AS FOLLOWS:

- INSTALL DRIVE SPROCKET (50) ON PREFERRED SIDE USING 3/8" X 1 1/2" HEX BOLT. (55) AND 3/8" LOCK WASHER (54).
- REMOVE SPRING CLIP ON DRIVE SIDE AND DISCARD. SLIDE 1" NYLON SPACER (53) ONTO DOOR AXLE.
- SLIDE POCKET WHEEL ASSEMBLY (49) ONTO DOOR AXLE AND ALIGN SPROCKETS PARALLEL TO EACH OTHER.
- CONNECT DRIVE CHAIN (52) AROUND BOTH SPROCKETS USING THE MASTER LINK PROVIDED.
- AFTER DOOR TENSION HAS BEEN ADJUSTED (STEP 6), TIGHTEN SET SCREWS ON POCKET WHEEL ASSEMBLY.

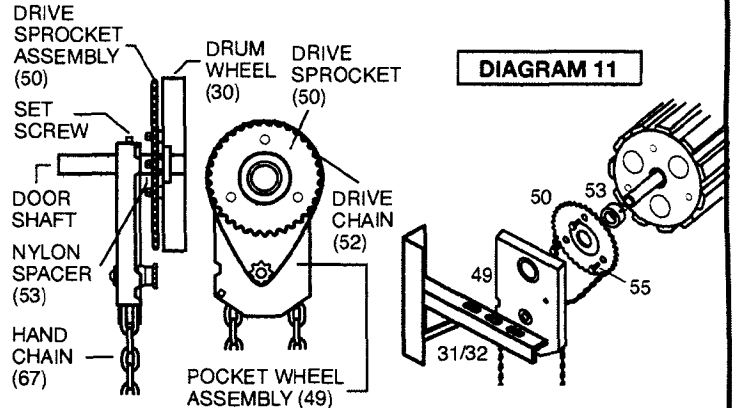

DIAGRAM 11

- INSTALL THE 8:1 POCKET WHEEL REDUCTION GEAR CHAIN HOIST (IF EQUIPPED) AS FOLLOWS.

- INSTALL DRIVE SPROCKET (59) ON PREFERRED SIDE USING 3/8" -16 X 1-1/2" HEX HEAD BOLTS (63), 3/8" LOCK WASHERS (62), 3/8" FLAT WASHERS (64), & 3/8"-16 HEX NUTS (65) PROVIDED.
- DO NOT REMOVE THE SPRING CLAMP (5) OR FLAT WASHER (29) THAT HOLDS DOOR IN POSITION ON THE DOOR AXLE.
- SLIDE POCKET WHEEL ASSEMBLY (58) ONTO DOOR AXLE AND ALIGN SPROCKETS PARALLEL TO EACH OTHER.
- CONNECT DRIVE CHAIN (60) AROUND BOTH SPROCKETS USING THE MASTER LINK PROVIDED.
- AFTER DOOR TENSION HAS BEEN ADJUSTED (STEP 6), TIGHTEN SET SCREWS ON POCKET WHEEL ASSEMBLY.

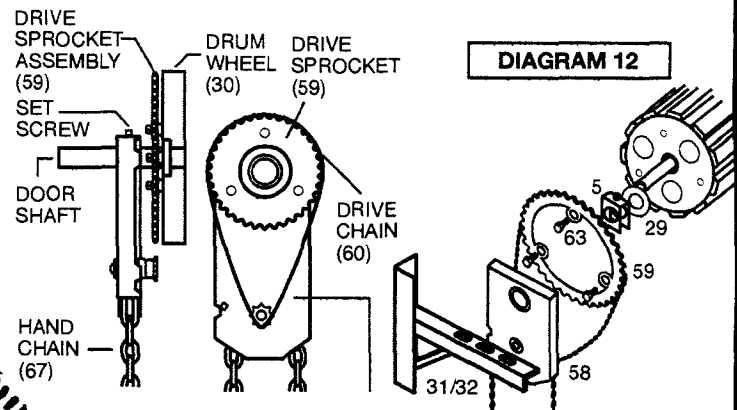

DIAGRAM 12

- INSTALL ELECTRIC OPERATOR KIT (IF EQUIPPED) AS FOLLOWS.

INSTALL E.O.... SPROCKET (69) TO THE END DRUM OF DOOR ON PREFERRED SIDE USING 3/8" X 1 1/2" HEX BOLT (71), 3/8" NUTS (73) AND 3/8" LOCK WASHER (70).

SLIDE FLAT ROUND WASHER (29) AND SPRING CLAMP ASSEMBLY (5) ONTO DOOR AXEL AND SECURE SET SCREW WITH CLAMP AND WASHER AGAINST BEARING OF THE END DRUM.

DIAGRAM 13

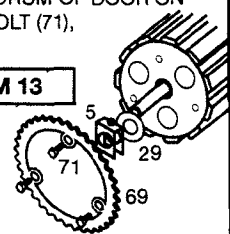

STATE OF FLORIDA  
 PROFESSIONAL ENGINEER  
 No. 7768  
 8/24/12

### STEP #4 - POSITION DOOR ASSEMBLY

- A. PLACE THE AXLE CLAMP (11) ONTO DOOR SUPPORT BRACKET. LIFT THE DOOR ASSEMBLY UP ONTO THE SUPPORT BRACKET. (SEE DIAGRAM 14).

**NOTE** POSITION THE DOOR AS CLOSE TO THE HEADER AS POSSIBLE. ALLOW ROOM TO SPIN THE DOOR. DO NOT ALLOW THE DOOR CURTAIN TO SCRAPE THE HEADER. **DO NOT USE FORKLIFTS OR GENIE LIFTS WITH UNPROTECTED ARMS/FORKS. THIS CAN CAUSE IRREPARABLE DAMAGE TO DOOR CURTAIN.**

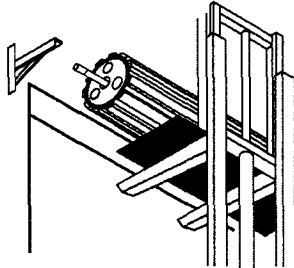

DIAGRAM 14

### STEP #5 - AXLE HARDWARE

#### A. MANUAL PUSH-UP/ROPE DRIVE:

1. PLACE THE AXLE CLAMP (11) ONTO HORIZONTAL MEMBER OF THE SUPPORT BRACKET (31,32) AND UNDER THE DOOR AXLE.
2. PLACE 3/8" U-BOLT (14) OVER DOOR AXLE AND THROUGH AXLE CLAMP.
3. FASTEN U-BOLT USING 3/8" NUT (17), 3/8" FLAT WASHER (18) AND 3/8" LOCK WASHER (19) ---TIGHTEN SECURELY.

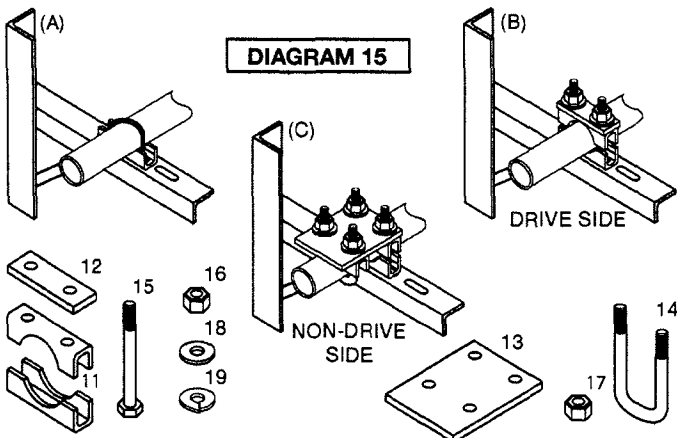

DIAGRAM 15

#### B. DRIVE SIDE FOR POCKET WHEEL REDUCTION DRIVE CHAIN HOIST AND E.O KITS:.

1. PLACE THE AXLE CLAMP (11) ONTO THE SUPPORT BRACKET (31,32) AND UNDER THE DOOR AXLE.
2. PLACE AXLE CLAMP (11) AND STANDARD KEEPER PLATE (12) ON TOP OF THE DOOR AXLE AS SHOWN.
3. FASTEN AXLE CLAMPS AND STANDARD KEEPER PLATE TOGETHER USING 3/8" X 3 1/2" HEX BOLTS (15), 3/8" LOCK WASHERS (19), 3/8" FLAT WASHERS (18), AND 3/8" NUTS (FINE THREAD) (16) --- TIGHTEN SECURELY.

**NOTE** REQUIRES A MINIMUM OF 40 LBS.... TORQUE TO PROPERLY SECURE HARDWARE.

#### C. NON-DRIVE SIDE FOR POCKET WHEEL REDUCTION DRIVE CHAIN HOIST AND EO KITS:

1. PLACE AXLE CLAMP (11) ONTO THE SUPPORT BRACKET (31,32) AND UNDER THE DOOR AXLE.
2. PLACE 2 AXLE CLAMPS (11) AND EXTENDED KEEPER PLATE (13) ON TOP OF THE DOOR AXLE AS SHOWN.
3. FASTEN AXLE CLAMPS USING 3/8" X 3 1/2" HEX BOLTS (15), 3/8" NUTS (FINE THREAD) (16), 3/8" FLAT WASHERS (18), 3/8" LOCK WASHERS (19) TO ATTACH EXTENDED KEEPER PLATE AS SHOWN. TIGHTEN SECURELY.

### STEP #6 - PRE-TENSION SPRINGS

1. INSTALL CHAIN CLIP (66) APPROXIMATELY 4'0" ABOVE FLOOR ON CHAIN OPERATED DOORS. INSTALLATION MUST BE SECURE.
2. APPLY PRE-TENSION TO THE SPRINGS BY ROTATING THE DOOR TWO (2) TURNS IN A FORWARD DIRECTION (SEE DIAGRAM 16). THE BOTTOM ANGLE IS TO BE IN A 6 O'CLOCK POSITION.

DIAGRAM 16

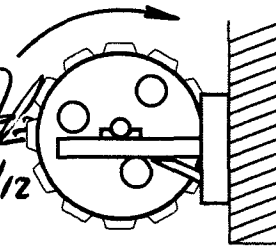

3. IF YOU'RE UNABLE TO ROTATE DOOR TO PRE-TENSION, USE A PIPE WRENCH TO ROTATE AXLE IN OPPOSITE DIRECTION. WITH ONE PERSON ON EACH SIDE OF DOOR, EACH PERSON SHOULD FIRMLY PLACE A LARGE PIPE WRENCH ON THE DOOR AXLE (SEE DIAGRAM 17). PULL DOWN TO APPLY TENSION INCREMENTALLY UNTIL YOU ACHIEVE TWO FULL ROTATIONS OF THE DOOR AXLE. THEN TIGHTEN THE AXLE HARDWARE.
4. REPEAT STEP C IF ADJUSTMENT IS NECESSARY.

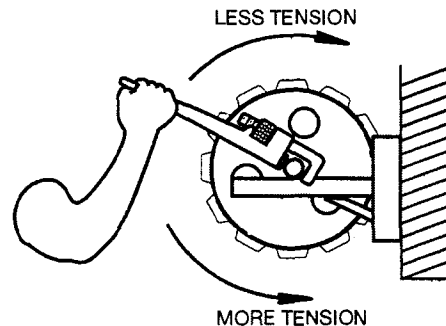

DIAGRAM 17

### STEP #7 - CUT THE BANDS

**WARNING** THE DOOR IS NOW UNDER TENSION. BEFORE CUTTING THE BANDS, TAKE HOLD OF THE DOOR ROLL BY THE BOTTOM ANGLE.

1. CUT THE BANDS AND BRING THE CURTAIN DOWN NO FURTHER THAN 1/4 THE HEIGHT OF THE DOOR OPENING. SECURE CHAIN OVER THE CHAIN RETAINER OR WEDGE A WOOD PROP BETWEEN THE BOTTOM ANGLE AND THE DOOR ROLL TO PREVENT UPWARD TRAVEL.

### STEP #8 - INSTALL DOOR STOPS (LIFT CLIPS) AND SLIDE BOLT LOCKS

1. INSTALL THE DOOR STOPS (20) AND THE SLIDE BOLT LOCKS (21) USING 1/4" X 1 1/4" TRUSS HEAD BOLT (22), 1/4" FLAT WASHERS (24), 5/16" NUT (25), AND 1/4" SELF LOCKING NUT (23) PER SIDE.
2. ELECTRONICALLY OPERATED DOORS STILL REQUIRE DOOR STOPS (LIFT CLIPS) TO BE INSTALLED.

**NOTE**

WHEN INSTALLING SLIDE BOLT LOCKS, THE THREADS FROM THE TRUSS HEAD BOLT PROTRUDING FROM THE SELF LOCKING NUT SHOULD BE REMOVED TO A FLUSH POSITION WITH THE SELF LOCKING NUT TO PREVENT DOOR FROM HANGING UP ON THE HEAD STOPS. CLAMP A PAIR OF VICE GRIPS ONTO THE THREAD AND BREAK OFF, IF NECESSARY.

DIAGRAM 18

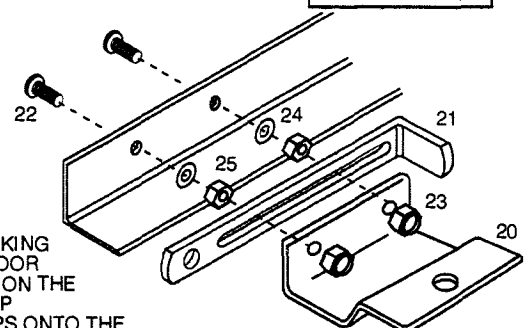

### STEP #9 - INSTALL DOOR GUIDES

- A. THE HEAD STOPS ON THE GUIDES SHOULD BE NO MORE THAN 1" HIGHER (TO BOTTOM OF STOPS) THAN THE DOOR HEADER. IF NOT, CUT THE BOTTOM OF THE GUIDES TO MATCH YOUR OPENING HEIGHT AND RELOCATE SLIDE BOLT NOTCH AT BOTTOM OF GUIDE.
- B. MODELS 201, 201HD, 202, 202HD, 205: RAISE THE DOOR CURTAIN SO THE BOTTOM ANGLE IS APPROXIMATELY 3" BELOW THE HEADER. SLIDE THE GUIDE OVER THE DOOR CURTAIN AND POSITION AGAINST THE DOOR OPENING ALLOWING 3/8" CLEARANCE FROM EDGE OF CURTAIN TO INSIDE THE GUIDE. INSTALL THE TOP FASTENERS. LOWER CURTAIN INTO GUIDES SLOWLY, MAINTAINING PROPER CLEARANCE AND STOP AT 6" ABOVE THE FLOOR. INSTALL BOTTOM FASTENERS. CHECK IF THE GUIDES ARE PLUMB USING A LEVEL. THE FASTENERS SHOULD BE LOCATED APPROXIMATELY EVERY 24" STARTING 6" FROM THE FINISHED FLOOR. INSTALL BALANCE OF FASTENERS AND BEND THE LEAD-IN AT THE TOP OF THE GUIDE TO A 45-DEGREE ANGLE.
- C. MODEL 203, 204: USE THE SAME PROCEDURE AS ABOVE ALLOWING 1/4" CLEARANCE BETWEEN CURTAIN AND THE WINDLOCK SPUR. BE SURE THERE IS SUFFICIENT CLEARANCE FOR THE WINDLOCK CLIPS TO ENTER THE GUIDES.
- D. FOR "WINDLOAD CERTIFIED DOORS" REFER TO SHOP DRAWING FOR FASTENER/ANCHOR TYPE AND FREQUENCY.
- E. SPRAY SILICONE LUBRICANT IN GUIDES FOR EASE OF OPERATION.

**NOTE** DOORS ORDERED FOR CONCRETE/MASONRY APPLICATIONS WILL INCLUDE 1/4" X 1-3/4" TAPCONS (77) FOR GUIDE INSTALLATION. BLOCK CLIPS WELDED TO BACK OF GUIDE FOR CONCRETE/MASONRY APPLICATION ARE OPTIONAL ON MODELS 201, 201HD, 202, 202HD AND 205. BLOCK CLIPS ARE STANDARD ON CONCRETE/MASONRY APPLICATION ON ALL MODELS 203 AND 204.

### STEP #10 - CHECK AND ADJUST BALANCE

IF DOOR LOWERS EASILY AND RAISES HARD, MORE TENSION IS REQUIRED. IF THE DOOR LOWERS HARD AND RAISES EASILY, LESS TENSION IS REQUIRED. (SEE DIAGRAM 17)

**CAUTION** FOR ALL DOOR DRIVES: BEFORE ADJUSTING THE SPRINGS, PULL THE DOORS INTO THE UP POSITION. SECURE THE DOOR BY THE FOLLOWING METHODS:

1. TIE A ROPE AROUND THE DOOR ROLL.
2. PLACE A CLAMP AT THE TOP OF THE GUIDE CHANNEL TO SECURE THE CURTAIN IN THE GUIDES.

**WARNING** WHEN THE AXLE CLAMPS ARE LOOSENED, THE SPRINGS WILL BE VERY STRONG. YOU WILL NEED TWO PEOPLE TO ADJUST THE DOOR TENSION SAFELY.

1. EACH PERSON SHOULD FIRMLY PLACE A LARGE PIPE WRENCH ON THE AXLE (SEE DIAGRAM (17)). LOOSEN THE AXLE CLAMPS AND PULL DOWN FOR MORE TENSION AND UP FOR LESS TENSION. FOR POCKET WHEEL REDUCTION DRIVE DOORS, REMEMBER TO LOOSEN SET SCREWS PRIOR TO ADJUSTMENT AND RETIGHTEN SECURELY AFTER ADJUSTMENT.
2. RETIGHTEN THE AXLE CLAMP HARDWARE.
3. REPEAT ABOVE STEPS IF FURTHER ADJUSTMENT IS NECESSARY. BEGIN AT STEP 6B.

### STEP #11 - TOP DRAFT STOP

- A. TOP DRAFT STOP COMES STANDARD WITH MODELS 202, 202HD AND 204 INSULATED DOORS. ALL OTHERS MODELS OPTIONAL.
- B. PULL DOOR DOWN AND LOCK. GO OUTSIDE AND MARK A LINE ON THE DOOR CURTAIN AS SHOWN (SEE DIAGRAM 20)
- C. RAISE DOOR 2'6" FROM FLOOR, OR UNTIL MARK IS ACCESSIBLE. PLACE TOP DRAFT STOP (43) IN POSITION AS SHOWN AND SECURE WITH TEK SCREWS. STRETCH RUBBER SLIGHTLY AND SECURE OTHER END. LOCATE AND INSTALL THE REMAINDER OF TEK SCREWS AT 12" O.C.

DIAGRAM 20

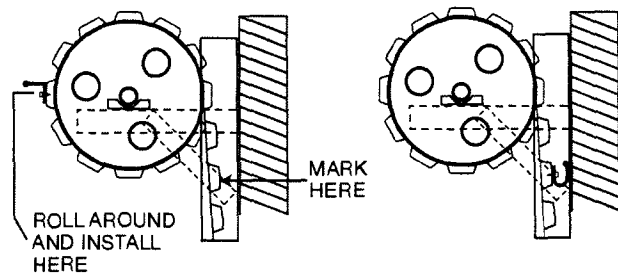
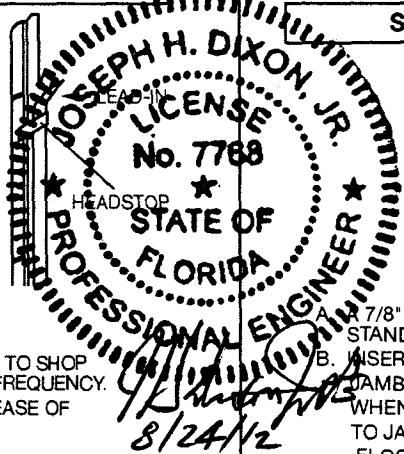
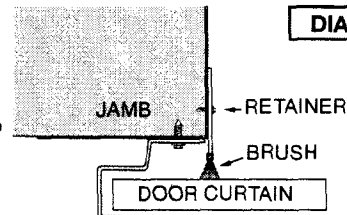

DIAGRAM 19



### STEP #12 - INSTALL JAMB BRUSH SEAL

DIAGRAM 21



7/8" ALUMINUM RETAINER AND 2" BRUSH COMES STANDARD WITH MODELS 202, 202HD AND 204.

- B. INSERT BRUSH INTO RETAINER. LINE UP RETAINERS ALONG JAMB SO THAT BRUSH SEAL FILLS THE DOOR CORRUGATION WHEN DOOR IS IN THE CLOSED POSITION. ATTACH RETAINER TO JAMB USING APPROPRIATE FASTENERS AT 6" FROM FLOOR AND HEADER AND 24" CENTERS MINIMUM.

### SERVICE AND MAINTENANCE HINTS

THE FOLLOWING HINTS WOULD HELP YOU TO OBTAIN FREE OPERATION.

- 1. DOOR CURTAIN DRAGS IN GUIDES**
  - A. CHECK THAT DOOR SUPPORT BRACKETS ARE PLUMB.
  - B. ADJUST LOCATION OF GUIDES FOR 3/8" - 1/4" SIDE CLEARANCE, TOP AND BOTTOM.
  - C. DOOR DRUM ASSEMBLY MAY BE SET TOO CLOSE OR TOO FAR FROM WALL. NOTE SLOTTED BRACKETS FOR ADJUSTMENT.
  - D. CHECK GUIDES FOR FOREIGN MATTER SUCH AS DIRT, ETC.
  - E. CHECK FOR DAMAGED GUIDES.
  - F. ADJUST LEAD-IN BEND AT TOP INSIDE OF GUIDES.
- 2. DOOR OPERATES HARD IN ONE DIRECTION**
  - A. CHECK ALL THE ABOVE POINTS.
  - B. RE-CHECK STEP NO. (10)
- 3. CHAIN JUMPS OFF CHAIN GEAR**
  - A. CHAIN GUIDE COULD BE BENT OUT OF ALIGNMENT WITH CHAIN WHEEL.
  - B. CHECK FOR DEFECTS IN POCKET WHEEL OR CHAIN.
  - C. ON ELECTRIC OPERATOR DOORS OR "POCKET WHEEL" REDUCTION GEAR DOORS, CHECK FOR SPROCKET ALIGNMENT AND PROPER CHAIN TENSION. ALSO CHECK THAT SET SCREWS ON POCKET WHEEL ASSEMBLY ARE SECURELY FASTENED.
- 4. DOOR DOES NOT CONTACT FLOOR LEVEL**
  - A. USE SPIRIT LEVEL TO CHECK WHETHER DOOR OR FLOOR IS OFF LEVEL. IF DOOR IS OUT OF LEVEL, PROCEED TO CHECK THE FOLLOWING POINTS:
    - B. CHECK IF "SUPPORT BRACKETS" AND GUIDES ARE LEVEL.
    - C. IF "A" AND "B" CHECK OUT, ROLL DOOR ALL THE WAY UP AND DOWN. SEE IF CURTAIN ROLLS UP STRAIGHT ONTO DRUMS. END OF DOOR SHOULD BE SQUARE. IF CONE SHAPED, GO TO SEC. 5.
- 5. DOOR DOES NOT ROLL UP STRAIGHT**
  - A. CHECK ALL POINTS IN SEC. 1.
  - B. AN ALTERNATIVE SOLUTION TO CORRECT THE CONING DOOR IS TO RAISE THE CURTAIN UP TO THE STOPS AND DETERMINE WHICH SIDE OF THE BOTTOM ANGLE TOUCHES THE STOPS FIRST.
  - C. SECURE HAND CHAIN, REMOVE GUIDES, LOWER CURTAIN DOWN TO FLOOR LEVEL. INSTALL A DRUM WEDGE ON SIDE OF THE DOOR FROM WHICH THE BOTTOM ANGLE TOUCHES FIRST.
  - D. PROCEED TO STEP 9 TO REINSTALL THE DOOR GUIDES.
  - E. IF PROBLEM PERSISTS, CONSULT FACTORY.