

BRACKET ATTACHMENT

CONCRETE/FILLED BLOCK VEDGE-BOLT, 3/8 X 1 3/4' LONG
 STEEL HEX BOLT, GR 5, 3/8-16 X 1 1/4' LONG OR 3/8-16 X 1' HVH
 TYPE 23 THREAD-CUTTING SCREW

(N) FOR PUSH-UP OPERATION 3 7/8"
 FOR HAND CHAIN OPERATION 4 5/8"
 FOR ELECTRIC OPERATION 5 3/8"
 FOR OUTSIDE OF CHAIN DRIVE 6 1/8"
 NOTE: RIGHT SIDE DRIVE SHOWN

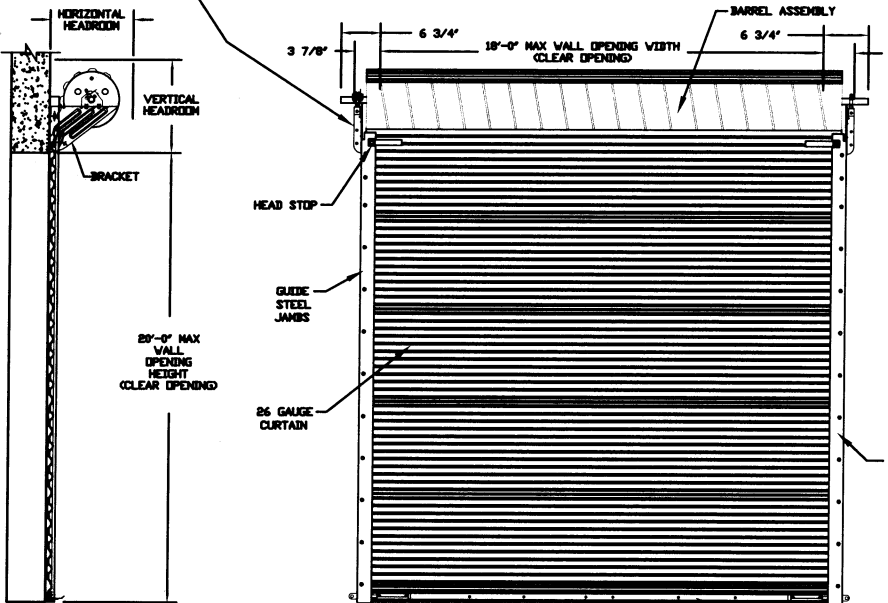

SIDE VIEW

INSIDE ELEVATION

HEADROOM REQUIRED		
OPENING HEIGHT	VERTICAL HEADROOM	HORIZONTAL HEADROOM
THRU 8'-0"	17"	19"
OVER 8'-0" THRU 10'-0"	19"	21"
OVER 10'-0" THRU 14'-0"	20"	22"
OVER 14'-0" THRU 16'-0"	21"	23"
OVER 16'-0" THRU 18'-0"	22"	24"
OVER 18'-0" THRU 20'-0"	23"	25"

ALLOWABLE TRANSVERSE DESIGN WIND LOADS (PSF)			
MAX DOOR WIDTH	MAX DOOR HEIGHT	DESIGN LOAD POSITIVE (PSF)	DESIGN LOAD NEGATIVE (PSF)
6'-0"	20'-0"	72.9	79.2
7'-0"	20'-0"	72.9	79.2
8'-0"	20'-0"	72.9	79.2
9'-0"	20'-0"	56.4	61.7
10'-0"	20'-0"	51.6	56.8
11'-0"	20'-0"	42.6	47.1
12'-0"	20'-0"	36.0	40.0
13'-0"	20'-0"	31.0	34.5
14'-0"	20'-0"	27.0	30.2
15'-0"	20'-0"	23.9	26.8
16'-0"	20'-0"	21.3	23.9
17'-0"	20'-0"	19.2	21.6
18'-0"	20'-0"	17.4	19.6

REVISIONS			
REV	DESCRIPTION	DATE	APPROVAL
-	DRAWING RELEASE	2-21-11	DM

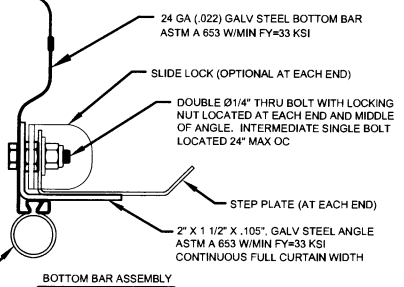
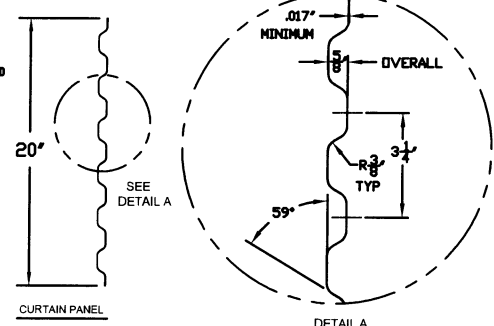
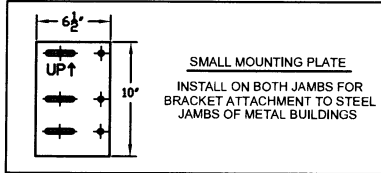
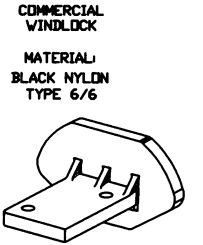
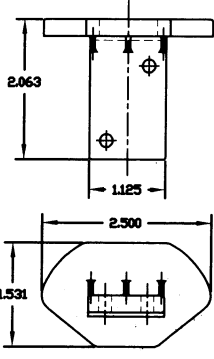
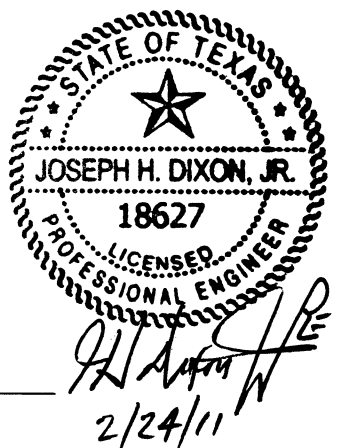

SEE SHEET 2 FOR NOTES

THESE CONFIDENTIAL DOCUMENTS SUBMITTED BY JANUS CONTAIN INFORMATION OF A PROPRIETARY NATURE AND MAY NOT BE REPRODUCED OR USED TO MANUFACTURE ANYTHING IN PART OR IN WHOLE FOR ANY PURPOSE OTHER THAN THAT WHICH IS NECESSARY FOR PREPARATION OF BIDS OF ENGINEERING WITHOUT THE EXPRESS PERMISSION OF JANUS WHICH MAY RECALL DOCUMENTS AT ANY TIME.

UNLESS OTHERWISE SPECIFIED DIMENSIONS ARE IN INCHES AND TOLERANCES ARE:

DECIMAL	FRACTIONS	ANGLES	HOLE DIAMETERS
.XX ±.03	± 1/16	± 0° 30'	UNDER .251 +.004 -.003
.XXX ±.005			.251 to .500 +.006 -.003
			OVER .500 +.008 -.003

PART NUMBER	NA
MATERIAL	NA
APPLIED FINISH	NA
PART OF HEADROOM	NA
APPROVALS	DATE
DRAWN BY	2-1-11
CHECKED	2-21-11
APPROVED	2-21-11

JANUS INTERNATIONAL CORPORATION
 134 JANUS INTERNATIONAL BLVD TEMPLE, GA 30179
 770-562-2850/Fax 770-562-2264
 © 2011 Janus International Corporation All Rights Reserved

CERTIFIED WIND LOAD RATED
 26 GA SERIES 3652 DOOR ASSEMBLY
 MAX SIZE 18'-0" X 20'-0"

SIZE: **B** DRAWING NUMBER: **T1014** REV: **-**
 SCALE: **NONE** SHEET: **1** OF: **2**

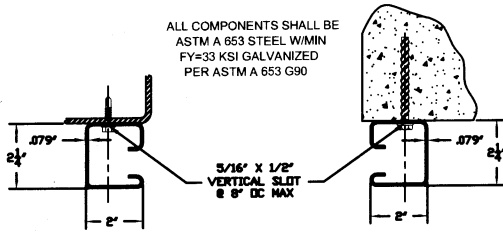

ALL COMPONENTS SHALL BE
ASTM A 653 STEEL W/MIN
FY=33 KSI GALVANIZED
PER ASTM A 653 G90

**GUIDE MOUNTED TO
STEEL JAMBS
USING 1/4-14 X 1'
SELF-DRILLING SCREW**

**GUIDE MOUNTED TO
CONCRETE/FILLED BLOCK JAMBS
USING 1/4\" X 3\" POWERS
WEDGE-BOLT DT**

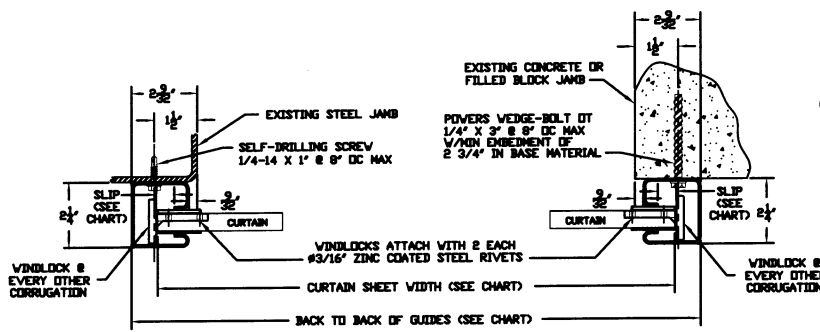

**STEEL JAMBS
LH GUIDE MOUNT SHOWN**

**CONCRETE/FILLED BLOCK JAMBS
RH GUIDE MOUNT SHOWN**

OPENING WIDTH	SLIP	CURTAIN SHEET WIDTH	BACK TO BACK OF GUIDES
57'-0"	3/8"	OPENING WIDTH + 2 3/16"	CURTAIN SHEET WIDTH + 2 3/8"
>7'-0" ≤ 9'-0"	1/2"	OPENING WIDTH + 2 7/16"	CURTAIN SHEET WIDTH + 2 1/8"
>9'-0" ≤ 18'-0"	21/32"	OPENING WIDTH + 2 3/4"	CURTAIN SHEET WIDTH + 1 13/16"

GENERAL NOTES

- THIS ROLL-UP DOOR SYSTEM IS DESIGNED IN ACCORDANCE WITH THE FLORIDA BUILDING CODE AND THE INTERNATIONAL BUILDING CODE. THE REQUIRED DESIGN WIND PRESSURES FOR A DOOR IN ANY PARTICULAR BUILDING SHALL BE DETERMINED IN ACCORDANCE WITH SECTION 1609 OF THE IBC. IN CODE JURISDICTIONS OUTSIDE OF FLORIDA, REQUIRED DESIGN WIND PRESSURES MAY BE DETERMINED IN ACCORDANCE WITH SECTION 1609 OF THE IBC OR WITH THE LOCAL BUILDING CODE IN EFFECT FOR THE SPECIFIC LOCATION.
- THIS ROLL-UP DOOR HAS BEEN SUCCESSFULLY TESTED ACCORDING TO THE UNIFORM STATIC AIR PRESSURE TEST PER ASTM E 230 AND ANSI/DASMA 108 TO SAFELY RESIST A POSITIVE AND NEGATIVE WIND LOAD AS NOTED BELOW. A TEST LOAD OF 1.5 X DESIGN LOAD HAS BEEN USED.

DESIGN LOAD = +36.0 PSF
-40.0

- WIND LOADS FOR BUILDING OPENINGS SHALL BE DETERMINED BY A PROFESSIONAL ENGINEER USING APPROPRIATE WIND SPEED AND DESIGN CRITERIA. THIS DOOR MAY BE USED WHERE THE DESIGN LOAD MEETS OR EXCEEDS THE DESIGN LOAD FOR THE BUILDING OPENING.
- SUPERIMPOSED LOADS ON THE JAMBS FROM THIS DOOR ARE DESIGNED AS Vx AND Vy HEREIN. CONTRACTORS SHALL HAVE BUILDING ENGINEER VERIFY ADEQUACY OF BUILDING STRUCTURE TO RESIST SUPERIMPOSED LOADS Vx, Vy.
- ALL WELDING SHALL BE PERFORMED BY QUALIFIED WELDERS IN ACCORDANCE WITH AWS SPECIFICATIONS, LATEST EDITION. ALL WELDING ELECTRODES SHALL CONFORM TO AWS A51 GRADE E-70.
- DOORS MAY BE PROVIDED WITH LOCK MECHANISMS AT THE OPTION OF THE OWNER.
- ALL BOLTS AND WASHERS SHALL BE GALVANIZED OR STAINLESS STEEL WITH A MINIMUM TENSILE STRENGTH OF 60 KSI.
- DESIGN BASED ON CERTIFIED TESTING LABORATORIES, INC., TEST REPORT NO. CTLA 8058V DATED FEBRUARY 17, 2011 (STATIC PRESSURE)
- ANCHOR NOTES:
 - EMBEDMENT LENGTH DOES NOT INCLUDE STUCCO FINISH.
 - FOR HOLLOW BLOCK, FILL ALL CELLS @ ANCHOR WITH 2500 PSI GROUT.
 - ANCHORS SHALL BE INSTALLED IN ACCORDANCE WITH MANUFACTURER'S SPECIFICATIONS.
- DOOR OPERATION TYPE TO BE PUSH-UP, HAND CHAIN, OR ELECTRIC.
- GUIDE TO JAMB ATTACHMENT FASTENERS IN WALL OPENING AREA BEGIN 4" FROM FLOOR AND END 4" BELOW THE TOP OF WALL OPENING.
- TEST DOOR WALL OPENING SIZE: 12'-0" X 8'-0".

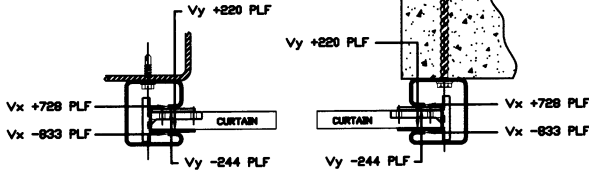

**STEEL JAMBS
LH GUIDE MOUNT SHOWN**

**CONCRETE/FILLED BLOCK JAMBS
RH GUIDE MOUNT SHOWN**

SUPERIMPOSED LOAD DIAGRAM

REVISIONS			
REV	DESCRIPTION	DATE	APPROVAL
-	DRAWING RELEASE	2-21-11	DM

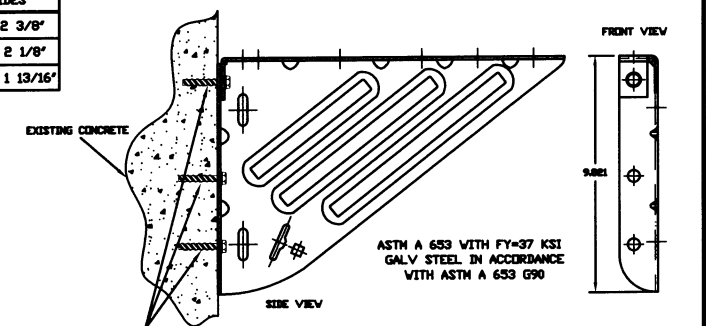
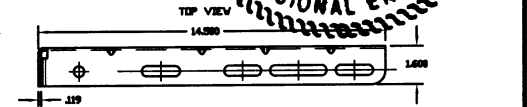
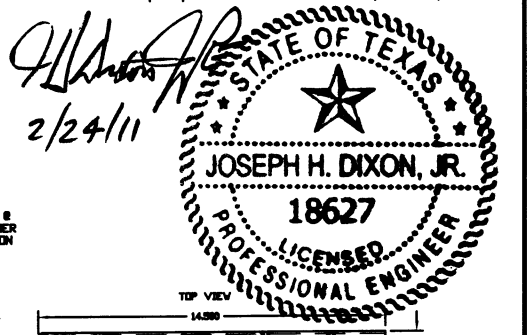

THREE #3/8\"/>

LH DOOR MOUNTING BRACKET DETAIL

THESE CONFIDENTIAL DOCUMENTS SUBMITTED BY JANUS CONTAIN INFORMATION OF A PROPRIETARY NATURE AND MAY NOT BE REPRODUCED OR USED TO MANUFACTURE ANYTHING IN PART OR IN WHOLE FOR ANY PURPOSE OTHER THAN THAT WHICH IS NECESSARY FOR PREPARATION OF THIS SET OF ENGINEERING WITHOUT THE EXPRESS PERMISSION OF JANUS WHICH MAY RECALL DOCUMENTS AT ANY TIME.

UNLESS OTHERWISE SPECIFIED DIMENSIONS ARE IN INCHES AND TOLERANCES ARE:

DECIMAL	FRACTIONS	ANGLES	HOLE DIAMETERS
.XX ±.03	± 1/16	± 0° 30'	UNDER .251 +.004 -.003
.XXX ±.005			.251 to .500 +.006 -.003
			OVER .500 +.008 -.003

PART NUMBER: NA	JANUS INTERNATIONAL CORPORATION	
MATERIAL: NA	134 JANUS INTERNATIONAL BLVD TEMPLE, GA 30179	
APPLIED FINISH: NA	770-562-2850/Fax 770-562-2264	
UNIT OF MEASURE: NA	© 2011 Janus International Corporation All Rights Reserved	
APPROVALS: DATE	CERTIFIED WIND LOAD RATED	
DRAWN: BECKY NELSON 2-1-11	26 GA SERIES 3652 DOOR ASSEMBLY	
CHECKED: DON MILLS 2-21-11	MAX SIZE 18'-0" X 20'-0"	
APPROVED: DON MILLS 2-21-11	SIZE: B	DRAWING NUMBER: T1014
	SCALED: NONE	SHEET: 2 OF 2

TEXAS DEPARTMENT OF INSURANCE

Engineering Services / MC 103-3A 333 Guadalupe Street P.O. Box 149104 Austin, Texas 78714-9104
Phone No. (512) 322-2212 Fax No. (512) 463-6693

PRODUCT EVALUATION GDR-72

Effective June 1, 2011

*The following product has been evaluated for compliance with the wind loads specified in the **International Residential Code (IRC)** and the **International Building code (IBC)**. This product shall be subject to reevaluation **June 2015**.*

This product evaluation is not an endorsement of this product or a recommendation that this product be used. The Texas Department of Insurance has not authorized the use of any information contained in the product evaluation for advertising, or other commercial or promotional purpose.

This product evaluation is intended for use by those individuals who are following the design wind load criteria in Chapter 3 of the IRC and Section 1609 of the IBC. The design loads determined for the building or structure shall not exceed the design load rating specified for the products shown in the limitations section of this product evaluation. This product evaluation does not relieve a Texas licensed engineer of his responsibilities as outlined in the Texas Insurance Code, the Texas Administrative Code, and the Texas Engineering Practice Act.

Series 3652 Rolling Doors, Non-Impact, as manufactured by:

Janus International Corporation
134 Janus International Blvd.
Temple, Georgia 30179-4435
(866) 562-2580
www.janusintl.com

will be accepted for use in designated catastrophe areas along the Texas Gulf Coast when installed in accordance with this product evaluation and the approved drawings that are referenced in this evaluation report.

PRODUCT DESCRIPTION

General: Janus Rolling Doors are made up of lock seamed together corrugated steel panels that span between the guides located on each side of an opening. The panels are constructed of 26 gauge material. The dimensions of the formed panels are $\frac{5}{8}$ " deep, $3\frac{1}{4}$ " corrugation pitch, and 20" panel height. The panels are manufactured from ASTM A 653 GR 80 zinc coated steel and are pre-painted with a full coat of primer and baked siliconized polyester finish coat. Windlocks are attached to both ends of every other corrugation. Guides are a roll formed steel shape. Bottom bar is single roll formed steel angle construction. Sheets 1 and 2 of the approved drawings show the details of the door construction, guides, various components, and specific door requirements based on curtain type, opening widths, and design pressure requirements.

LIMITATIONS

Design Drawings: The rolling doors shall be installed in accordance with Janus International Corporation drawing T1014, sheets 1 and 2 of 2, dated February 21, 2011, signed and sealed by Joseph H. Dixon, P.E. on February 24, 2011. The stated drawings will be referred to as approved drawings in this report. A copy of the approved drawings shall be available at the job site.

Wall Construction: The rolling doors may be mounted to the following types of wall framing:

- Cast-in-place concrete (minimum 3,000 psi)
- Grout-filled masonry CMU (minimum 2,500 psi grout)
- Steel, minimum $\frac{3}{16}$ " thick, A36

Maximum Opening Width: 18'-0"

Maximum Opening Height: 20'-0"

Glazing: Not permitted.

Allowable Design Pressure Rating: +17.4/-19.6 psf to +72.9/-79.2 psf. Refer to table on the approved drawings for the construction of the door and allowable span with the associated allowable design pressure rating.

Product Identification: A label will be affixed to the rolling door. The label shall include the name, series, or model number of the door; the name of the door manufacturer; the design pressure rating for the door; and compliance with either ASTM E 330 or ANSI/DASMA 108.

Impact Resistance: These door assemblies do not satisfy the Texas Department of Insurance's criteria for protection from windborne debris. These door assemblies will need to be protected with an impact protective system when installed in areas where windborne debris protection is required. The assemblies may be installed at any height on the structure as long as the design pressure rating for the assemblies is not exceeded.

Acceptance of Smaller Assemblies: Door assemblies with dimensions equal to or smaller than those specified above are acceptable within the limitations specified in this report.

INSTALLATION INSTRUCTIONS

General Installation Requirements: The rolling doors shall be installed in accordance with the manufacturer's installation instructions, the approved drawings, and this product evaluation report.

Anchorage: The rolling doors shall be anchored to the structure in accordance with the approved drawings. Anchorage of rolling doors to concrete, grout-filled CMU or steel shall follow the mounting details on the approved drawings and the fasteners specified in the mounting details. Minimum edge distances and minimum embedment depths for all fasteners that penetrate into the structure shall be as specified on the design drawings.

Note: The manufacturer's installation instructions and as build drawings shall be available on the job site during installation. All fasteners shall be corrosion resistant as specified in the International Residential Code (IRC) the International Building Code (IBC), and the Texas Revisions.