

CURTAIN PANEL  
 ASTM A653 GR 80 ZINC COATED STEEL  
 PRE-PAINTED WITH FULL COAT OF PRIMER AND  
 BAKED SILICONIZED POLYESTER FINISH COAT  
 26 GA CURTAIN DETAIL

REVISIONS			
REV	DESCRIPTION	DATE	APPROVAL
—	DRAWING RELEASE	11-14-02	DM
A	NOTE REVISIONS	4-16-04	DM
B	NOTE REVISIONS	6-17-09	CS

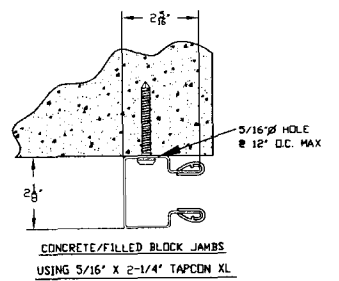

CONCRETE/FILLED BLOCK JAMBS  
 USING 5/16" X 2-1/4" TAPCON XL

ALL COMPONENTS SHALL BE  
 ASTM A653 STEEL W/MIN  
 FY=33 KSI GALVANIZED  
 PER ASTM A653 G-90

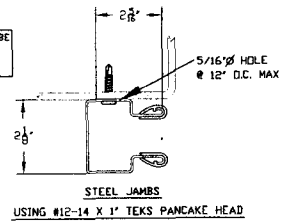

STEEL JAMBS  
 USING #12-14 X 1" TEKS PANCAKE HEAD  
 16 GA (.063) GUIDE MOUNTING DETAIL

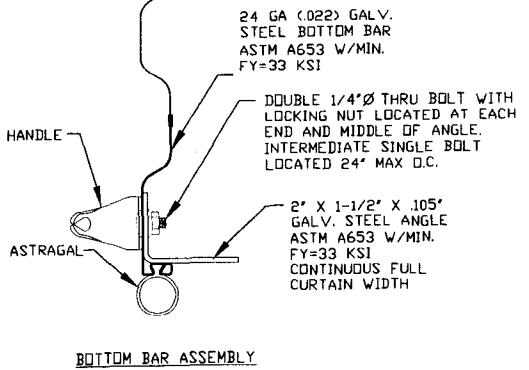

24 GA (.022) GALV.  
 STEEL BOTTOM BAR  
 ASTM A653 W/MIN.  
 FY=33 KSI  
 DOUBLE 1/4" Ø THRU BOLT WITH  
 LOCKING NUT LOCATED AT EACH  
 END AND MIDDLE OF ANGLE.  
 INTERMEDIATE SINGLE BOLT  
 LOCATED 24" MAX D.C.  
 2" X 1-1/2" X .105"  
 GALV. STEEL ANGLE  
 ASTM A653 W/MIN.  
 FY=33 KSI  
 CONTINUOUS FULL  
 CURTAIN WIDTH

OPENING HEIGHT	VERTICAL HEADROOM	HORIZONTAL HEADROOM
THRU 7'-4"	15-1/2"	17-1/2"
OVER 7'-4" THRU 8'-8"	16"	18"
OVER 8'-8" THRU 10'-0"	17"	18-1/4"

HEADROOM REQUIRED

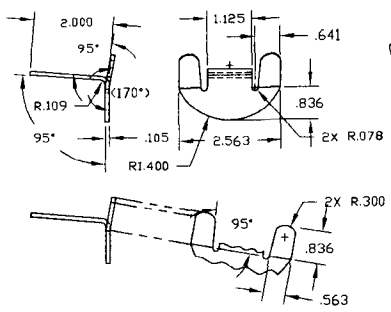

WINDLOCK  
 GALV. STEEL,  
 ASTM A653  
 WITH MIN.  
 FY=33KSI

THESE CONFIDENTIAL DOCUMENTS SUBMITTED BY JANUS CONTAIN INFORMATION OF A PROPRIETARY NATURE AND MAY NOT BE REPRODUCED OR USED TO MANUFACTURE ANYTHING IN PART OR IN WHOLE FOR ANY PURPOSE OTHER THAN THAT WHICH IS NECESSARY FOR PREPARATION OF BIDS OF ENGINEERING WITHOUT THE EXPRESS PERMISSION OF JANUS WHICH MAY RECALL DOCUMENTS AT ANY TIME.

UNLESS OTHERWISE SPECIFIED DIMENSIONS ARE IN INCHES AND TOLERANCES ARE:

DECIMAL	FRACTIONS	ANGLES	HOLE DIAMETERS
.XX ±.03	± 1/16	± 0° 30'	UNDER .251 +.004 -.003
.XXX ±.005			.251 to .500 +.006 -.003
			OVER .500 +.008 -.003

PART NUMBER:	
MATERIAL:	
APPLIED FINISH:	
UNIT OF MEASURE:	
APPROVALS	DATE
DRAWN: BECKY NELSON	11-14-02
CHECKED: DON MILLS	11-14-02
APPROVED: DON MILLS	11-14-02

**JANUS INTERNATIONAL CORPORATION**  
 134 JANUS INTERNATIONAL BLVD TEMPLE, GA 30179  
 770-562-2850/Fax 770-562-2264  
 © 2012 Janus International Corporation All Rights Reserved

CERTIFIED WIND LOAD RATED  
 26 GA SERIES 750 DOOR ASSEMBLY  
 MAX. SIZE 8'-8" X 12'-0"

SIZE: **B** DRAWING NUMBER: **T1002** REV: **B**

SCALE: NONE SHEET: 1 OF 2

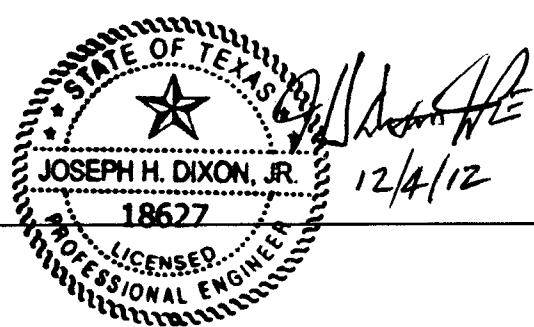

REVISIONS			
REV	DESCRIPTION	DATE	APPROVAL
	DRAWING RELEASE	11-14-02	DM
A	NOTE REVISIONS	4-16-04	DM
B	NOTE REVISIONS	6-17-09	CS

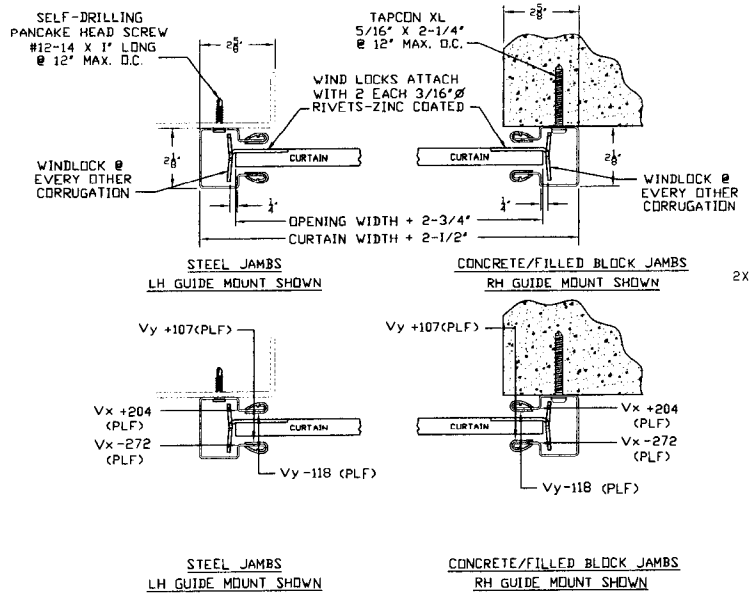

SUPERIMPOSED LOAD DIAGRAM

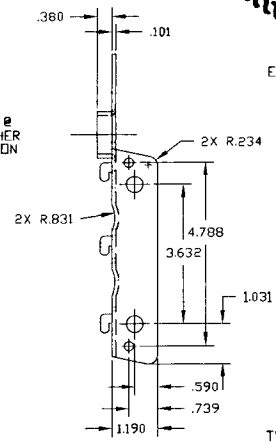

REAR VIEW

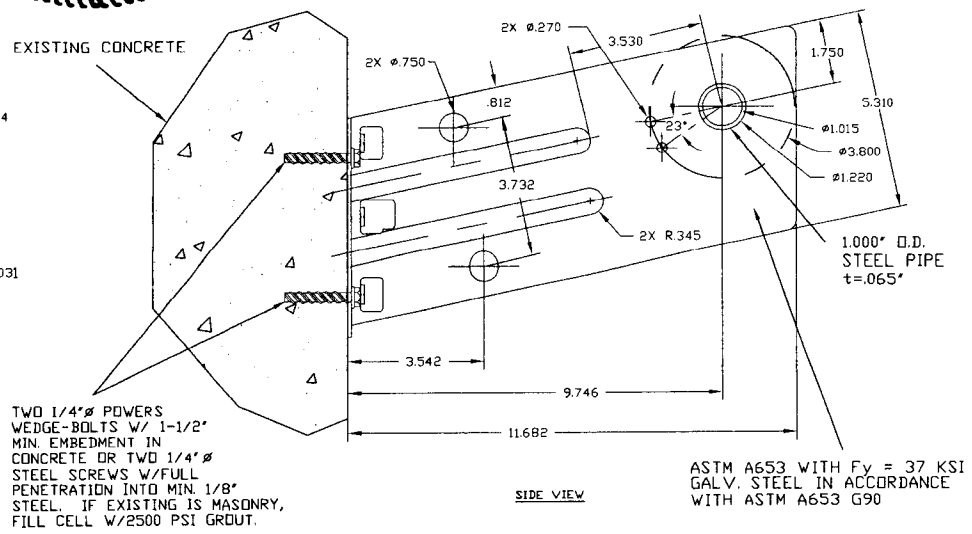

SIDE VIEW

TWO 1/4\"/>

ASTM A653 WITH Fy = 37 KSI GALV. STEEL IN ACCORDANCE WITH ASTM A653 G90

DOOR MOUNTING BRACKET DETAIL

GENERAL NOTES

- THIS ROLL-UP DOOR SYSTEM IS DESIGNED IN ACCORDANCE WITH THE FLORIDA BUILDING CODE.
- THIS ROLL-UP DOOR HAS BEEN TESTED IN ACCORDANCE WITH ASTM E-330 AND COMPLIES WITH ANSI/DASMA 108.

DESIGN LOAD =  $\begin{matrix} +24.4 \\ -27.0 \end{matrix}$  PSF

- WIND LOADS FOR BUILDING OPENINGS SHALL BE DETERMINED BY A PROFESSIONAL ENGINEER USING APPROPRIATE WIND SPEED AND DESIGN CRITERIA. THIS DOOR MAY BE USED WHERE THE DESIGN LOAD MEETS OR EXCEEDS THE DESIGN LOAD FOR THE BUILDING OPENING.
- SUPERIMPOSED LOADS ON THE JAMBS FROM THIS DOOR ARE DESIGNED AS Vx AND Vy HEREIN. CONTRACTORS SHALL HAVE BUILDING ENGINEER VERIFY ADEQUACY OF BUILDING STRUCTURE TO RESIST SUPERIMPOSED LOADS Vx, Vy AND BRACKET LOADS SHOWN.
- ALL WELDING SHALL BE PERFORMED BY QUALIFIED WELDERS IN ACCORDANCE WITH A.W.S. SPECIFICATIONS, LATEST EDITION. ALL WELDING ELECTRODES SHALL CONFORM TO A.W.S. A51 GRADE E-70.
- DOORS SHALL BE PROVIDED WITH LOCK MECHANISMS AT THE OPTION OF THE OWNER.
- ALL BOLTS AND WASHERS SHALL BE GALVANIZED OR STAINLESS STEEL WITH A MINIMUM TENSILE STRENGTH OF 60 KSI.

- DESIGN BASED ON CERTIFIED TESTING LABORATORIES, INC., TEST REPORT NO. CTLA - 983V-2
- ANCHOR NOTES:
  - EMBEDMENT LENGTH DOES NOT INCLUDE STUCCO FINISH.
  - FOR HOLLOW MASONRY, FILL ALL CELLS @ ANCHOR WITH 2500 PSI GROUT.
  - ANCHORS SHALL BE INSTALLED IN ACCORDANCE WITH MANUFACTURER'S SPECIFICATIONS.
- DOOR OPERATION TYPE TO BE PUSH-UP.

- GUIDE TO JAMB ATTACHMENT FASTENERS BEGIN 4\"/>

THESE CONFIDENTIAL DOCUMENTS SUBMITTED BY JANUS CONTAIN INFORMATION OF A PROPRIETARY NATURE AND MAY NOT BE REPRODUCED OR USED TO MANUFACTURE ANYTHING IN PART OR IN WHOLE FOR ANY PURPOSE OTHER THAN THAT WHICH IS NECESSARY FOR PREPARATION OF BIDS OF ENGINEERING WITHOUT THE EXPRESS PERMISSION OF JANUS WHICH MAY RECALL DOCUMENTS AT ANY TIME.

UNLESS OTHERWISE SPECIFIED DIMENSIONS ARE IN INCHES AND TOLERANCES ARE:

DECIMAL	FRACTIONS	ANGLES	HOLE DIAMETERS
.XX ±.03	± 1/16	± 0° 30'	UNDER .251 +.004 -.003
.XXX ±.005			.251 to .500 +.006 -.003
			OVER .500 +.008 -.003

PART NUMBER:	
MATERIAL:	
APPLIED FINISH:	
UNIT OF MEASURE:	
APPROVALS	DATE
DRAWN: BECKY NELSON	11-14-02
CHECKED: DON MILLS	11-14-02
APPROVED: DON MILLS	11-14-02

**JANUS INTERNATIONAL CORPORATION**  
 134 JANUS INTERNATIONAL BLVD TEMPLE, GA 30179  
 770-562-2850/Fax 770-562-2264  
 © 2012 Janus International Corporation All Rights Reserved

CERTIFIED WIND LOAD RATED  
 26 GA SERIES 750 DOOR ASSEMBLY  
 MAX. SIZE 8'-8" X 12'-0"

SIZE: **B** DRAWING NUMBER: **T1002** REV: **B**

SCALE: NONE SHEET: 2 OF 2

# TEXAS DEPARTMENT OF INSURANCE

Engineering Services / MC 103-3A 333 Guadalupe Street P.O. Box 149104 Austin, Texas 78714-9104  
Phone No. (512) 322-2212 Fax No. (512) 463-6693

---

## PRODUCT EVALUATION GDR-39

Effective Date: June 1, 2013

*The following product has been evaluated for compliance with the wind loads specified in the **International Residential Code (IRC)** and the **International Building Code (IBC)**. This product shall be subject to reevaluation **December 2013**.*

*This product evaluation is not an endorsement of this product or a recommendation that this product be used. The Texas Department of Insurance has not authorized the use of any information contained in the product evaluation for advertising, or other commercial or promotional purpose.*

*This product evaluation is intended for use by those individuals who are following the design wind load criteria in Chapter 3 of the IRC and Section 1609 of the IBC. The design loads shall not exceed the allowable wind loads shown in this product evaluation. This product evaluation does not relieve a Texas licensed engineer of his responsibilities as outlined in the Texas Insurance Code, the Texas Administrative Code and the Texas Engineering Practice Act.*

**Series 750 Steel Roll Up Doors, Non-impact Resistant**, as manufactured by:

**Janus International Corporation**  
**134 Janus International Blvd.**  
**Temple, Georgia 30179-4435**  
**(770) 562-2850**  
**[www.janusintl.com](http://www.janusintl.com)**

will be accepted for use in designated catastrophe areas along the Texas Gulf Coast when installed in accordance with this product evaluation and drawings that are referenced in this evaluation report.

## PRODUCT DESCRIPTION

This evaluation report is for the Series 750 steel roll up doors. The steel roll-up doors consist of a corrugated steel curtain that is suspended from a barrel. Coil springs, located within the barrel, raise and lower the curtain, which wraps around the barrel. The steel curtain is raised by push-up, hand chain, or electric operation. The sides of the curtain are constrained from lateral movement along their vertical edges by steel guides that are attached to the structure. The steel roll up doors specified in this evaluation report are non-impact resistant. This evaluation report includes the following doors:

System	Description	Maximum Width	Maximum Height
1	26 Gauge Series 750 Roll Up Doors; Single Curtain	3'-0"	12'-0"
2	26 Gauge Series 750 Roll Up Doors; Single Curtain	6'-0"	12'-0"
3	26 Gauge Series 750 Roll Up Doors; Single Curtain; Windlocks	8'-8"	12'-0"
4	26 Gauge Series 750 Roll Up Doors; Single Curtain; Windlocks	10'-0"	12'-0"

The steel roll up doors specified in this evaluation report consist of the following components:

**Curtain:** 26 gauge corrugated steel that is roll-formed from ASTM A 653 grade 80 steel. The corrugated sheets are galvanized and pre-painted with silicone polyester paint. The corrugated sheets are interlocked mechanically to form the curtain.

**Guides (Systems 1 and 2):** 18 gauge roll-formed from ASTM A 653 steel. The dimensions of the guide are  $1\frac{3}{32}$ " x  $1\frac{19}{32}$ ".

**Guides (Systems 3 and 4):** 16 gauge roll-formed from ASTM A 653 steel. The dimensions of the guide are  $2\frac{1}{8}$ " x  $2\frac{5}{16}$ ".

**Bottom Bar (Systems 1 and 2):** One (1) 24 gauge galvanized steel bottom bar full length of curtain. One (1) roll-formed steel angle, 2" x  $1\frac{1}{2}$ " x 0.105" x full length. The steel angle is attached to the steel bottom bar with  $\frac{1}{4}$ " diameter thru bolts and lock nuts. One bolt is located at each end and two (2) bolts are located at the center. A continuous vinyl bulb astragal is attached to the bottom of the steel angle.

**Bottom Bar (Systems 3 and 4):** One (1) 24 gauge galvanized steel bottom bar full length of curtain. One (1) roll-formed steel angle, 2" x  $1\frac{1}{2}$ " x 0.105" x full length. The steel angle is attached to the steel bottom bar with  $\frac{1}{4}$ " diameter thru bolts and lock nuts. Two (2) bolts are located at each end and two (2) bolts are located at the center. One (1) bolt is located 24 inches on center. A continuous vinyl bulb astragal is attached to the bottom of the steel angle.

**Windlocks (Systems 3 and 4):** 12 gauge galvanized steel. The windlock is attached to each side of the curtain at every other corrugation. Each windlock is attached to the curtain with two (2)  $\frac{3}{16}$ " diameter zinc coated rivets.

**Hardware:** Slide latch.

**Product Identification:** A label will be affixed to the bottom bar of the steel roll up door. The label shall include the manufacturer's name, model number of door, the allowable design pressure rating, the design drawing number, and compliance with either ASTM E 330 or ANSI/DASMA 108.

#### LIMITATIONS

System	Maximum Width	Maximum Height	Drawing	Design Pressure Rating (psf)
1	3'-0"	12'-0"	T1000 Rev. B	+35.0, -45.0
2	6'-0"	12'-0"	T1001 Rev. B	+19.9, -24.4
3	8'-8"	12'-0"	T1002 Rev. B	+24.4, -27.0
4	10'-0"	12'-0"	T1003 Rev. B	+19.4, -22.7

**Glazing:** None.

**Impact Resistance:** These door assemblies do not satisfy the Texas Department of Insurance's criteria for protection from windborne debris. These door assemblies will need to be protected with an impact protective system when installed in areas where windborne debris protection is required. The assemblies may be installed at any height on the structure as long as the design pressure rating for the assemblies is not exceeded.

**Acceptance of Smaller Assemblies:** Door assemblies with dimensions equal to or smaller than those specified above are acceptable within the limitations specified in this report.

**Drawings (The appropriate drawing listed below shall be available at the job site):**

**System 1:** Janus International Corporation; Certified Wind Load Rated 26 GA. Series 750 Door Assembly Max. Size 3'-0" x 12'-0"; Drawing No. T1000, Rev B; Sheet 1 and 2 of 2; revised 6-17-2009; signed, sealed, and dated 12-04-2012, by Joseph H. Dixon, P.E.

**System 2:** Janus International Corporation; Certified Wind Load Rated 26 GA. Series 750 Door Assembly Max. Size 6'-0" x 12'-0"; Drawing No. T1001, Rev B; Sheet 1 and 2 of 2; revised 6-17-2009; signed, sealed, and dated 12-04-2012, by Joseph H. Dixon, P.E.

**System 3:** Janus International Corporation; Certified Wind Load Rated 26 GA. Series 750 Door Assembly Max. Size 8'-8" x 12'-0"; Drawing No. T1002, Rev B; Sheet 1 and 2 of 2; revised 6-17-2009; signed, sealed, and dated 12-04-2012, by Joseph H. Dixon, P.E.

**System 4:** Janus International Corporation; Certified Wind Load Rated 26 GA. Series 750 Door Assembly Max. Size 10'-0" x 12'-0"; Drawing No. T1003, Rev B; Sheet 1 and 2 of 2; revised 6-17-2009; signed, sealed, and dated 12-04-2012, by Joseph H. Dixon, P.E.

## INSTALLATION INSTRUCTIONS

The steel roll up doors shall be installed to the substrate using one of the following methods (refer to the design drawings referenced above for further guidance):

**Bolted to cast-in-place, pre-cast concrete, or grout-filled CMU substrate:**

**Systems 1 and 2: Guide Mounting:** Each guide shall be anchored to the substrate with minimum  $\frac{1}{4}$ " x  $1\frac{3}{4}$ " Powers Wedge-Bolt anchors. The anchors shall be placed through the interior of the guide into the substrate. The anchors shall be spaced a maximum of 24 inches on center along the length of the guide through the pre-drilled holes in the guide. If the bolt must penetrate through a wall covering, then the bolt length shall be increased by the thickness of the wall covering material. The back end of the guide shall be located a minimum of  $1\frac{3}{32}$  inches away from the edge of the door opening. Grout shall be minimum 2,500 psi. **Tensioner Bracket Mounting:** Each bracket shall be anchored to the substrate with two (2) minimum  $\frac{1}{4}$ " diameter Powers Wedge-Bolt anchors with a minimum  $1\frac{1}{2}$ " embedment. If the bolts must penetrate through a wall covering, then the bolt length shall be increased by the thickness of the wall covering material.

**Systems 3 and 4: Guide Mounting:** Each guide shall be anchored to the substrate with minimum  $\frac{5}{16}$ " x  $2\frac{1}{4}$ " Tapcon XL anchors. The anchors shall be placed through the interior of the guide into the substrate. The anchors shall be spaced a maximum of 12 inches on center along the length of the guide through the pre-drilled holes in the guide. If the bolt must penetrate through a wall covering, then the bolt length shall be increased by the thickness of the wall covering material. The back end of the guide shall be located a minimum of  $2\frac{5}{8}$  inches away from the edge of the door opening. Grout shall be minimum 2,500 psi. **Tensioner Bracket Mounting:** Each bracket shall be anchored to the substrate with two (2) minimum  $\frac{1}{4}$ " diameter Powers Wedge-Bolt anchors with a minimum  $1\frac{1}{2}$ " embedment. If the bolts must penetrate through a wall covering, then the bolt length shall be increased by the thickness of the wall covering material.

**Bolted to steel substrate:**

**Systems 1 and 2: Guide Mounting:** The steel substrate shall be minimum  $\frac{1}{8}$ " thick A36 steel. Each guide shall be anchored to the substrate with minimum  $\frac{1}{4}$ "-14 x 1" self-drilling TEKS screws. The screws shall be placed through the interior of the guide into the substrate. The screws shall be spaced a maximum of 24 inches on center along the length of the guide through the pre-drilled holes in the guide. If the screws must penetrate through a wall covering, then the bolt length shall be increased by the thickness of the wall covering material. **Tensioner Bracket Mounting:** Each bracket shall be anchored to the substrate with two (2) minimum  $\frac{1}{4}$ " diameter steel screws with full penetration into the steel. If the screws must penetrate through a wall covering, then the screw length shall be increased by the thickness of the wall covering material.

**Systems 3 and 4: Guide Mounting:** The steel substrate shall be minimum  $\frac{1}{8}$ " thick A36 steel. Each guide shall be anchored to the substrate with minimum #12-14 x 1" self-drilling TEKS screws. The screws shall be placed through the interior of the guide into the substrate. The screws shall be spaced a maximum of 12 inches on center along the length of the guide through the pre-drilled holes in the guide. If the screws must penetrate through a wall covering, then the bolt length shall be increased by the thickness of the wall covering material. **Tensioner Bracket Mounting:** Each bracket shall be anchored to the substrate with two (2) minimum  $\frac{1}{4}$ " diameter steel screws with full penetration into the steel. If the screws must penetrate through a wall covering, then the screw length shall be increased by the thickness of the wall covering material.

**Note:** The manufacturer's installation instructions and the design drawings referenced in this evaluation report shall be available on the job site during installation. All fasteners shall be corrosion resistant as specified in the International Residential Code (IRC), the International Building Code (IBC), and the Texas Revisions.