

| REVISIONS | | | |
|-----------|----------------------------|---------|----------|
| REV | DESCRIPTION | DATE | APPROVAL |
| — | DRAWING RELEASE | 9-15-03 | DM |
| A | DADE COUNTY CHANGES | 1-16-04 | DM |
| B | GDE FAS SPA 10"-8.5" | 6-10-05 | DM |
| C | RETEST 8-5-2013 | 8-26-13 | CS |
| D | CO. NAME & FASTENER CHANGE | 6-5-17 | CS |

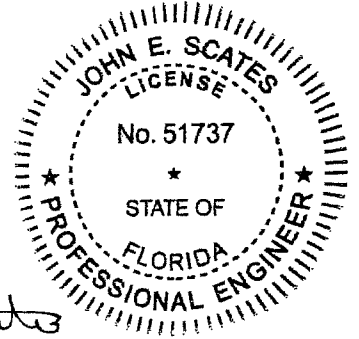
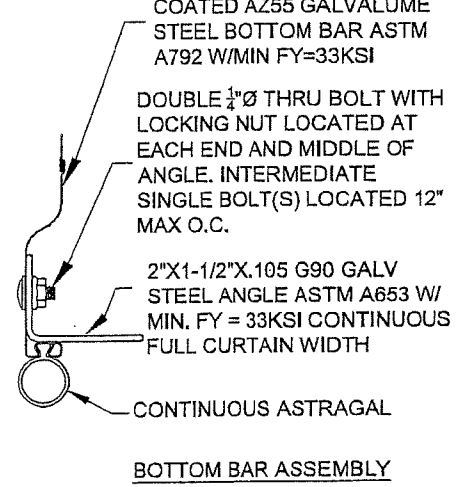
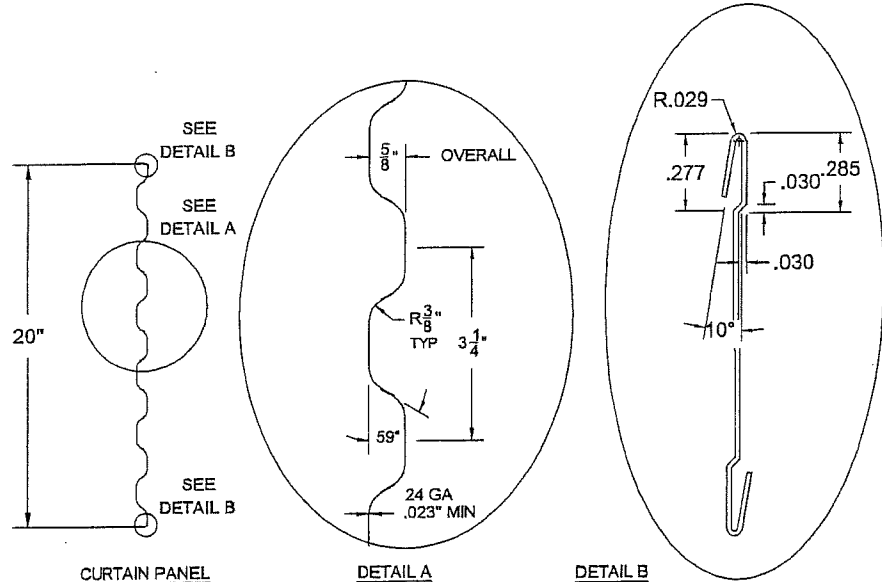
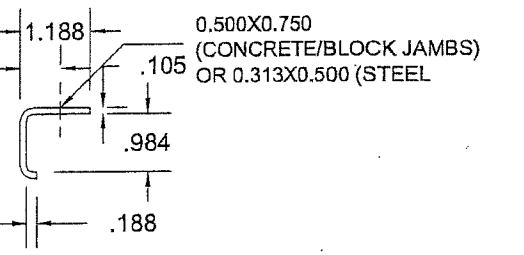
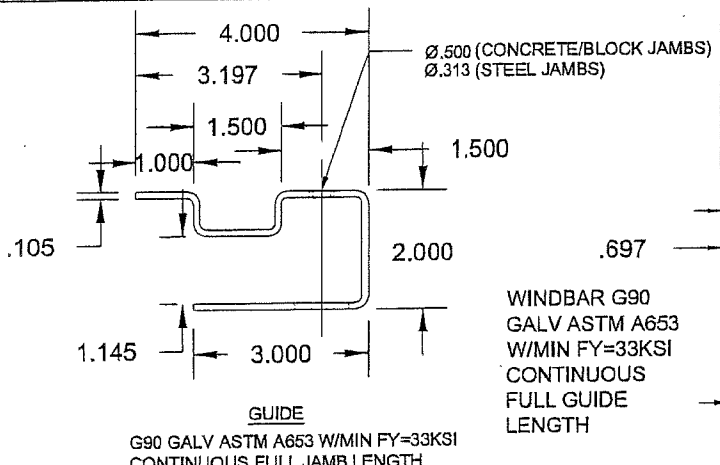
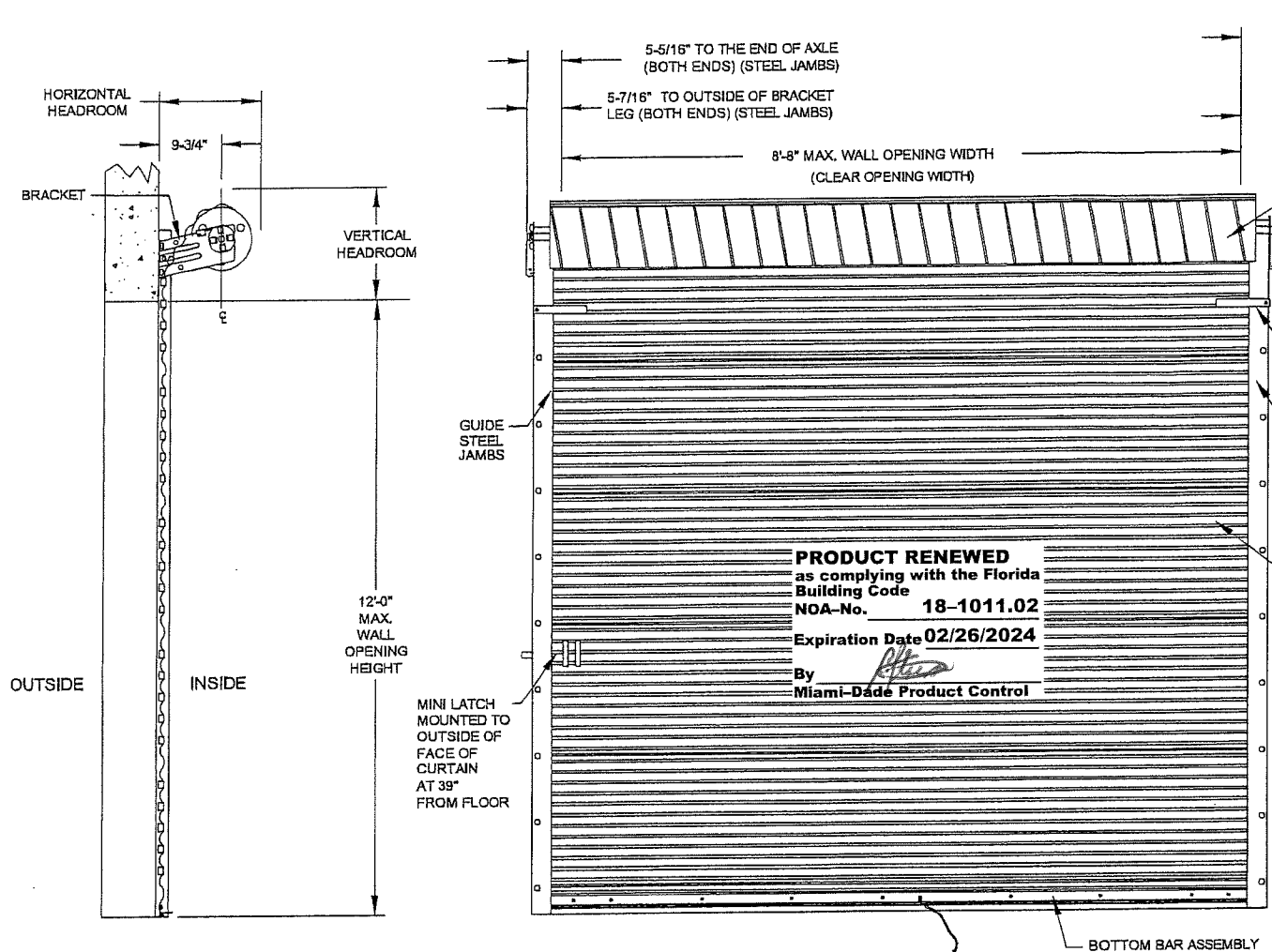

John E. Scates, P.E.
2560 King Arthur Blvd.
Lewisville, TX 75056
FL PE 51737

PRODUCT REVISED
as complying with the Florida Building Code
NOA-No. **18-0118.02**
Expiration Date **02/26/2019**
By *[Signature]*
Miami-Dade Product Control

Professional Engineer's seal provided only for verification of windload construction details.

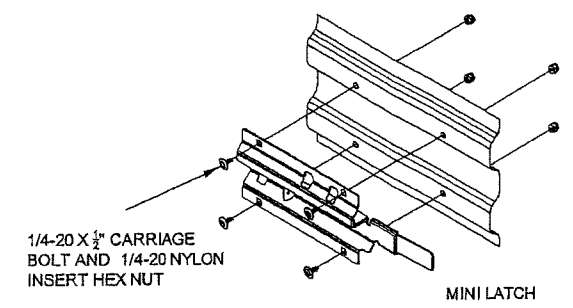
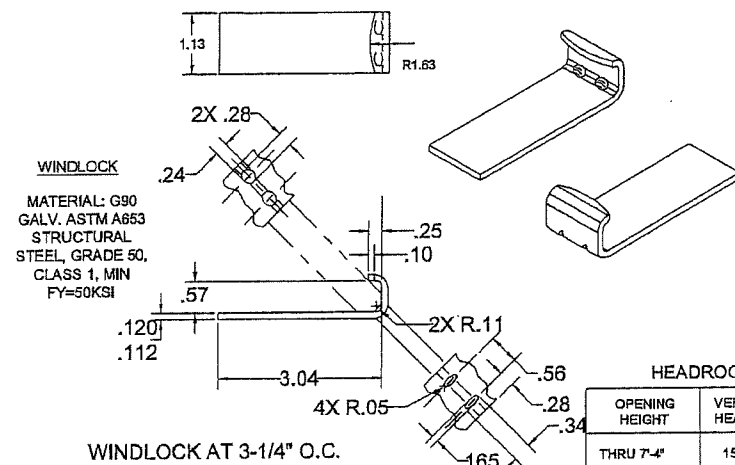

| HEADROOM REQUIRED | | |
|------------------------|-------------------|---------------------|
| OPENING HEIGHT | VERTICAL HEADROOM | HORIZONTAL HEADROOM |
| THRU 7'-4" | 15-1/2" | 17-1/2" |
| OVER 7'-4" THRU 8'-8" | 16" | 18" |
| OVER 8'-8" THRU 10'-0" | 17" | 18-1/4" |

| UNLESS OTHERWISE SPECIFIED DIMENSIONS ARE IN INCHES AND TOLERANCES ARE: | | | |
|---|-----------|----------|-------------------------------|
| DECIMAL | FRACTIONS | ANGLES | HOLE DIAMETERS |
| .XX ± 0.03 | ± 1/16 | ± 0° 30' | UNDER .251 +.004 -.003 |
| .XXX ± 0.005 | | | 0.251 to 0.500 +.006 -.003 |
| | | | OVER 0.500 +.008 -.003 |

| | |
|---------------------|---------------|
| PART NUMBER: NA | DATE: 7-25-03 |
| MATERIAL: NA | DATE: 9-15-03 |
| APPLIED FINISH: NA | DATE: 9-15-03 |
| UNIT OF MEASURE: NA | |
| DRAWN: BECKY NELSON | |
| CHECKED: DON MILLS | |
| APPROVED: DON MILLS | |

JANUS INTERNATIONAL GROUP, LLC
135 JANUS INTERNATIONAL BLVD. TEMPLE, GA 30179-4435
770-562-2850/Fax 770-562-2264
© 2018 Janus International Group, LLC. All Rights Reserved

DADE COUNTY MINI DOOR SERIES 850
MAX. SIZE 8'-8" X 12'-0"

SIZE **B** DRAWING NUMBER: **T1006** REV: **D**

SCALE: NONE SHEET: 1 OF 2

SEE SHEET 2 FOR NOTES

GENERAL NOTES

1. THIS ROLL-UP DOOR SYSTEM HAS BEEN SUCCESSFULLY TESTED ACCORDING TO THE UNIFORM STATIC AIR PRESSURE TEST PER TAS 202-94, THE LARGE MISSILE IMPACT TEST PER TAS 201-94 AND THE CYCLIC WIND PRESSURE LOADING TEST PER TAS 203-94, IN AN INDEPENDENT TESTING LAB CONFORMING TO TAS 301-94.
2. THE DOOR IS DESIGNED TO COMPLY WITH THE MIAMI-DADE COUNTY PRODUCT CONTROL DIVISION FOR THE HIGH VELOCITY HURRICANE ZONE (HVHZ) OF THE FLORIDA BUILDING CODE.
3. DESIGN LOAD RATING = +46.0 PSF POSITIVE WIND LOAD
-54.0 PSF NEGATIVE WIND LOAD
4. WIND LOADS FOR BUILDING OPENINGS SHALL BE DETERMINED BY A PROFESSIONAL ENGINEER USING APPROPRIATE WIND SPEED AND DESIGN CRITERIA. THIS DOOR MAY BE USED WHERE ITS DESIGN LOAD MEETS OR EXCEEDS THE DESIGN LOAD REQUIRED FOR THE BUILDING OPENING.
5. THE BUILDING ENGINEER SHALL VERIFY THE ADEQUACY OF THE BUILDING STRUCTURE TO WITHSTAND SUPERIMPOSED LOADS P_{xpf} , P_{ypl} + R_{ypl} , P_{xnf} and P_{ynf} + R_{ynf} .
6. ALL WELDING SHALL BE PERFORMED BY QUALIFIED WELDERS IN ACCORDANCE WITH THE LATEST EDITION OF AWS SPECIFICATIONS. ALL WELDING ELECTRODES SHALL CONFORM TO AWS A5.1, GRADE E-70.
7. ALL BOLTS AND WASHERS SHALL BE GALVANIZED STEEL OR STAINLESS STEEL WITH A MINIMUM TENSILE STRENGTH OF 60 KSI.
8. DOORS SHALL BE PROVIDED WITH A SINGLE CURTAIN MOUNTED SLIDE LOCK LATCH THAT ENGAGES THE DOOR GUIDE WHEN DOOR IS FULLY CLOSED.
9. DOOR ASSEMBLY DESIGN BASED ON ELEMENT MATERIALS TECHNOLOGY, TEST REPORT NO. ESP013417P
10. ANCHOR NOTES:
A. EMBEDMENT LENGTH DOES NOT INCLUDE STUCCO FINISH.
B. FOR HOLLOW MASONRY BLOCK, FILL ALL CELLS AT ANCHOR LOCATIONS WITH MINIMUM 2000 PSI GROUT.
C. CONCRETE JAMBS TO BE MINIMUM 2500 PSI.
D. ANCHORS SHALL BE INSTALLED IN ACCORDANCE WITH MANUFACTURER'S SPECIFICATIONS.
E. ALTERNATE FASTENER: HILTI HUS-EZ 3/8" X 4" @ 4" FROM FLOOR AND 8-1/2" O.C. MAX W/MIN EMBEDMENT OF 3-1/2" IN BOTH FILLED CONCRETE BLOCK AND CONCRETE.
11. GUIDE TO JAMB ATTACHMENT FASTENERS BEGIN 4" FROM FLOOR AND END 3/4" BELOW TOP OF WALL OPENING.
12. TEST DOOR WALL OPENING SIZE: 8'-8" X 8'-0".

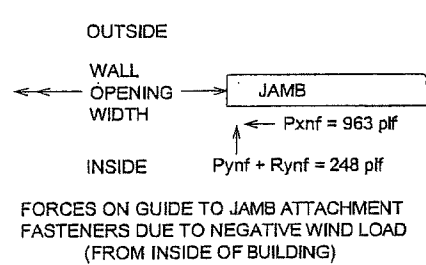
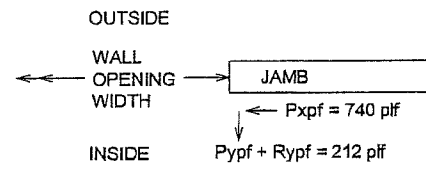

STEEL JAMBS

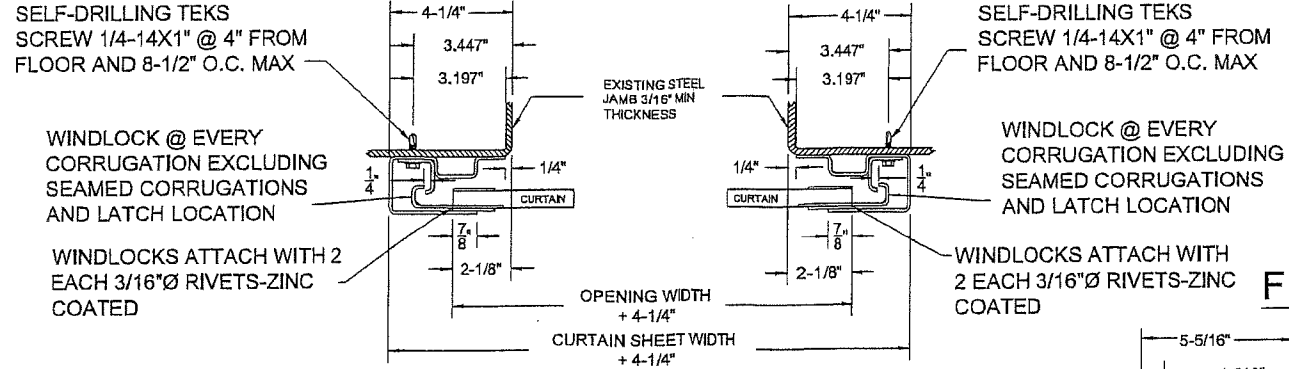

PRODUCT RENEWED
as complying with the Florida Building Code
NOA-No. **18-1011.02**
Expiration Date **02/26/2024**
By *[Signature]*
Miami-Dade Product Control

FILLED BLOCK JAMBS

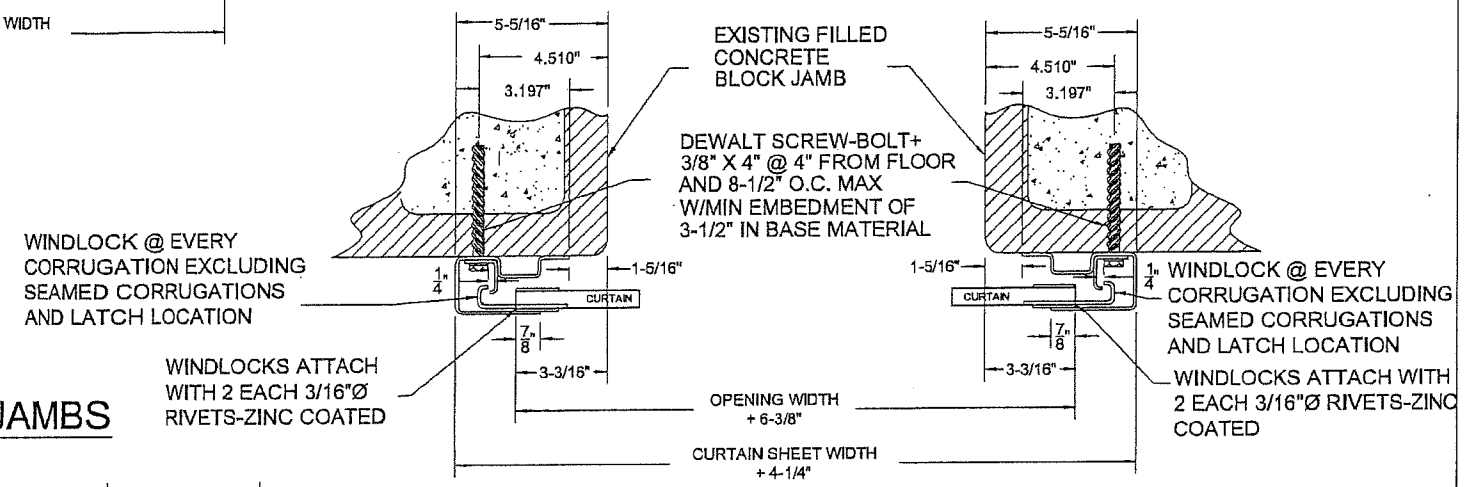

PRODUCT REVISED
as complying with the Florida Building Code
NOA-No. **18-0118.02**
Expiration Date **02/26/2019**
By *[Signature]*
Miami-Dade Product Control

CONCRETE JAMBS

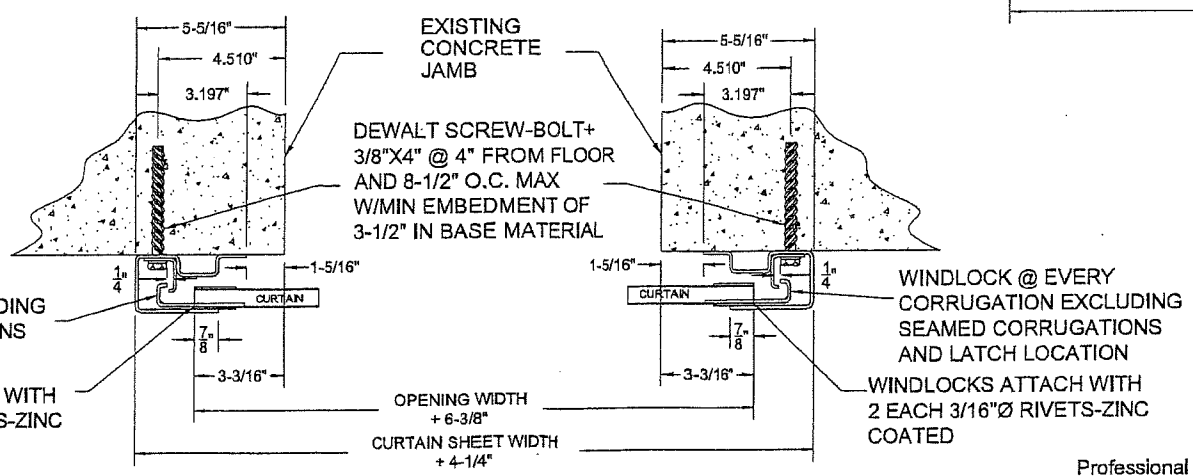

Professional Engineer's seal provided only for verification of windload construction details.

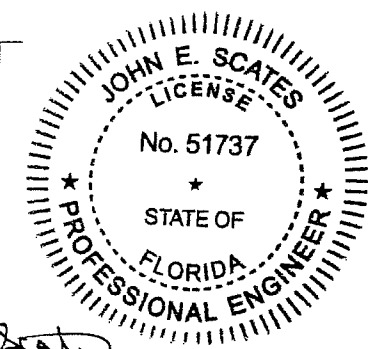

John E. Scates, P.E.
2560 King Arthur Blvd.
Lewisville, TX 75058
FL PE 51737

John E. Scates
3/9/18

UNLESS OTHERWISE SPECIFIED DIMENSIONS ARE IN INCHES AND TOLERANCES ARE:

| DECIMAL | FRACTIONS | ANGLES | HOLE DIAMETERS |
|--------------|-----------|----------|-------------------------------|
| .XX ± 0.03 | ± 1/16 | ± 0° 30' | UNDER .251 +.004 -.003 |
| .XXX ± 0.005 | | | 0.251 to 0.500 +.006 -.003 |
| | | | OVER 0.500 +.008 -.003 |

| | | | |
|------------------------|--|----------------------------------|---------------------------------|
| PART NUMBER: NA | JANUS INTERNATIONAL GROUP, LLC | | |
| MATERIAL: NA | 135 JANUS INTERNATIONAL BLVD. TEMPLE, GA 30179-4435 | | |
| APPLIED FINISH: NA | 770-562-2850/Fax 770-562-2264 | | |
| UNIT OF MEASURE: NA | © 2018 Janus International Group, LLC. All Rights Reserved | | |
| APPROVALS | DATE | DADE COUNTY MINI DOOR SERIES 850 | |
| DRAWN: BECKY NELSON | 7-25-03 | MAX. SIZE 8'-8" X 12'-0" | |
| CHECKED: DON MILLS | 9-15-03 | SIZE B | DRAWING NUMBER: T1006 |
| APPROVED: DON MILLS | 9-15-03 | SCALE: NONE | REV: D |
| | | SHEET: 2 | OF: 2 |

REVISIONS

| REV | DESCRIPTION | DATE | APPROVAL |
|-----|----------------------------|---------|----------|
| — | DRAWING RELEASE | 9-15-03 | DM |
| A | DADE COUNTY CHANGES | 1-16-04 | DM |
| B | GDE FAS SPA 10"-8.5" | 6-10-05 | DM |
| C | RETEST 8-5-2013 | 8-26-13 | CS |
| D | CO. NAME & FASTENER CHANGE | 6-5-17 | CS |



DEPARTMENT OF REGULATORY AND ECONOMIC RESOURCES (RER)
 BOARD AND CODE ADMINISTRATION DIVISION
NOTICE OF ACCEPTANCE (NOA)

MIAMI-DADE COUNTY
 PRODUCT CONTROL SECTION
 11805 SW 26 Street, Room 208
 Miami, Florida 33175-2474
 T (786) 315-2590 F (786) 315-2599
www.miamidade.gov/economy

Janus International Group, LLC
135 Janus International Blvd.
Temple, GA 30179

SCOPE:

This NOA is being issued under the applicable rules and regulations governing the use of construction materials. The documentation submitted has been reviewed and accepted by Miami-Dade County RER-Product Control Section to be used in Miami Dade County and other areas where allowed by the Authority Having Jurisdiction (AHJ).

This NOA shall not be valid after the expiration date stated below. The Miami-Dade County Product Control Section (In Miami Dade County) and/or the AHJ (in areas other than Miami Dade County) reserve the right to have this product or material tested for quality assurance purposes. If this product or material fails to perform in the accepted manner, the manufacturer will incur the expense of such testing and the AHJ may immediately revoke, modify, or suspend the use of such product or material within their jurisdiction. RER reserves the right to revoke this acceptance, if it is determined by Miami-Dade County Product Control Section that this product or material fails to meet the requirements of the applicable building code.

This product is approved as described herein, and has been designed to comply with the Florida Building Code, including the High Velocity Hurricane Zone.

DESCRIPTION: Series 850 Steel Roll-up Door up to 8'-8" Wide

APPROVAL DOCUMENT: Drawing No. **T1006**, titled "Dade County Mini Door Series 850 Max. Size 8'-8" x 12'-0", sheets 1 and 2 of 2, dated 09/15/2003, with last revision D dated 06/05/2017, prepared by Janus International Corporation, signed and sealed by John E. Scates, P.E., bearing the Miami-Dade County Product Control renewal stamp with the Notice of Acceptance number and expiration date by the Miami-Dade County Product Control Section.

MISSILE IMPACT RATING: Large and Small Missile Impact Resistant

LABELING: A permanent label with the manufacturer's name or logo, manufacturing address, model/series number, the positive and negative design pressure rating, indicate impact rated if applicable, installation instruction drawing reference number, approval number (NOA), the applicable test standards, and the statement reading 'Miami-Dade County Product Control Approved' is to be located on the door's side track, bottom angle, or inner surface of a panel.

RENEWAL of this NOA shall be considered after a renewal application has been filed and there has been no change in the applicable building code negatively affecting the performance of this product.

TERMINATION of this NOA will occur after the expiration date or if there has been a revision or change in the materials, use, and/or manufacture of the product or process. Misuse of this NOA as an endorsement of any product, for sales, advertising or any other purposes shall automatically terminate this NOA. Failure to comply with any section of this NOA shall be cause for termination and removal of NOA.

ADVERTISEMENT: The NOA number preceded by the words Miami-Dade County, Florida, and followed by the expiration date may be displayed in advertising literature. If any portion of the NOA is displayed, then it shall be done in its entirety.

INSPECTION: A copy of this entire NOA shall be provided to the user by the manufacturer or its distributors and shall be available for inspection at the job site at the request of the Building Official.

This NOA **renews NOA #18-0118.02** and consists of this page 1 and evidence pages E-1 and E-2, as well as approval document mentioned above.

The submitted documentation was reviewed by **Carlos M. Utrera, P.E.**



[Handwritten Signature]
 11/20/2018

NOA No. 18-1011.02
Expiration Date: February 26, 2024
Approval Date: November 29, 2018
 Page 1

NOTICE OF ACCEPTANCE: EVIDENCE SUBMITTED

1. Submitted under previous NOAs

A. DRAWINGS “Submitted under NOA # 15-0312.01”

1. Drawing No. **T1006**, titled “Dade County Mini Door Series 850 Max. Size 8’-8” x 12’-0””, sheets 1 and 2 of 2, dated 09/15/2003, with last revision C dated 08/26/2013, prepared by Janus International Corporation, signed and sealed by Joseph H. Dixon, Jr., P.E.

B. TESTS “Submitted under NOA # 13-1203.05”

1. Test reports on 1) Uniform Static Air Pressure Test, Loading per FBC TAS 202-94
2) Large Missile Impact Test per FBC, TAS 201-94
3) Cyclic Wind Pressure Loading per FBC, TAS 203-94
4) Forced Entry Resistance Test per FBC, TAS 202-94
along with marked-up drawings and installation diagram of a Series 850, 8’-8” wide x 8’-0” high, 26 ga steel garage door, prepared by Element Materials Technology, Test Report No. **ESP013417P**, dated 08/26/2013, signed and sealed by Ramesh C. Patel, P.E.
“Submitted under NOA # 03-0929.05”
2. Test report on Large Missile Impact Test per TAS 201, Cyclic Wind Pressure Test per TAS 203 and Uniform Static Air Pressure Test per TAS 202 on Specimens 1, 2, 3 & 4 Door 8’-8” wide, 8’-0” high, prepared by Certified Testing Laboratories, Test Report No. **CTLA 1115W**, dated 08/20/2003, signed and sealed by R. Patel, P.E.

C. CALCULATIONS “Submitted under NOA # 05-0623.04”

1. Revised anchorage calculations prepared by Joseph H. Dixon Jr., P.E., dated 05/27/2005, sheets 1 through 11, signed and sealed by J. H. Dixon Jr., P.E.
2. Calculations for attachment of guide to steel, concrete or masonry jamb, prepared by Joseph H. Dixon, Jr., P.E., dated 06/29/2003, sheets 1 to 11, signed and sealed by Joseph H. Dixon, Jr., P.E. “Submitted under NOA # 03-0929.05”

D. QUALITY ASSURANCE

1. Miami-Dade Department of Regulatory and Economic Resources (RER)

E. MATERIAL CERTIFICATIONS “Submitted under NOA # 03-0929.05”

1. Tensile test report per ASTM E8/A370 or B557, prepared by Certified Testing Laboratories, Test Report No. **1115W**, dated 07/22/2003, signed by R. Patel, P.E.

F. STATEMENTS “Submitted under NOA # 15-0312.01”

1. Statement letter of code conformance to the 5th edition (2014) FBC, dated 03/04/2015, issued, signed and sealed by Joseph H. Dixon, Jr., P.E.
“Submitted under NOA # 12-0326.01”
2. Statement letter of code conformance to 2010 FBC, dated 03/14/2012, signed and sealed by Joseph H. Dixon, Jr., P.E.
3. Statement letter of no financial interest, dated 09/22/2003, signed and sealed by Joseph H. Dixon, Jr., P.E.

11/20/2018

Carlos M. Utrera, P.E.
Product Control Examiner
NOA No. 18-1011.02
Expiration Date: February 26, 2024
Approval Date: November 29, 2018

NOTICE OF ACCEPTANCE: EVIDENCE SUBMITTED

2. Evidence submitted under NOA # 18-0118.02

A. DRAWINGS

1. Drawing No. **T1006**, titled "Dade County Mini Door Series 850 Max. Size 8'-8" x 12'-0", sheets 1 and 2 of 2, dated 09/15/2003, with last revision D dated 06/05/2017, prepared by Janus International Corporation, signed and sealed by John E. Scates, P.E.

B. TESTS

1. None.

C. CALCULATIONS

1. Anchorage and structural calculations prepared by John E. Scates, P.E., dated 12/30/2017, signed and sealed by John E. Scates, P.E.

D. QUALITY ASSURANCE

1. Miami-Dade Department of Regulatory and Economic Resources (RER)

E. MATERIAL CERTIFICATIONS

1. None.

F. STATEMENTS

1. Statement letter of code conformance to the 6th edition (2017) FBC issued by John E. Scates, P.E., dated 02/06/2018, signed and sealed by John E. Scates, P.E.
2. Statement letter of no financial interest issued by John E. Scates, P.E., dated 12/30/2017, signed and sealed by John E. Scates, P.E.
3. Certificate of Merger dated 12/12/2013.



11/20/2018

Carlos M. Utrera, P.E.
Product Control Examiner
NOA No. 18-1011.02
Expiration Date: February 26, 2024
Approval Date: November 29, 2018