

CURTAIN PANEL
 ASTM A653 GR80 - ZINC COATED STEEL
 PRE-PAINTED WITH FULL COAT OF PRIMER AND
 BAKED SILICONIZED POLYESTER FINISH COAT
 26 GA CURTAIN DETAIL

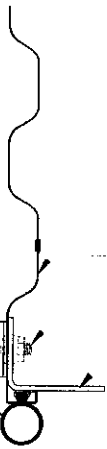

24 GA. (0.022") GALV. STEEL BOTTOM BAR
 ASTM A653 W/MIN. FY = 33 KSI

DOUBLE 1/4" Ø THRU BOLT WITH LOCKING NUT LOCATED AT EACH END AND MIDDLE OF ANGLE. INTERMEDIATE SINGLE BOLT LOCATED 24" MAX O.C.

2" X 1-1/2" X 0.105" GALV. STEEL ANGLE
 ASTM A653 W/MIN. FY = 33 KSI
 CONTINUOUS FULL CURTAIN WIDTH

REVISIONS			
REV	DESCRIPTION	DATE	APPROVAL
---	DRAWING RELEASE	11-14-02	DM
A	NOTE REVISIONS	4-16-04	DM
B	NOTE REVISIONS	6-17-08	CS
C	RE-TEST 9-26-13	10-24-13	CS

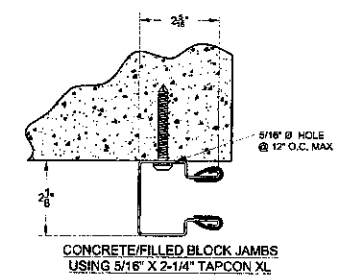

ALL COMPONENTS SHALL BE ASTM A653 STEEL W/MIN FY = 33 KSI. GALVANIZED PER ASTM A653 G90

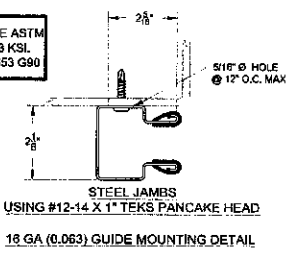

OPENING HEIGHT	VERTICAL HEADROOM	HORIZONTAL HEADROOM
THRU 7'-4"	15-1/2"	17-1/2"
OVER 7'-4" THRU 8'-8"	16"	18"
OVER 8'-8" THRU 10'-0"	17"	18-1/4"

HEADROOM REQUIRED

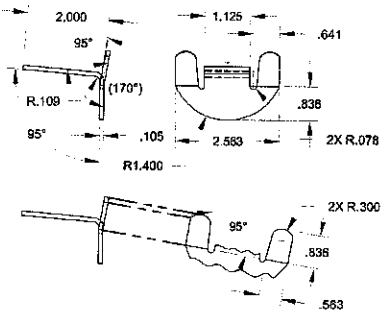

WINDLOCK
 GALV. STEEL
 ASTM A653
 WITH MIN.
 FY=33KSI

THESE CONFIDENTIAL DOCUMENTS SUBMITTED BY JANUS CONTAIN INFORMATION OF A PROPRIETARY NATURE AND MAY NOT BE REPRODUCED OR USED TO MANUFACTURE ANYTHING IN PART OR IN WHOLE FOR ANY PURPOSE OTHER THAN THAT WHICH IS NECESSARY FOR PREPARATION OF BIDS OF ENGINEERING WITHOUT THE EXPRESS PERMISSION OF JANUS WHICH MAY RECALL DOCUMENTS AT ANY TIME.

UNLESS OTHERWISE SPECIFIED DIMENSIONS ARE IN INCHES AND TOLERANCES ARE:

DECIMAL	FRACTIONS	ANGLES	HOLE DIAMETERS
	± 1/16	± 0° 30'	UNDER 0.251 +.004 -.003
			0.251 to 0.500 +.008 -.003
			OVER 0.500 +.008 -.003

PART NUMBER:	
MATERIAL:	
APPLIED FINISH:	
UNIT OF MEASURE:	
APPROVALS	DATE
DRAWN: BECKY NELSON	11-14-02
CHECKED: DON MILLS	11-14-02
APPROVED: DON MILLS	11-14-02

JANUS INTERNATIONAL CORPORATION
 135 JANUS INTERNATIONAL BLVD. TEMPLE, GA 30179-4435
 770-562-2850/Fax 770-562-2264
 © 2013 Janus International Corporation All Rights Reserved

CERTIFIED WIND LOAD RATED
 26 GA SERIES 750 DOOR ASSEMBLY
 MAX. SIZE: 8'-8" X 12'-0"

SIZE	DRAWING NUMBER	REV.
B	T1002	C

SCALE: NONE SHEET: 1 OF 2

STATE OF TEXAS
 JOSEPH H. DIXON, JR.
 18627
 LICENSED PROFESSIONAL ENGINEER
 12/11/13

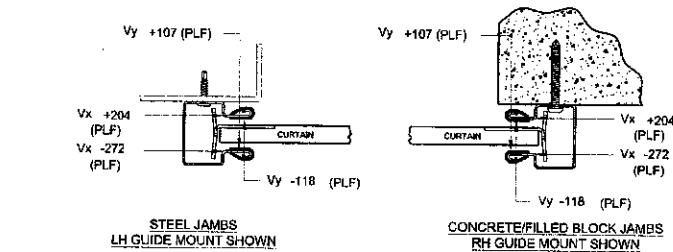
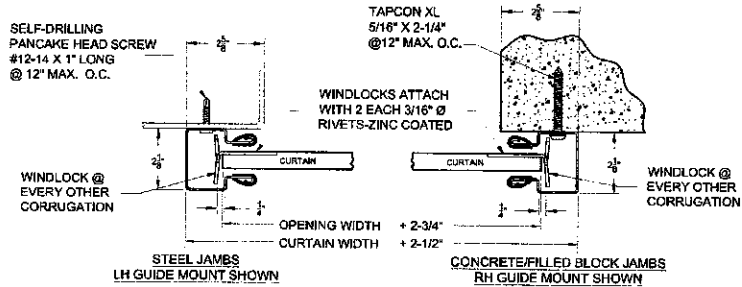

SUPERIMPOSED LOAD DIAGRAM

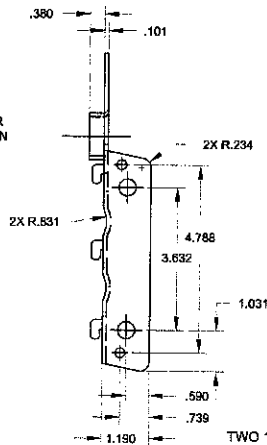

REAR VIEW

EXISTING CONCRETE

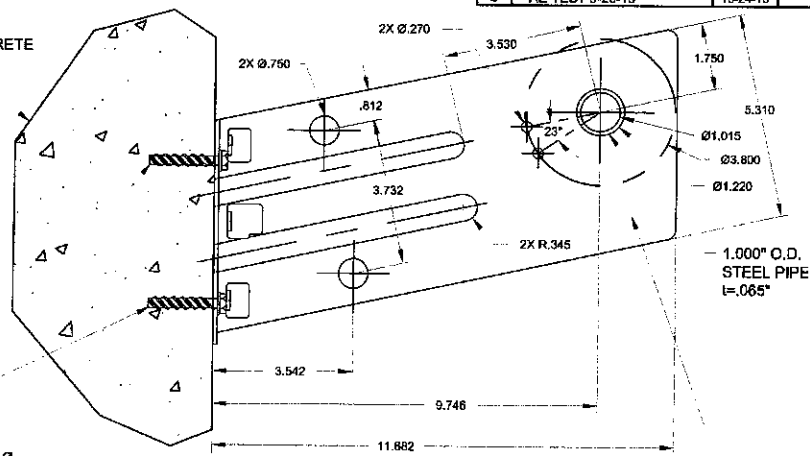

SIDE VIEW

TWO 1/4\"/>

ASTM A653 WITH Fy = 37 KSI GALV. STEEL IN ACCORDANCE WITH ASTM A653 G90

DOOR MOUNTING BRACKET DETAIL

REVISIONS			
REV	DESCRIPTION	DATE	APPROVAL
	DRAWING RELEASE	11-14-02	DM
A	NOTE REVISIONS	4-16-04	DM
B	NOTE REVISIONS	8-17-08	CS
C	RE-TEST 9-26-13	10-24-13	CS

GENERAL NOTES

- THIS ROLL-UP DOOR SYSTEM IS DESIGNED IN ACCORDANCE WITH THE FLORIDA BUILDING CODE.
- THIS ROLL-UP DOOR HAS BEEN TESTED IN ACCORDANCE WITH ASTM E-330 AND COMPLIES WITH ANSIDASMA 108.
DESIGN LOAD = +24.4 PSF
-27.0
- WIND LOADS FOR BUILDING OPENINGS SHALL BE DETERMINED BY A PROFESSIONAL ENGINEER USING APPROPRIATE WIND SPEED AND DESIGN CRITERIA. THIS DOOR MAY BE USED WHERE THE DESIGN LOAD MEETS OR EXCEEDS THE DESIGN LOAD FOR THE BUILDING OPENING.
- SUPERIMPOSED LOADS ON THE JAMBS FROM THIS DOOR ARE DESIGNED AS Vx AND Vy HEREIN. CONTRACTORS SHALL HAVE BUILDING ENGINEER VERIFY ADEQUACY OF BUILDING STRUCTURE TO RESIST SUPERIMPOSED LOADS Vx, Vy, AND BRACKET LOADS SHOWN.
- ALL WELDING SHALL BE PERFORMED BY QUALIFIED WELDERS IN ACCORDANCE WITH A.W.S. SPECIFICATIONS, LATEST EDITION. ALL WELDING ELECTRODES SHALL CONFORM TO A.W.S. A5.1 GRADE E-70.
- DOORS SHALL BE PROVIDED WITH LOCK MECHANISMS AT THE OPTION OF THE OWNER.
- ALL BOLTS AND WASHERS SHALL BE GALVANIZED OR STAINLESS STEEL WITH A MINIMUM TENSILE STRENGTH OF 60 KSI.
- DESIGN BASED ON ELEMENT MATERIALS TECHNOLOGY TEST REPORT NO. ESP014073P-2.

- ANCHOR NOTES:
A. EMBEDMENT LENGTH DOES NOT INCLUDE STUCCO FINISH.
B. FOR HOLLOW MASONRY, FILL ALL CELLS @ ANCHOR WITH 2500 PSI GROUT.
C. ANCHORS SHALL BE INSTALLED IN ACCORDANCE WITH MANUFACTURER'S SPECIFICATIONS.

- DOOR OPERATION TYPED TO BE PUSH-UP.
- GUIDE TO JAMB ATTACHMENT FASTENERS BEGIN 4\"/>
- TEST DOOR WALL OPENING SIZE: 8'-8\"/>

THESE CONFIDENTIAL DOCUMENTS SUBMITTED BY JANUS CONTAIN INFORMATION OF A PROPRIETARY NATURE AND MAY NOT BE REPRODUCED OR USED TO MANUFACTURE ANYTHING IN PART OR IN WHOLE FOR ANY PURPOSE OTHER THAN THAT WHICH IS NECESSARY FOR PREPARATION OF BIDS OF ENGINEERING WITHOUT THE EXPRESS PERMISSION OF JANUS WHICH MAY RECALL DOCUMENTS AT ANY TIME.

UNLESS OTHERWISE SPECIFIED DIMENSIONS ARE IN INCHES AND TOLERANCES ARE:

DECIMAL	FRACTIONS	ANGLES	HOLE DIAMETERS
	± 1/16	± 0° 30'	UNDER 0.251 +.004 -.003
			0.251 to 0.500 +.006 -.003
			OVER 0.500 +.008 -.003

PART NUMBER:	
MATERIAL:	
APPLIED FINISH:	
UNIT OF MEASURE:	
APPROVALS	DATE
DRAWN: BECKY NELSON	11-14-02
CHECKED: DON MILLS	11-14-02
APPROVED: DON MILLS	11-14-02

JANUS INTERNATIONAL CORPORATION
 135 JANUS INTERNATIONAL BLVD. TEMPLE, GA 30179-4435
 770-562-2850/Fax 770-562-2264
 © 2013 Janus International Corporation All Rights Reserved

CERTIFIED WIND LOAD RATED
 26 GA SERIES 750 DOOR ASSEMBLY
 MAX. SIZE: 8'-8\"/>

SIZE B	DRAWING NUMBER: T1002	REV: C
SCALE: NONE	SHEET: 2	OF: 2

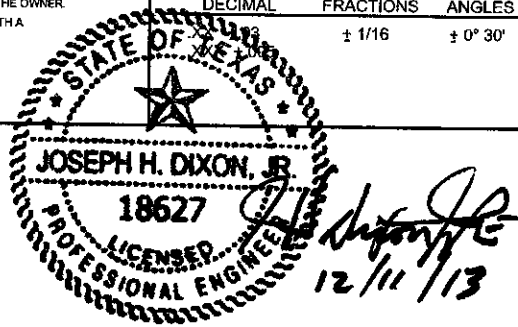



Product Evaluation

GDR39 | 0318

Engineering Services Program

The following product has been evaluated for compliance with the wind loads specified in the International Residential Code (IRC) and the International Building Code (IBC).

This product evaluation is not an endorsement of this product or a recommendation that this product be used. The Texas Department of Insurance has not authorized the use of any information contained in the product evaluation for advertising, or other commercial or promotional purpose.

This product evaluation is intended for use by those individuals who are following the design wind load criteria in Chapter 3 of the IRC and Section 1609 of the IBC. The design loads determined for the building or structure shall not exceed the design load rating specified for the products shown in the limitations section of this product evaluation. This product evaluation does not relieve a Texas licensed engineer of his responsibilities as outlined in the Texas Insurance Code, the Texas Administrative Code, and the Texas Engineering Practice Act.

For more information, contact TDI Engineering Services Program at (800) 248-6032.

Evaluation ID: GDR-39

Effective Date: March 1, 2018

Re-evaluation Date: March 2022

Product Name: Series 750 Steel Roll Up Doors, Non-impact Resistant

Manufacturer: Janus International Corporation
135 Janus International Blvd.
Temple, GA 30179-4435
(866) 562-2580
www.janusintl.com

General Description:

This evaluation report is for the Series 750 steel roll up doors. The steel roll-up doors consist of a corrugated steel curtain that is suspended from a barrel. Coil springs, located within the barrel, raise and lower the curtain, which wraps around the barrel. A push-up, hand chain, or electric operation raise the steel curtain. The sides of the curtain are constrained from lateral movement along their vertical edges by steel guides that are attached to the structure. The steel roll up doors specified in this evaluation report are non-impact resistant. This evaluation report includes the following doors:

System	Description	Maximum Width	Maximum Height
1	26-Gauge Series 750 Roll Up Doors; Single Curtain	3'-0"	12'-0"
2	26-Gauge Series 750 Roll Up Doors; Single Curtain	6'-0"	12'-0"
3	26-Gauge Series 750 Roll Up Doors; Single Curtain; Windlocks	8'-8"	12'-0"
4	26-Gauge Series 750 Roll Up Doors; Single Curtain; Windlocks	10'-0"	12'-0"

The steel roll up doors specified in this evaluation report consist of the following components:

- **Curtain:** 26-gauge corrugated steel that is roll-formed from ASTM A 653 grade 80 steel. The corrugated sheets are galvanized and pre-painted with silicone polyester paint. The corrugated sheets are interlocked mechanically to form the curtain.
- **Guides (Systems 1 and 2):** 18-gauge roll-formed from ASTM A 653 steel. The dimensions of the guide are 1-31/32" x 1-19/32".
- **Guides (Systems 3 and 4):** 16-gauge roll-formed from ASTM A 653 steel. The dimensions of the guide are 2-1/8" x 2-5/16".
- **Bottom Bar (Systems 1 and 2):** One 24-gauge galvanized steel bottom bar full length of curtain. One roll-formed steel angle, 2" x 1-1/2" x 0.105" x full length. The steel angle is attached to the steel bottom bar with 1/4" diameter thru bolts and lock nuts. One bolt is located at each end and two bolts are located at the center. A continuous vinyl bulb astragal is attached to the bottom of the steel angle.
- **Bottom Bar (Systems 3 and 4):** One 24-gauge galvanized steel bottom bar full length of curtain. One roll-formed steel angle, 2" x 1-1/2" x 0.105" x full length. The steel angle is attached to the steel bottom bar with 1/4" diameter thru bolts and lock nuts. Two bolts are located at each end and two bolts are located at the center. One bolt is located 24" on center. A continuous vinyl bulb astragal is attached to the bottom of the steel angle.
- **Windlocks (Systems 3 and 4):** 12-gauge galvanized steel. The windlock is attached to each side of the curtain at every other corrugation. Each windlock is attached to the curtain with two, 3/16" diameter zinc coated rivets.
- **Hardware:** Slide latch

Product Identification: A label will be affixed to the bottom bar of the steel roll up door. The label shall include the manufacturer's name, series number of door, the allowable design pressure rating, the design drawing number, and tested per ASTM E 330 and ANSI/DASMA 108.

Limitations:

System	Maximum Width	Maximum Height	Drawing	Design Pressure Rating (psf)
1	3'-0"	12'-0"	T1000 (See note below)	+35, -45
2	6'-0"	12'-0"	T1001 (See note below)	+19.9, -24.4
3	8'-8"	12'-0"	T1002 (See note below)	+24.4, -27
4	10'-0"	12'-0"	T1003 (See note below)	+19.4, -22.7

- **Glazing:** None
- **Impact Resistance:** The doors listed in this report do not satisfy TDI's criteria for protection from windborne debris. Protect the door assemblies with an impact protective system when installing the product in areas that require windborne debris protection.
- **Acceptance of Smaller Assemblies:** Door assemblies with dimensions equal to or smaller than those specified above are acceptable within the limitations specified in this report.
- **Drawings** (The appropriate drawing listed below must be available at the job site):
 - **System 1:** Janus International Corporation; Certified Wind Load Rated 26 GA. Series 750 Door Assembly Max. Size 3'-0" x 12'-0"; Drawing No. T1000, Rev C; Sheet 1 and 2 of 2; revised 10-24-13; sealed by Joseph H. Dixon, P.E., dated December 11, 2013.

- **System 2:** Janus International Corporation; Certified Wind Load Rated 26 GA. Series 750 Door Assembly Max. Size 6'-0" x 12'-0"; Drawing No. T1001, Rev C; Sheet 1 and 2 of 2; revised 10-24-13; sealed by Joseph H. Dixon, P.E., December 11, 2013.
- **System 3:** Janus International Corporation; Certified Wind Load Rated 26 GA. Series 750 Door Assembly Max. Size 8'-8" x 12'-0"; Drawing No. T1002, Rev C; Sheet 1 and 2 of 2; revised 10-24-13; sealed by Joseph H. Dixon, P.E., dated December 11, 2013.
- **System 4:** Janus International Corporation; Certified Wind Load Rated 26 GA. Series 750 Door Assembly Max. Size 10'-0" x 12'-0"; Drawing No. T1003, Rev A; Sheet 1 and 2 of 2; revised 4-16-2004; sealed by Joseph H. Dixon, P.E., dated December 11, 2013.

Installation Instructions:

Install the steel roll up doors to the substrate using one of the following methods (refer to the design drawings referenced above for further guidance):

Bolted to cast-in-place, pre-cast concrete, or grout-filled CMU substrate:

- **Systems 1 and 2: Guide Mounting:** Anchor each guide to the substrate with minimum 1/4" x 1-3/4" Powers Wedge-Bolt anchors. Place the anchors through the interior of the guide into the substrate. Space the anchors a maximum of 24" on center along the length of the guide through the pre-drilled holes in the guide. If the bolt must penetrate through a wall covering, then increase the bolt length by the thickness of the wall covering material. Locate the back end of the guide a minimum of 1-31/32" away from the edge of the door opening. Grout must be minimum 2,500 psi. **Tensioner Bracket Mounting:** Anchor each bracket to the substrate with two minimum 1/4" diameter Powers Wedge-Bolt anchors with a minimum 1-1/2" embedment. If the bolts must penetrate through a wall covering, then increase the bolt length by the thickness of the wall covering material.
- **Systems 3 and 4: Guide Mounting:** Anchor each guide to the substrate with minimum 5/16" x 2-1/4" Tapcon XL anchors. Place the anchors through the interior of the guide into the substrate. Space the anchors a maximum of 12" on center along the length of the guide through the pre-drilled holes in the guide. If the bolt must penetrate through a wall covering, then increase the bolt length by the thickness of the wall covering material. Locate the back end of the guide a minimum of 2-5/8" away from the edge of the door opening. Grout must be minimum 2,500 psi. **Tensioner Bracket Mounting:** Anchor each bracket to the substrate with two minimum 1/4" diameter Powers Wedge-Bolt anchors with a minimum 1-1/2" embedment. If the bolts must penetrate through a wall covering, then increase the bolt length by the thickness of the wall covering material.

Bolted to steel substrate:

- **Systems 1 and 2: Guide Mounting:** The steel substrate shall be minimum 1/8" thick A36 steel. Anchor each guide to the substrate with minimum 1/4-14 x 1" self-drilling TEKS screws. Place the screws through the interior of the guide into the substrate. Space the screws a maximum of 24" on center along the length of the guide through the pre-drilled holes in the guide. If the screws must penetrate through a wall covering, then increase the bolt length by the thickness of the wall covering material. **Tensioner Bracket Mounting:** Anchor each bracket to the substrate with two minimum 1/4" diameter steel screws with full penetration into the steel. If the screws must penetrate through a wall covering, then increase the screw length by the thickness of the wall covering material.

- **Systems 3 and 4: Guide Mounting:** The steel substrate shall be minimum 1/8" thick A36 steel. Anchor each guide to the substrate with minimum #12-14 x 1" self-drilling TEKS screws. Place the screws through the interior of the guide into the substrate. Space the screws a maximum of 12" on center along the length of the guide through the pre-drilled holes in the guide. If the screws must penetrate through a wall covering, then increase the bolt length by the thickness of the wall covering material. **Tensioner Bracket Mounting:** Anchor each bracket to the substrate with two minimum 1/4" diameter steel screws with full penetration into the steel. If the screws must penetrate through a wall covering, then increase the screw length by the thickness of the wall covering material.

Note: Keep the manufacturer's installation instructions available on the job site during installation. Use corrosion resistant fasteners as specified in the IRC, the IBC, and the Texas Revisions.