

Joseph H. Dixon, Jr.
12/4/12

REVISIONS			
REV	DESCRIPTION	DATE	APPROVAL
—	DRAWING RELEASE	9-15-03	DM
A	GENERAL CHANGES	1-16-04	DM
B	NOTE REVISION	6-17-09	CS

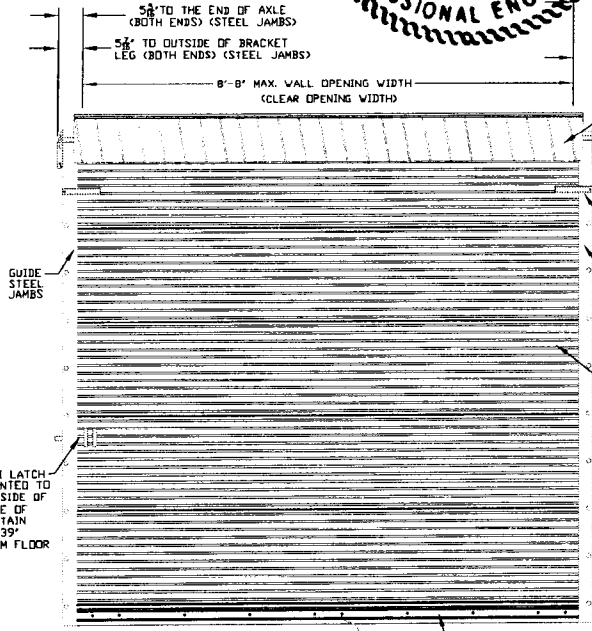

6\"/>

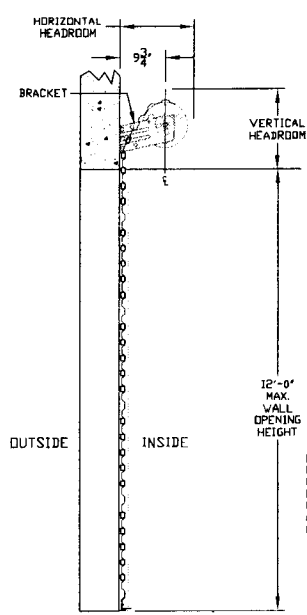
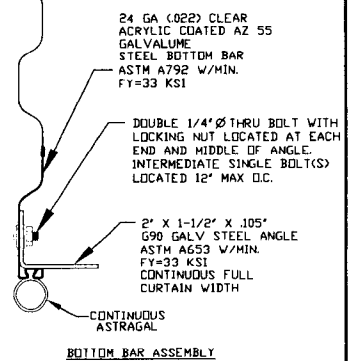
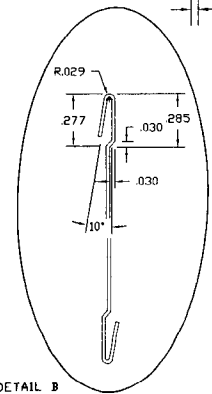
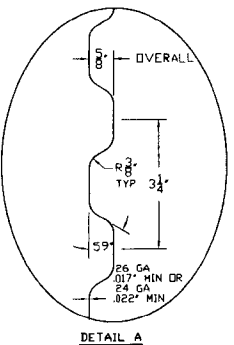
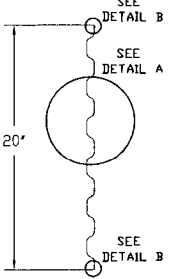
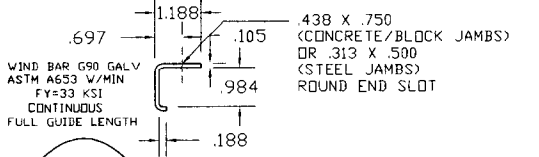
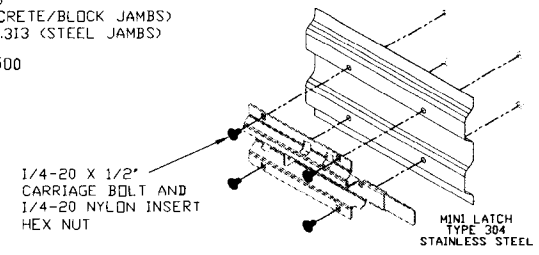
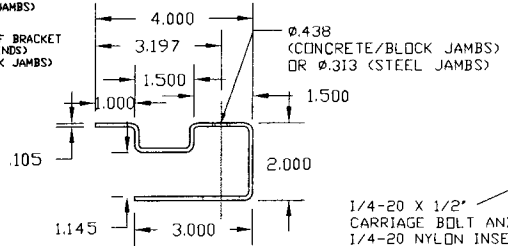

HEADROOM REQUIRED		
OPENING HEIGHT	VERTICAL HEADROOM	HORIZONTAL HEADROOM
THRU 7'-4"	15-1/2"	17-1/2"
OVER 7'-4" THRU 8'-8"	16"	18"
OVER 8'-8" THRU 10'-0"	17"	18-1/4"

ASTM A653 GR 80 MIN FY=80 KSI. G90 GALVANIZED STEEL DR G60 GALVANIZED STEEL WITH PRE-PAINTED SILICONE POLYESTER PAINT ON BOTH SIDES OF CURTAIN.

CURTAIN PANELS LOCK SEAMED TOGETHER.
CURTAIN DETAIL

STRUCTURAL ENGINEER: JOSEPH H. DIXON, JR. P.E. FL #7768

UNLESS OTHERWISE SPECIFIED DIMENSIONS ARE IN INCHES AND TOLERANCES ARE:

DECIMAL	FRACTIONS	ANGLES	HOLE DIAMETERS
.XX ±.03	± 1/16	± 0° 30'	UNDER .251 +.004 -.003
.XXX ±.005			.251 to .500 +.006 -.003
			OVER .500 +.008 -.003

PART NUMBER: NA	
MATERIAL: NA	
APPLIED FINISH: NA	
UNIT OF MEASURE: NA	
APPROVALS	DATE
DRAWN: BECKY NELSON	7-25-03
CHECKED: DON MILLS	9-15-03
APPROVED: DON MILLS	9-15-03

JANUS INTERNATIONAL CORPORATION
134 JANUS INTERNATIONAL BLVD TEMPLE, GA 30179
770-562-2850/Fax 770-562-2264
© 2012 Janus International Corporation All Rights Reserved

FLORIDA STATE MINI DOOR SERIES 850-S
MAX. SIZE 8'-8" X 12'-0"

SIZE: B	DRAWING NUMBER: T1006-S	REV: B
SCALE: NONE	SHEET: 1 OF 2	

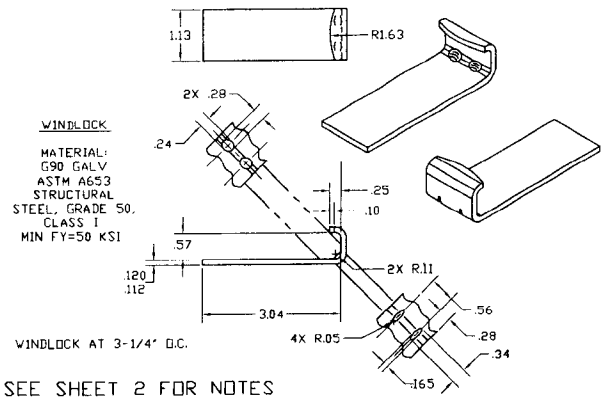

SEE SHEET 2 FOR NOTES

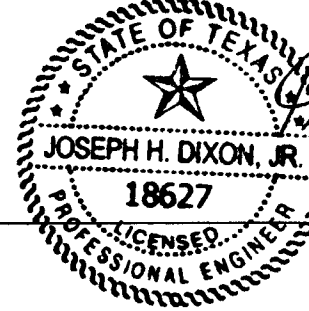

Signature
12/4/12

REVISIONS			
REV	DESCRIPTION	DATE	APPROVAL
—	DRAWING RELEASE	9-15-03	DM
A	GENERAL CHANGES	1-16-04	DM
B	NOTE REVISION	6-17-09	CS

STEEL JAMBS

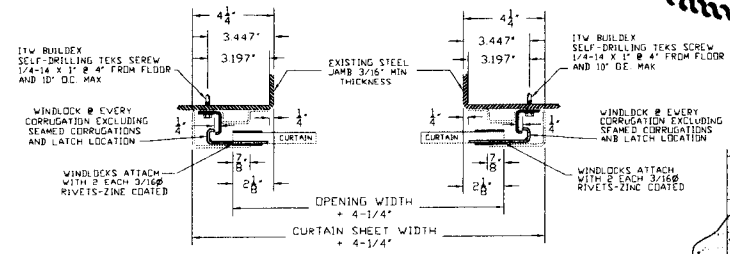

FILLED BLOCK JAMBS

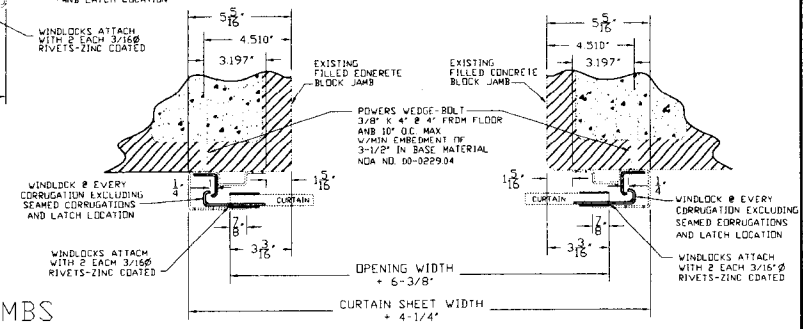

CONCRETE JAMBS

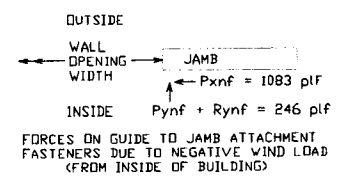
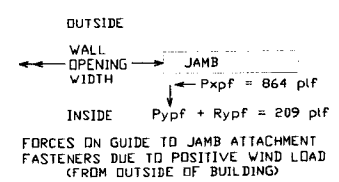
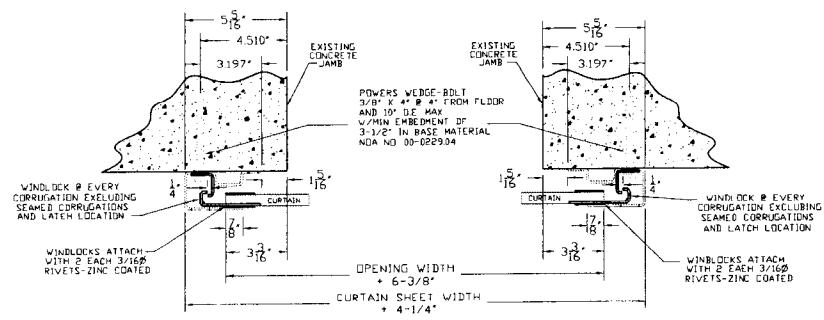

GENERAL NOTES

- THIS ROLL-UP DOOR SYSTEM HAS BEEN SUCCESSFULLY TESTED ACCORDING TO THE UNIFORM STATIC AIR PRESSURE TEST PER TAS 202-94, THE LARGE MISSILE IMPACT TEST PER TAS 201-94 AND THE CYCLIC WIND PRESSURE LOADING TEST PER TAS 203-94. IN AN INDEPENDENT TESTING LAB CONFORMING TO TAS 301-94. CURTAIN MATERIAL THICKNESS OF .017" (26 GA) AND .022" (24 GA) WERE BOTH QUALIFIED BY THE TEST PROCEDURE.
- THE DOOR IS DESIGNED TO COMPLY WITH THE REQUIREMENTS OF THE FLORIDA BUILDING CODE, INCLUDING THE APPLICABLE PROVISIONS FOR HIGH-VELOCITY HURRICANE ZONES (HVHZ).
- DESIGN LOAD RATING = +46.0 PSF POSITIVE WIND LOAD
-54.0 PSF NEGATIVE WIND LOAD
- WIND LOADS FOR BUILDING OPENINGS SHALL BE DETERMINED BY A PROFESSIONAL ENGINEER USING APPROPRIATE WIND SPEED AND DESIGN CRITERIA. THIS DOOR MAY BE USED WHERE ITS DESIGN LOAD MEETS OR EXCEEDS THE DESIGN LOAD REQUIRED FOR THE BUILDING OPENING.
- THE BUILDING ENGINEER SHALL VERIFY THE ADEQUACY OF THE BUILDING STRUCTURE TO WITHSTAND SUPERIMPOSED LOADS P_{xp} , P_{yp} + R_{yp} , P_{xn} and P_{yn} + R_{yn} .
- ALL WELDING SHALL BE PERFORMED BY QUALIFIED WELDERS IN ACCORDANCE WITH THE LATEST EDITION OF AWS SPECIFICATIONS. ALL WELDING ELECTRODES SHALL CONFORM TO AWS A5.1, GRADE E-70.
- ALL BOLTS AND WASHERS SHALL BE GALVANIZED STEEL OR STAINLESS STEEL WITH A MINIMUM TENSILE STRENGTH OF 60 KSI.
- DOORS SHALL BE PROVIDED WITH A SINGLE CURTAIN MOUNTED SLIDE LOCK LATCH THAT ENGAGES THE DOOR GUIDE WHEN DOOR IS FULLY CLOSED.
- DOOR ASSEMBLY DESIGN BASED ON CERTIFIED TESTING LABORATORIES, INC., TEST REPORT NO. CTLA-1115V.
- ANCHOR NOTES:
 - EMBEDMENT LENGTH DOES NOT INCLUDE STUCCO FINISH.
 - FOR HOLLOW MASONRY BLOCK, FILL ALL CELLS AT ANCHOR LOCATIONS WITH MINIMUM 2000 PSI GROUT.
 - CONCRETE JAMBS TO BE MINIMUM 2000 PSI.
 - ANCHORS SHALL BE INSTALLED IN ACCORDANCE WITH MANUFACTURER'S SPECIFICATIONS.
- GUIDE TO JAMB ATTACHMENT FASTENERS BEGIN 4" FROM FLOOR AND END 3 1/2" BELOW TOP OF WALL OPENING.
- TEST DOOR WALL OPENING SIZE: 8'-8" X 8'-0".

STRUCTURAL ENGINEER: JOSEPH H. DIXON, JR. P.E. FL #7768

UNLESS OTHERWISE SPECIFIED DIMENSIONS ARE IN INCHES AND TOLERANCES ARE:

DECIMAL	FRACTIONS	ANGLES	HOLE DIAMETERS
.XX ±.03	± 1/16	± 0° 30'	UNDER .251 +.004 -.003
.XXX ±.005			.251 to .500 +.006 -.003
			OVER .500 +.008 -.003

PART NUMBER: NA	
MATERIAL: NA	
APPLIED FINISH: NA	
UNIT OF MEASURE: NA	
APPROVALS	DATE
DRAWN: BECKY NELSON	7-25-03
CHECKED: DON MILLS	9-15-03
APPROVED: DON MILLS	9-15-03

JANUS INTERNATIONAL CORPORATION	
134 JANUS INTERNATIONAL BLVD TEMPE, GA 30179	
770-562-2850/Fax 770-562-2264	
© 2012 Janus International Corporation All Rights Reserved	
FLORIDA STATE MINI DOOR SERIES 850-S	
MAX. SIZE 8'-8" X 12'-0"	
SIZE: B	DRAWING NUMBER: T1006-S
SCALE: NONE	SHEET: 2 OF 2



Product Evaluation

GDR40 | 0318

Engineering Services Program

The following product has been evaluated for compliance with the wind loads specified in the International Residential Code (IRC) and the International Building Code (IBC).

This product evaluation is not an endorsement of this product or a recommendation that this product be used. The Texas Department of Insurance has not authorized the use of any information contained in the product evaluation for advertising, or other commercial or promotional purpose.

This product evaluation is intended for use by those individuals who are following the design wind load criteria in Chapter 3 of the IRC and Section 1609 of the IBC. The design loads determined for the building or structure shall not exceed the design load rating specified for the products shown in the limitations section of this product evaluation. This product evaluation does not relieve a Texas licensed engineer of his responsibilities as outlined in the Texas Insurance Code, the Texas Administrative Code, and the Texas Engineering Practice Act.

For more information, contact TDI Engineering Services Program at (800) 248-6032.

Evaluation ID: GDR-40

Effective Date: March 1, 2018

Re-evaluation Date: March 2022

Product Name: Series 850-S Steel Roll Up Doors, Impact Resistant

Manufacturer: Janus International Corporation
135 Janus International Blvd.
Temple, GA 30179-4435
(866) 562-2580
www.janusintl.com

General Description:

This evaluation report is for the Series 850-S steel roll up doors. The steel roll-up doors consist of a corrugated steel curtain that is suspended from a barrel. Coil springs, located within the barrel, raise and lower the curtain, which wraps around the barrel. A push-up, hand chain, or electric operation raise the steel curtain. The sides of the curtain are constrained from lateral movement along their vertical edges by steel guides that are attached to the structure. The steel roll up doors specified in this evaluation report are impact resistant. This evaluation report includes the following doors:

System	Description	Maximum Width	Maximum Height
1	26-Gauge Series 850-S Roll Up Doors; Single Curtain; Windlocks	8'-8"	12'-0"

The steel roll up doors specified in this evaluation report consist of the following components:

- **Curtain:** 26-gauge corrugated steel that is roll-formed from ASTM A 653 grade 80 steel. The corrugated sheets are galvanized and pre-painted with silicone polyester paint. The corrugated sheets are interlocked mechanically to form the curtain.
- **Guides:** 12-gauge galvanized steel roll-formed from ASTM A 653 steel. The dimensions of the guide are 2" x 4" x 0.105" x full length.

- **Wind Bar:** 12-gauge galvanized steel roll-formed from ASTM A 653 steel. The dimensions of the guide are 1.188" x 0.984" x 0.188" x 0.105" x full length of guide. Secure the wind bar to the guide with anchors.
- **Bottom Bar:** One 24-gauge galvanized steel bottom bar full length of curtain. One roll-formed steel angle, 2" x 1-1/2" x 0.105" x full length. The steel angle is attached to the steel bottom bar with 1/4" diameter thru bolts and lock nuts. Two bolts are located at each end and two bolts are located at the center. One bolt is located 12" on center. A continuous vinyl bulb astragal is attached to the bottom of the steel angle.
- **Windlocks:** 11-gauge galvanized steel. The dimensions of the windlock are 1.13" x 3.04" x 0.112". The windlock is attached to each side of the curtain at every corrugation except at the seamed corrugations and at the latch location. Each windlock is attached to the curtain with two, 3/16" diameter zinc coated rivets.
- **Hardware:** One mini latch, Type 304 stainless steel; located 39" up from the floor; attach to the curtain with four, 1/4-20 x 1/2" diameter bolts and lock nuts.

Product Identification: A label will be affixed to the bottom bar of the steel roll up door. The label must include the manufacturer's name, series number of door, the allowable design pressure rating, the design drawing number, and tested per TAS 201, 202, 203, ANSI/DASMA 108 & 115.

Limitations:

System	Maximum Width	Maximum Height	Drawing	Design Pressure Rating (psf)
1	8'-8"	12'-0"	T1006-S Rev C	+46, -54

- **Glazing:** None
- **Impact Resistance:** The doors listed in this report satisfy TDI's criteria for protection from windborne debris in the **Inland I zone** and the **Seaward zone**. The door assemblies passed the equivalent of Missile Level D as specified in ASTM E 1996. The door assemblies will not need to be protected with an impact protective system when installed in areas where windborne debris protection is required.
- **Acceptance of Smaller Assemblies:** Door assemblies with dimensions equal to or smaller than those specified above are acceptable within the limitations specified in this report.
- **Drawings (The drawing listed below shall be available at the job site):**
- **System 1:** Janus International Corporation; Mini Door Series 850-S Max. Size 8'-8" x 12'-0"; Drawing No. 1006-S, Rev C; Sheet 1 and 2 of 2; revised 8-26-13; sealed by Joseph H. Dixon, P.E., dated December 11, 2013.

Installation Instructions:

Install the steel roll up doors to the substrate using one of the following methods (refer to the design drawings referenced above for further guidance):

Bolted to cast-in-place, pre-cast concrete, or grout-filled CMU substrate:

System 1: Guide Mounting: Anchor each guide and wind bar to the substrate with minimum 3/8" x 4" Powers Wedge-Bolt anchors. Place the anchors through the wind bar, through the interior of the guide, and into the substrate. Space the anchors a maximum of 4" from the floor and 10" on center along the length of the guide. Penetrate the anchors a minimum of 3-1/2" into the substrate. If the bolt must penetrate through a wall covering, then increase the bolt length by the thickness of the wall covering material. Locate the anchors a minimum of 4-1/2" from the edge of the door opening. Grout shall be minimum 2,500 psi.

Bolted to steel substrate:

System 1: Guide Mounting: The steel substrate must be minimum 1/8" thick A36 steel. Anchor each guide and wind bar to the substrate with minimum 1/4-14 x 1" ITW Buildex self-drilling TEKS screws. Place the screws through the wind bar, through the interior of the guide, and into the substrate. Space the screws a maximum of 4" from the floor and 10" on center along the length of the guide through the pre-drilled holes in the guide. If the screws must penetrate through a wall covering, then increase the bolt length by the thickness of the wall covering material.

Note: Keep the manufacturer's installation instructions available on the job site during installation. Use corrosion resistant fasteners as specified in the IRC, the IBC, and the Texas Revisions.