

HEADROOM REQUIRED

OPENING HEIGHT	VERTICAL HEADROOM	HORIZONTAL HEADROOM
THRU 7'-4"	15 1/2"	17"
OVER 7'-4" THRU 8'-8"	16"	17 1/2"
OVER 8'-8" THRU 10'-0"	17"	18 1/2"
OVER 10'-0" THRU 12'-0"	18"	19"

NOTES:

- OPERATION TYPE MAY BE PUSH-UP, CHAIN HOIST OR ELECTRIC.
- FOR CRITICAL FITS DUE TO REDUCED AVAILABLE HEADROOM OR SIDEROOM CLEARANCES, CONSULT FACTORY.
- CLEARANCES SHOWN ARE MAXIMUMS. LESSER CLEARANCES MAY BE POSSIBLE.
- UNLESS OTHERWISE NOTED, LOCKING SHALL BE BY SINGLE MINI SLIDE LATCH BOLTED TO CURTAIN AND SUITABLE FOR DOUBLE PADLOCKS AND SINGLE CYLINDER LOCK BY OTHERS.
- LATCH COVER IS YELLOW ZINC (STAINLESS STEEL, OPTIONAL) AND SLIDE IS MAGNETIC STAINLESS.
- CURTAIN FINISH SHALL BE SILICONE POLYESTER PRE-PAINT OVER GALVANIZED GRADE 80 STEEL.
- GUIDES, BRACKETS, BOTTOM BAR ANGLE AND HEAD STOPS ARE ZINC COATED.
- MAXIMUM OPENING SIZE: 850S: 12'-0" X 12'-0"; 850IM & 850D: 8'-8" X 12'-0".
- JANUS MODEL 850 IS A MIAMI DADE COUNTY APPROVED WINDLOAD PRODUCT. PRODUCT EVALUATIONS AND STAMPED DRAWINGS ARE ACCESSIBLE VIA: www.miamidade.gov.
- JANUS MODEL 850S IS A STATE OF FLORIDA APPROVED WINDLOAD PRODUCT. PRODUCT EVALUATIONS AND STAMPED DRAWINGS ARE ACCESSIBLE VIA: www.floridabuilding.org, FL#21450
- JANUS MODEL 850S IS EVALUATED FOR COMPLIANCE THROUGH TEXAS DEPARTMENT OF INSURANCE (TDI). PRODUCT EVALUATIONS AND STAMPED DRAWINGS ARE ACCESSIBLE VIA: www.tdi.texas.gov, TD# GDR-40.

BRACKET ATTACHMENT

CONCRETE/MASONRY: POWERS WEDGE-BOLT, 3/8" X 1 3/4" LONG
WOOD: LAG SCREW, 3/8" - 7 X 3" LONG
STEEL: HEX BOLT, GR.5, 3/8" - 16 X 1 1/2" LONG

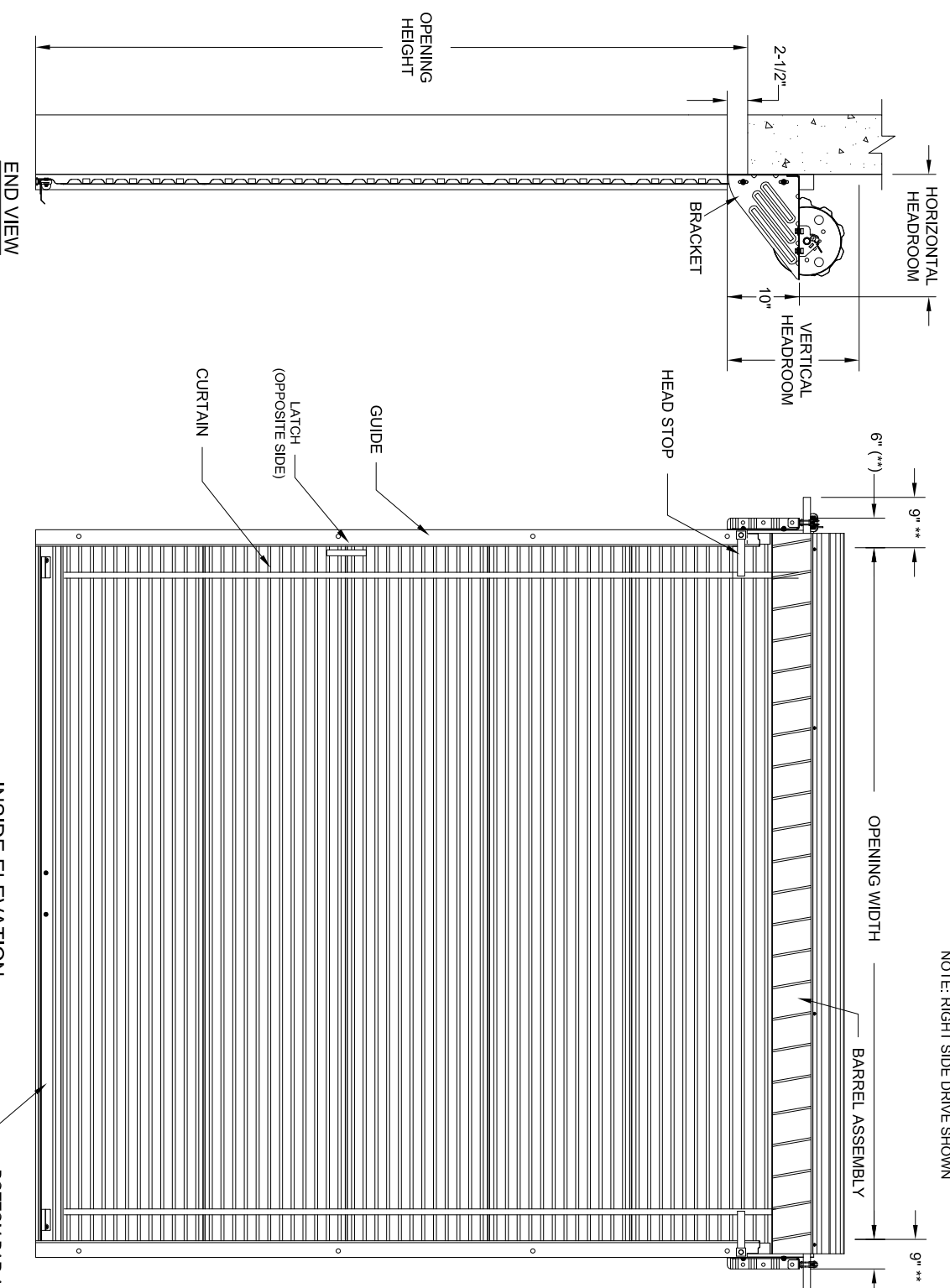

(**) DIMENSIONS SHOWN ARE FOR MOUNTING TO STEEL JAMBS. ADD 1/4" WHEN ATTACHING TO CONCRETE OR FILLED BLOCK JAMBS.

(*) FOR PUSH-UP OPERATION STL: 6" (**) FOR HAND CHAIN OPERATION STL: 6.5" (**) FOR ELECTRIC OPERATION STL: 7.5" (**) FOR OUTSIDE OF CHAIN DRIVE STL: 7" (**) NOTE: RIGHT SIDE DRIVE SHOWN

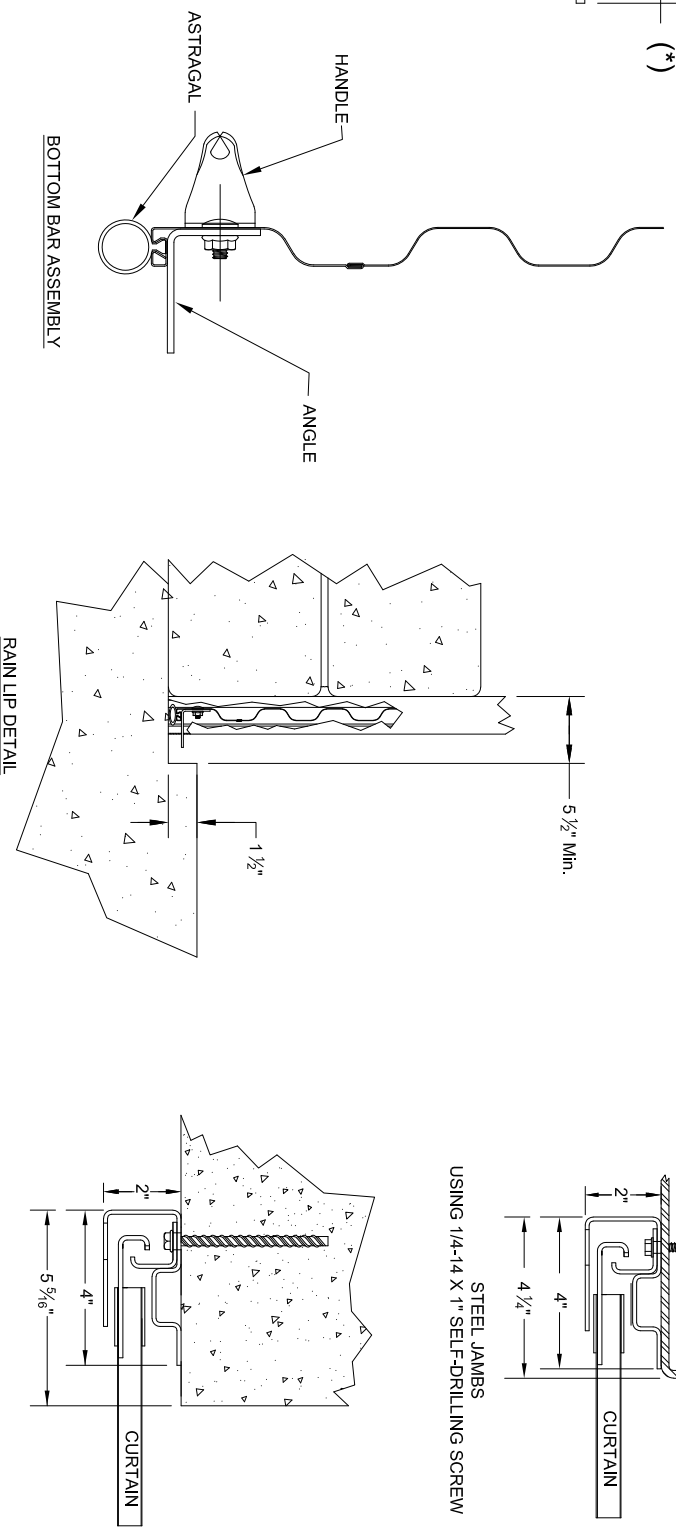
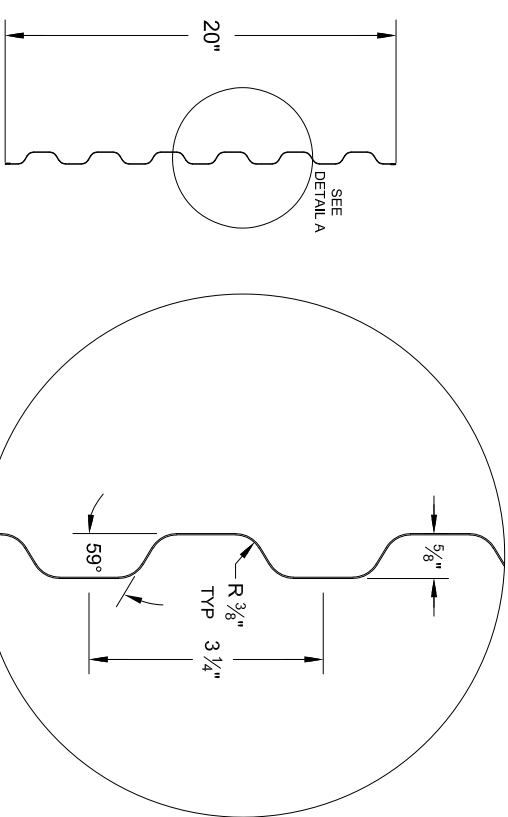
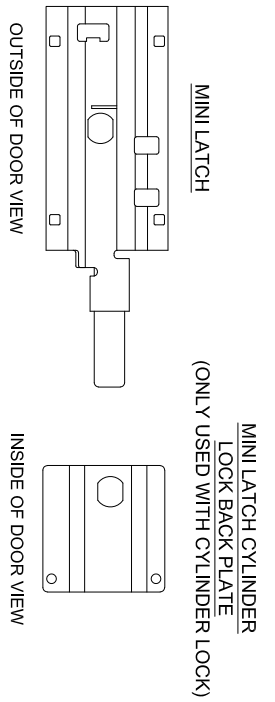

CONCRETE/FILLED BLOCK JAMBS USING 3/8" X 4" POWERS WEDGE BOLT
12 GA. GUIDE MOUNTING DETAIL

INSIDE ELEVATION

FACTORY ORDER NUMBER	DOOR SERIES		QTY	OPENING SIZE		JAMB TYPE		OUTSIDE CURTAIN COLOR	PUSH UP	REDUCED CHAIN	ELECTRIC	OPERATION HAND	WEATHERSTRIP		ADDED OPTIONS	
	850M	850D		WIDTH	HEIGHT	STEEL	CONC./MAS						TOP	HEADER		SIDE
850S	850M	850D														

MINI DOOR SERIES: 850S/850IM/850S

CUSTOMER NUMBER: _____ DATE: _____

CUSTOMER NAME: _____ CONTACT: _____

PROJECT NAME: _____

PROJECT LOCATION: _____

PLANT: _____

DRAWN BY: _____ DATE: _____

DRAWING NUMBER: _____ SHT: _____ OF: _____

JANUS INTERNATIONAL GROUP, LLC.
 135 JANUS INTERNATIONAL BLVD.
 TEMPLE, GA 30179-4435
 770-562-2850 FAX: 770-562-2264

C.S. 08/31/2021