

### Manufacturing Capabilities

#### Turning

- Standard: 1/4" to 6" diameter
- Custom: to 8" diameter

#### Milling

- Standard: 8" x 12"
- Custom: 12" x 20"

#### Machining Tolerances

- Standard: +/- .0001

#### Gear Cutting: Gears and Racks

- Standard: 16DP to 120DP
- Custom: to 200DP

### SDP/SI Machining Capabilities:

- Deburring Department
- Drilling Equipment
- Gear Cutting Equipment, CNC and Non-CNC
- Grinding Equipment
- Honing Machines
- Lathes, CNC and Non-CNC
- Milling Machines and Machining Centers, CNC
- Plastic Injection Molds
- Plastic Injection Machines
- Swiss Turn Machines
- Timing Belt Slicing Machines
- Timing Belt Ink Jet Printers
- Ultrasonic Welders
- Miscellaneous Equipment
- Certified Inspection & Test Equipment
- SPC Capabilities

#### Gear Cutting: Worms and Worm Wheels

- Standard: 16DP to 72DP

#### Gear Cutting Tolerances

- Molded Gears: AGMA 5
- Machined Gears: to AGMA 14

#### Custom Precision Shafting

- 1/32" to 1-1/2" diameter
- Tolerance: +/- .0001"
- Straightness: up to .0003"/Inch
- Length: up to 12 feet

# SHAFTLOC®

A Superior Way to Fasten Rotating Parts

Nonmarring to the shaft  
Installs with standard tools  
Reusable



# SDP/SI

PHONE: 516.328.3300 • FAX: 516.326.8827 • WWW.SDP-SI.COM

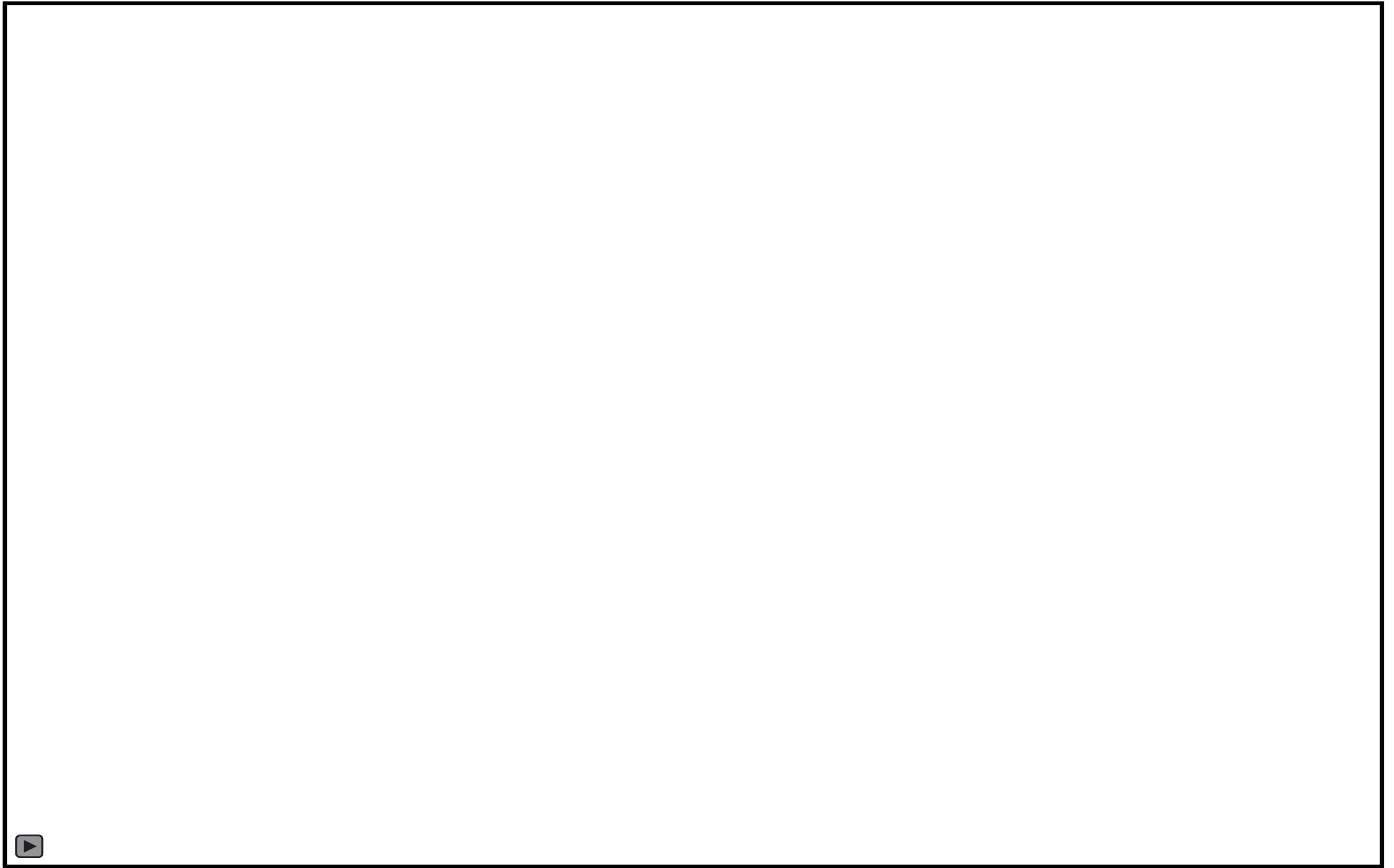

# SDP/SI is the go-to source for synchronous drive components. As a full service manufacturer SDP/SI understands complex problems and provides exceptional solutions.

We are a leading manufacturer and supplier of timing pulleys, timing belts, gears, couplings, bearings and other mechanical drive components. Known as the go-to source for synchronous drive components, Stock Drive Products has built a reputation among designers of small mechanisms and drives for having all the finest quality products on hand. We can provide prototype to large production quantities.

We are able to cut timing belt widths to your exact specifications from our vast inventory of sleeves. Whether the parts are custom or off-the-shelf, our engineering team will help you determine the most cost-effective solution while maintaining optimum quality.

## Plastic Molding Capabilities

SDP produces durable, lightweight and cost effective standard and custom plastic pulleys, gears and other drive components. At our molding facility, we manufacture AGMA 5 – 10 quality products that are RoHS and REACH compliant. With years of experience, large capacity and delivery when you need it, SDP is the right choice.

Sterling Instrument is unsurpassed as a manufacturer of custom and standard precision gears, gear assemblies, gearboxes and custom aerospace components.

Our fine to medium pitch gears are manufactured to AGMA 14 for some of the most demanding customers in the aerospace, defense, and medical industries of today. Our expertise is not limited to gear making; it also includes the design and production of precision gear assemblies, gearboxes, differentials, speed reducers and other motion control products.

Sterling applies strict quality control throughout the entire manufacturing cycle.

Comprehensive engineering experience enables us to offer the additional services of design review and / or value engineering toward the goal of manufacturing efficiency. An on-site Class 10000 clean room is used for testing, assembly and packaging. NADCAP and customer approved facilities are used for casting, heat-treating, plating, and painting. We can machine many materials, such as aluminum, brass, bronze, steel alloys, stainless steel, and titanium.

Precise equipment yields precise results.

Sterling Instrument's commitment to high quality results in superior products. We offer  $\pm .0001$ " tolerances by employing state-of-the-art CNC machining equipment. We use the newest technology to provide our customers with the best products possible. As a CNC manufacturer, we excel in every aspect of the process:



# SDP/SI

PHONE: 516.328.3300 • FAX: 516.326.8827 • WWW.SDP-SI.COM

# A SUPERIOR WAY TO FASTEN ROTATING COMPONENTS

Excelling because of its simplicity, Shaftloc® contains only two parts. It is a patented device (United States Patent No. 5,067,846 and No. 6,000,875), manufactured and marketed by SDP/SI. In order to highlight the simplicity and uniqueness of the Shaftloc® design, we will list some of the typical methods used for fastening rotating components:

The usefulness of wedges and inclined surfaces for lifting heavy loads has been implemented for centuries.

Similarly, tapered conical surfaces have traditionally been utilized to produce large forces.

One example is the use of a tapered split bushing to fasten a rotating component to a shaft. The axial force from tightening the bolts translates into amplified radial forces that close the split bushing.

The main disadvantage of this particular method is that the component must have a tapered bore. The process can be modified, however, by adding a transition plate with a tapered bore (see Fig. 1). In this case, the component can have a plain bore.

An alternative method involves a series of rings. Two solid rings are assembled around two split rings with bolts (see Fig. 2).

Tightening the bolts causes the inner split ring to contract and the outer split ring to expand, producing large forces in the direction of both the component and the shaft. As a result, the two are held in place with respect to one another.

A third method uses a slotted inner sleeve and slotted outer sleeve (see Fig. 3). The inner threaded sleeve is moved axially when the nut around it is tightened.

Because both surfaces are tapered, the axial motion produces radial forces in both the direction of the component and the direction of the shaft. This method is often used to fasten smaller components.

The last method, similar to the third, uses a slotted and threaded inner sleeve and a split outer sleeve (see FIG. 4). However, this one has parallel, side-by-side inclined grooves instead of a continuous conical surface. Also, the nut has additional set screws around it that produce relative displacement between the inner and outer sleeves.

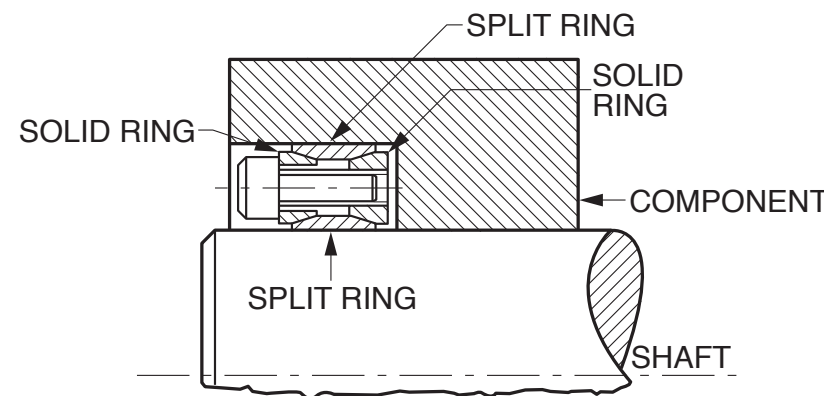
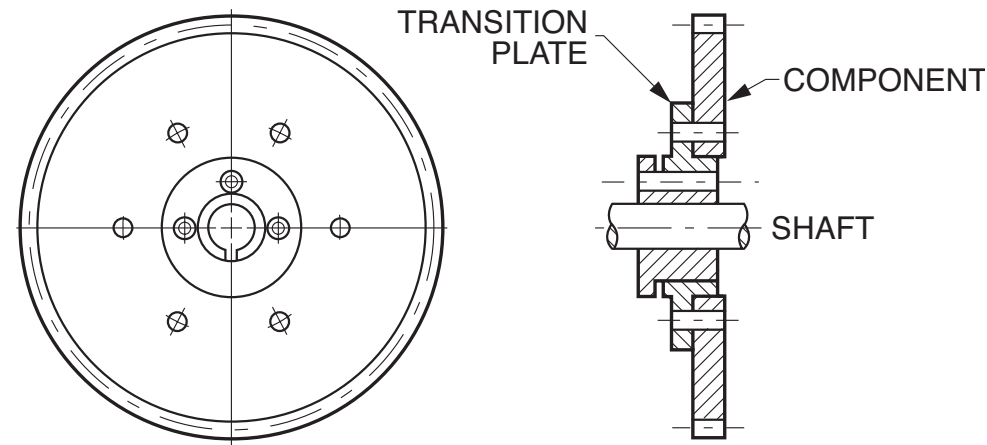

FIG. 2

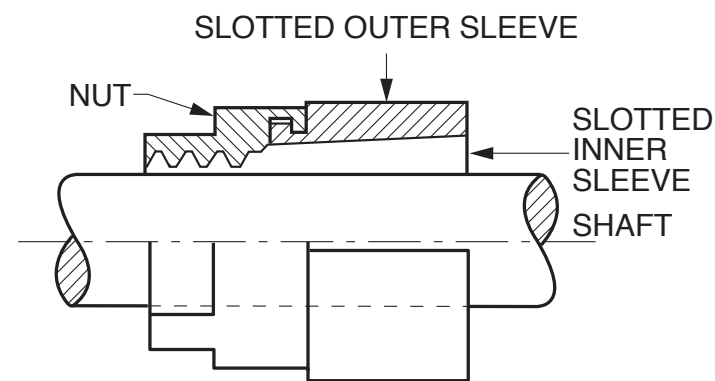

FIG. 3

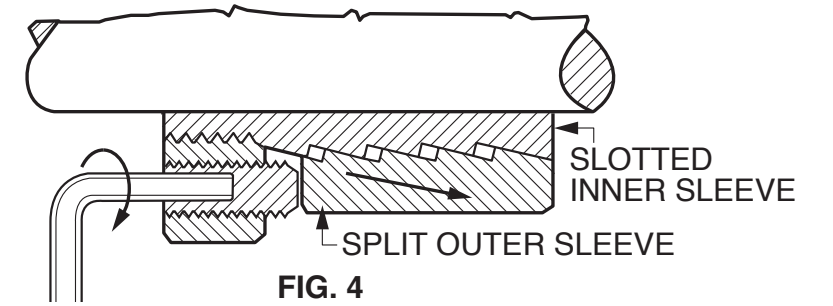

FIG. 4

In turn, this displacement produces axial forces that translate into radial forces, and fasten the component to the shaft. This method is only suitable for larger sized components, where the nut can accommodate a number of set screws.

Fastening Methods shown in FIG. 1 through FIG. 4 are all functional. However, the Shaftloc® design is the ULTIMATE fastening method for the following reasons:

## Shaftloc® has only two parts:

A slotted outer sleeve and a slotted inner sleeve, both of which have hexagonal heads. The outer sleeve is cylindrical on its outside diameter, and threaded on its inside diameter. Conversely, the inner sleeve is threaded on its outside diameter, and cylindrical on its inside diameter.

## Unique thread profile:

The thread is unique in that it is not symmetrical, which creates a continuous inclined surface. The shallow angle of the thread produces large amplifications of forces, resulting in substantial torque transmission capability between the component and the shaft.

## Style 1 (Double Ended):

The hexes are oriented on opposite sides, clamping the component between them. Tightening the sleeves will cause the outer one to expand and the inner one to contract.

## Style 2 (Single Ended):

Similar to style 1, tightening the sleeves will cause the outer one to expand and the inner one to contract. In this case, the hexes are oriented on the same side, leaving one face of the fastened component unobstructed.

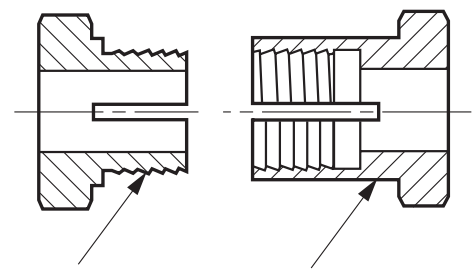

**STYLE 1:  
A 7Z37-series  
Double-Ended**

INNER SLEEVE    OUTER SLEEVE

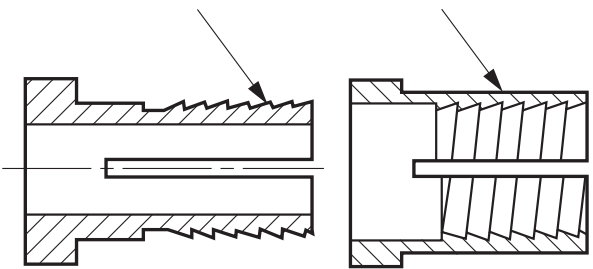

**STYLE 2:  
A 7Z39-series  
Single-Ended**

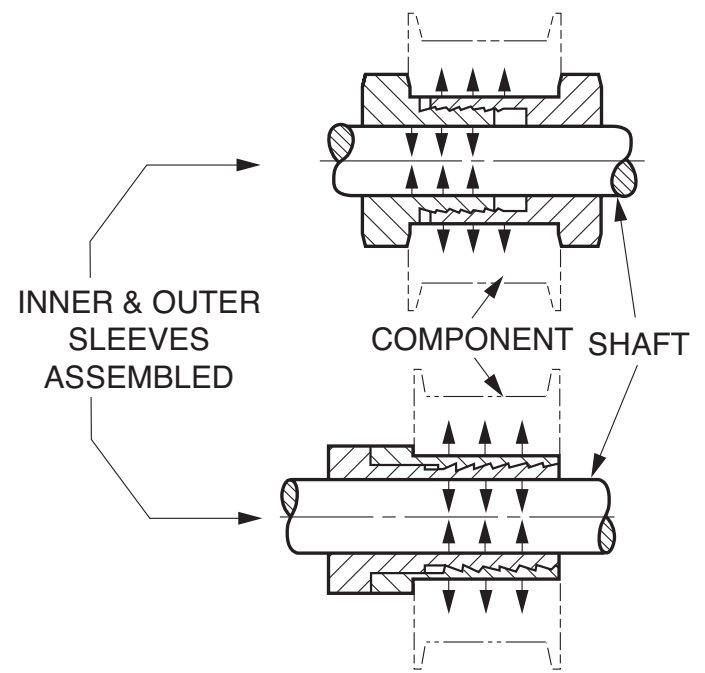

**STYLE 1:  
Double-Ended**

**STYLE 2:  
Single-Ended**

**Style 3 (M-type):**  
Consists of a slotted hex bolt and a hex nut. Used as a locking device for rigidly mounting mechanical components on a shaft. The asymmetric threads create a constant inclined contact, generating large radial clamping forces. Tightening the nut against to the component causes the slotted sleeve to contract, gripping the shaft and clamping the component to the bolt at the same time.

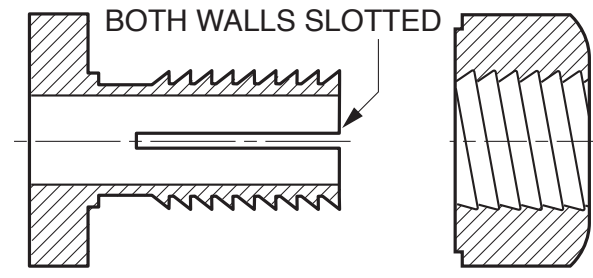
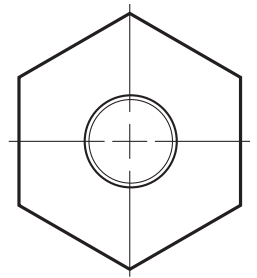

**STYLE 3:  
Shaftloc®  
M-Type**

SLEEVE    NUT

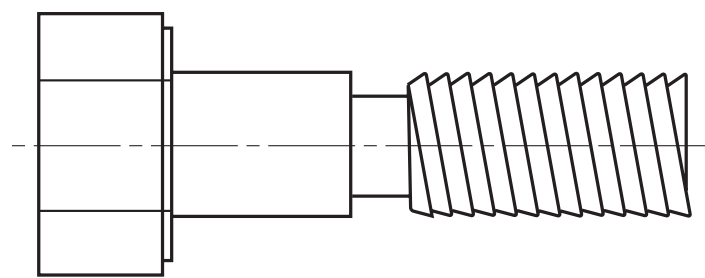
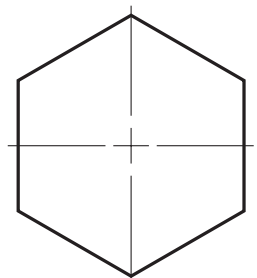

**STYLE 4:  
Shaftloc®  
A-Type**

BOLT    NUT

**Style 4 (A-Type):**  
Similar to style 3, the asymmetric threads create a tight, self-locking wedge that reduces vibrations in the clamped components, but the bolt is solid, with a shoulder.

**DISTINCT ADVANTAGES OF SHAFTLOC® OVER OTHER FASTENING DEVICES:**

- Simplicity of design – few parts
- No marring of shafts
- Easy repositioning or synchronizing of rotating components
- Ease of assembly
- Applicable for small shaft diameters
- All stainless steel construction
- Can be used for stationary breadboard or production structures
- Low-cost



# SINGLE-ENDED SHAFTLOC® SLEEVES

EASY ASSEMBLY  
NO MARRING OF SHAFTS

**MATERIAL:** 416 Stainless Steel

## METRIC Components

Catalog Number	d Bore +0.025 0	D Dia. 0 -0.025	A Hex Size	L	l	H	Max. Torque Capacity N • m
A 7Z39M0306	3	6	8	13.2	10	3.17	1.1
A 7Z39M0408	4	8	10	15.2	12	3.17	2.8
A 7Z39M0610	6	10	13	15.6	12	3.6	3.3
A 7Z39M0812	8	12	15	20	16	4	9.9
A 7Z39M1016	10	16	19	20	16	4	11
A 7Z39M1218	12	18	21	25.5	20	5.6	16.5
A 7Z39M1420	14	21	27	28.3	20	8.25	18.6
A 7Z39M1622	16	24	30	33.2	25	8.25	20.6
A 7Z39M1825	18	27	32	43	25	9.02	22.8

### SPECIFICATIONS:

For optimum performance, the clearances between the shaft, Shaftloc® and housing should not exceed 0.0254 mm.

Maximum torque capacity based on mating components being degreased before assembly with Shaftloc® coupling.

Can be used with Precision Ground Shafting, Catalog Number **A 7X 1M...**

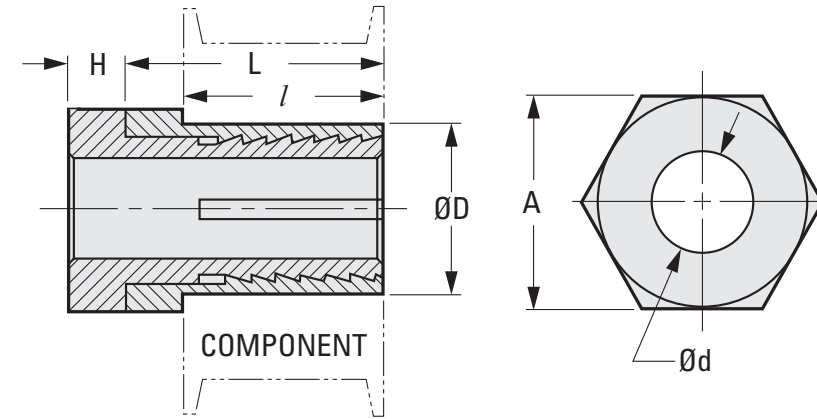

The projections shown are per ISO convention.

## INCH Components

Catalog Number	B Bore +.001 -.000	O.D. Dia. +.000 -.001	H Hex Size	L	E	C	Max. Torque Capacity lbf in.
A 7Z39-0408	.125	.250	3/8	1/2	.375	1/8	15
A 7Z39-0612	.1875	.375	1/2	21/32	.500	5/32	55
A 7Z39-0812	.250	.375	1/2	21/32	.500	5/32	100
A 7Z39-0816	.250	.500	5/8	13/16	.625	3/16	200
A 7Z39-1216	.375	.500	5/8	13/16	.625	3/16	250
A 7Z39-1220	.375	.625	3/4	15/16	.750	7/32	250
A 7Z39-1624	.500	.750	7/8	15/16	.750	7/32	250

### SPECIFICATIONS:

For optimum performance, the clearances between the shaft, Shaftloc® and housing should not exceed .001".

Maximum torque capacity based on mating components being degreased before assembly with Shaftloc® coupling.

Can be used with Precision Ground Shafting, Catalog Number **A 7X 1-...**

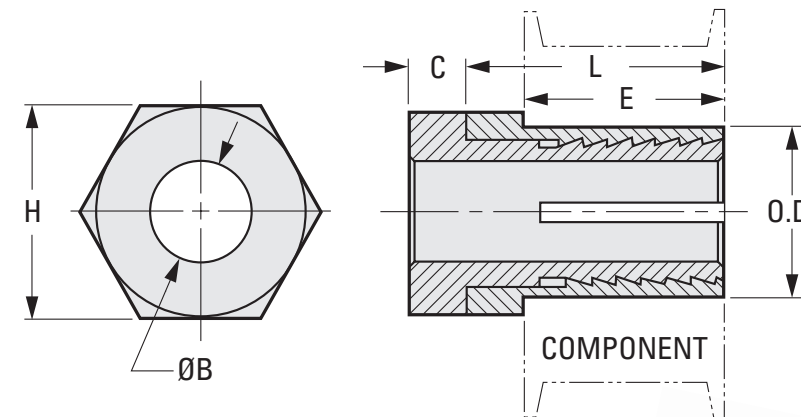

Go to: <http://www.sdp-si.com/videos/Shaftloc.php> for a quick instructional.

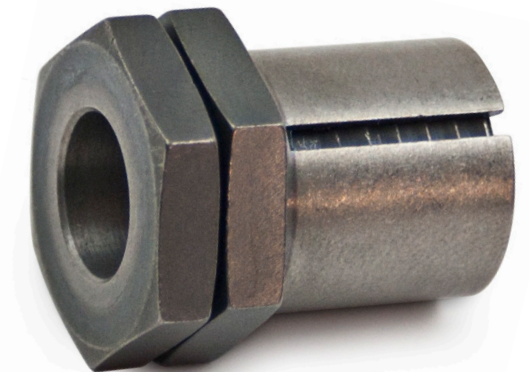

# SDP/SI

PHONE: 516.328.3300 • FAX: 516.326.8827 • WWW.SDP-SI.COM

# DOUBLE-ENDED SHAFTLOC® SLEEVES

**3/8" & 1/2" BORE**  
EASY ASSEMBLY

**MATERIAL:** 416 Stainless Steel

## INCH Components

Catalog Number	See Note	Pulley Bore +.001 -.000	B Bore +.001 -.000	W Width	H Hex Size	Max. Torque Capacity N • m
A 7Z37-030553	1	.625	.375	.52 - .62	3/4	250
A 7Z37-030578	1	.625	.375	.75 - .85	3/4	250
A 7Z37-040670	2	.750	.500	.72 - .83	7/8	250

### SPECIFICATIONS:

Can be used with Precision Ground Shafting,  
Catalog Number **A 7X 1-...**

### Notes:

1. A 3/4" O.D. x 5/8" I.D. x .05" thick washer, Catalog Number **A 7X 8-C20050** is supplied.
2. A 7/8" O.D. x 3/4" I.D. x .05" thick washer, Catalog Number **A 7X 8-C24050** is supplied.

\*Based on mating components being degreased before assembly with Shaftloc® coupling.

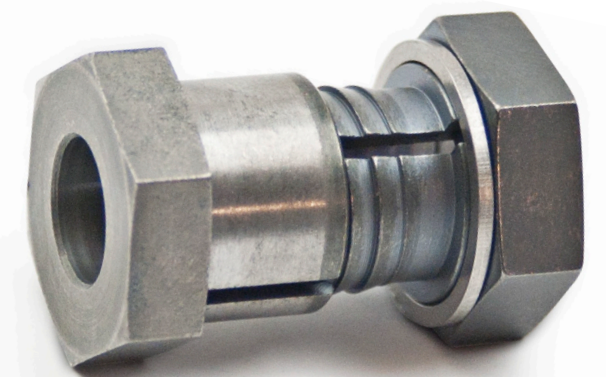
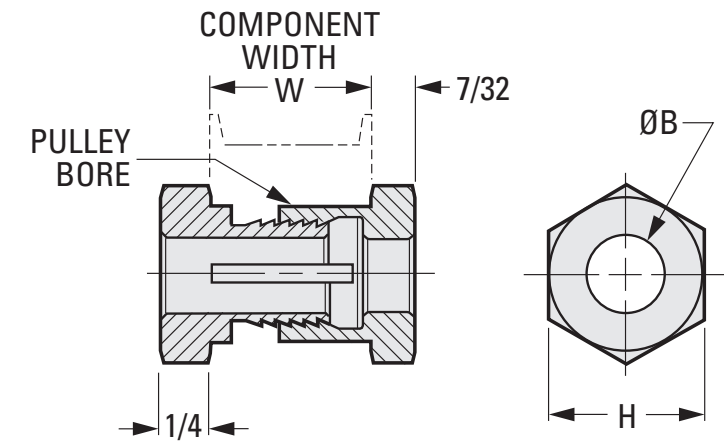

**SDPSI**

PHONE: 516.328.3300 • FAX: 516.326.8827 • WWW.SDP-SI.COM

# A-TYPE SHAFTLOC®

SELF-LOCKING  
VIBRATION-RESISTANT  
INSTALLED WITH STANDARD TOOLS  
REUSABLE

**MATERIAL:** 416 Stainless Steel, Passivated

## METRIC Components

Catalog Number	A Dia. 0 -0.05	L	B	C	D	E
A 7Z38M0619	6.5	19	19	4	10	6.1
A 7Z38M0625	6.5	25	19	4	10	6.1
A 7Z38M0632	6.5	32	19	4	10	6.1
A 7Z38M0820	8	20	20	5	14	7
A 7Z38M0825	8	25	20	5	14	7
A 7Z38M0832	8	32	20	5	14	7
A 7Z38M1025	10	25	25	7	16	8.9
A 7Z38M1032	10	32	25	7	16	8.9
A 7Z38M1038	10	38	25	7	16	8.9
A 7Z38M1332	13	32	32	8	18	11.7
A 7Z38M1338	13	38	32	8	18	11.7
A 7Z38M1345	13	45	32	8	18	11.7

## INCH Components

Catalog Number	A Dia. +.000 -.002	L	B	C	D	E
A 7Z38-0812	.2500	.75	.75	.16	.44	.23
A 7Z38-0816	.2500	1.00	.75	.16	.44	.23
A 7Z38-0820	.2500	1.25	.75	.16	.44	.23
A 7Z38-1012	.3125	.75	.75	.20	.50	.27
A 7Z38-1016	.3125	1.00	.75	.20	.50	.27
A 7Z38-1020	.3125	1.25	.75	.20	.50	.27
A 7Z38-1216	.3750	1.00	1.00	.29	.56	.34
A 7Z38-1220	.3750	1.25	1.00	.29	.56	.34
A 7Z38-1224	.3750	1.50	1.00	.29	.56	.34
A 7Z38-1620	.5000	1.25	1.25	.32	.75	.45
A 7Z38-1624	.5000	1.50	1.25	.32	.75	.45
A 7Z38-1628	.5000	1.75	1.25	.32	.75	.45

**SPECIFICATIONS:**  
Special sizes available upon request.

Sold in pairs

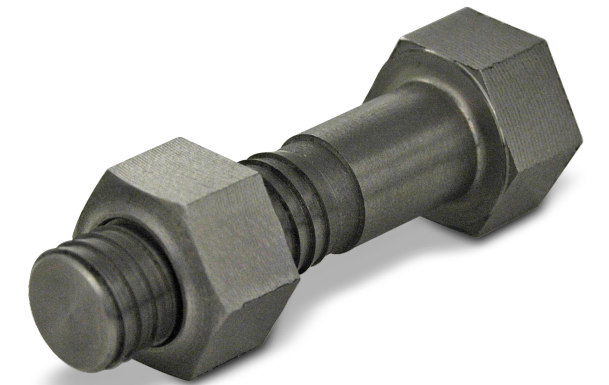
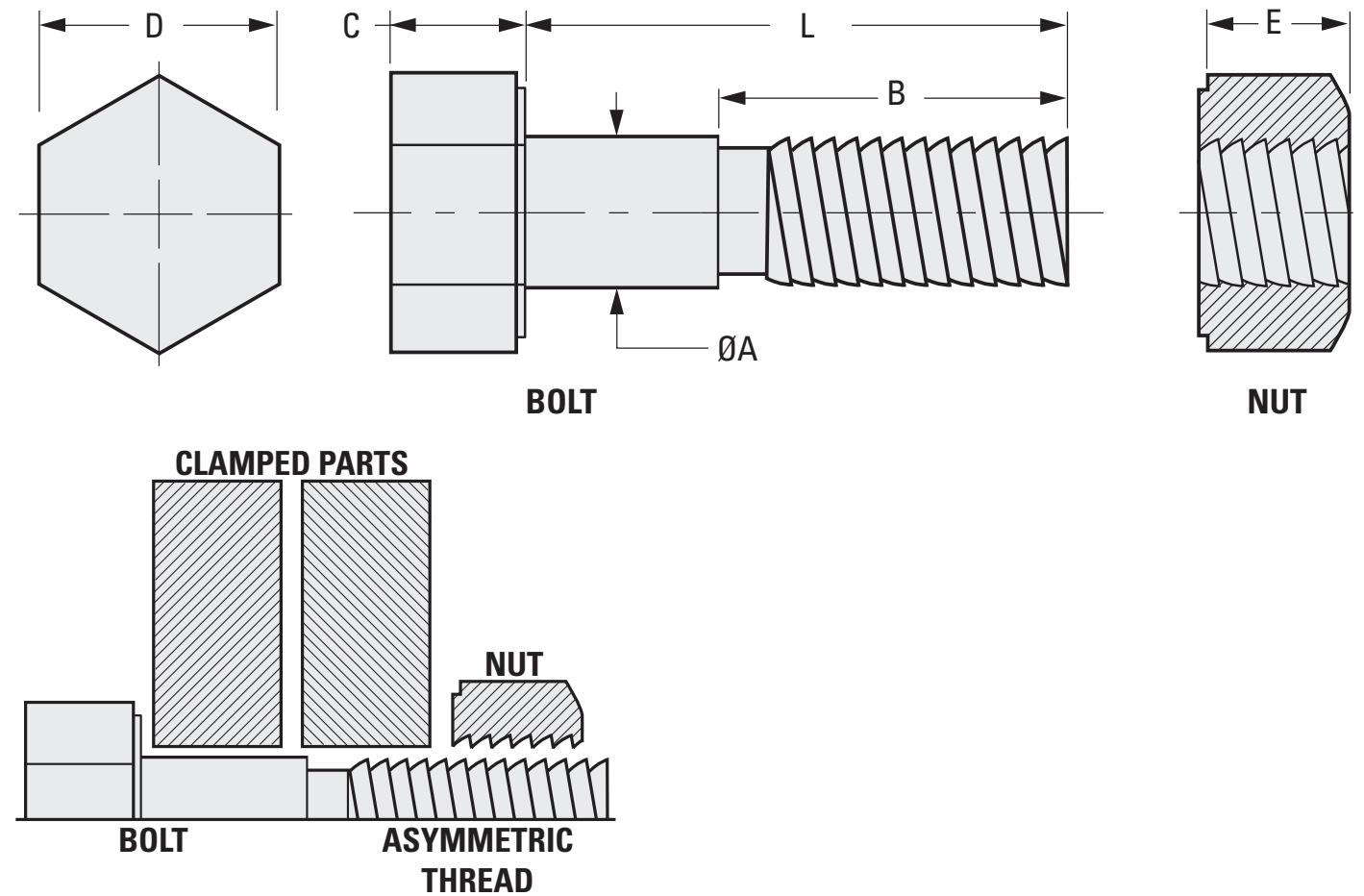

# SDPSI

PHONE: 516.328.3300 • FAX: 516.326.8827 • WWW.SDP-SI.COM

# M-TYPE SHAFTLOC®

SELF-LOCKING  
VIBRATION-RESISTANT  
NONMARRING OF SHAFT  
INSTALLED WITH STANDARD TOOLS  
REUSABLE

**MATERIAL:** 416 Stainless Steel, Passivated

## METRIC Components

Catalog Number	A Dia. +0.025 0	B Dia. 0 -0.025	C	D	E	L
A 7Z36M0612	6	10	14	4	7	12
A 7Z36M1016	10	14	18	4	12	16
A 7Z36M1218	12	16	24	5	14	18

Diameters A and B concentric within 0.013 T.I.R.

## INCH Components

Catalog Number	A Dia. +.001 -.000	B Dia. +.000 -.001	C	D	E	L
A 7Z36-0842	.250	.3125	.50	.15	.27	.42
A 7Z36-1260	.375	.500	.75	.15	.45	.60
A 7Z36-1671	.500	.625	.94	.20	.56	.71

Diameters A and B concentric within .0005 T.I.R.

### SPECIFICATIONS:

Can be installed on shafts with existing keyways.

Special sizes available upon request.

Sold in pairs

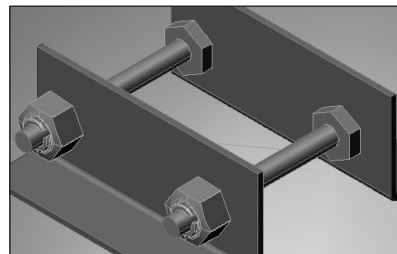
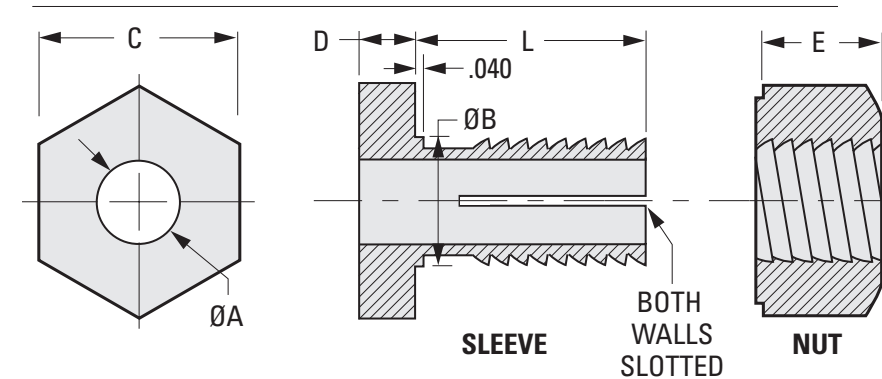
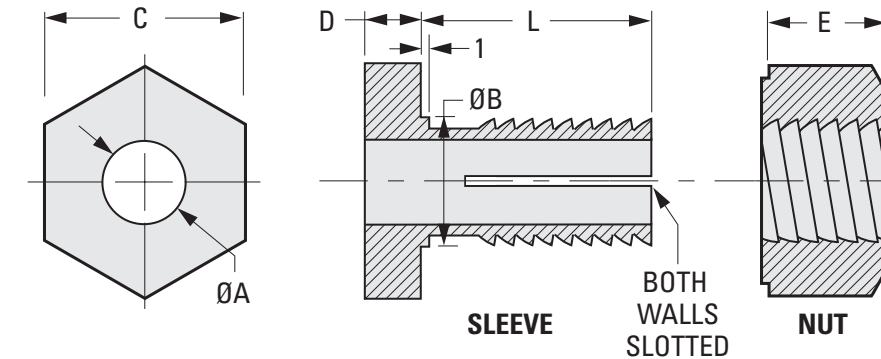

A superior method for building frames, or mounting shafts, pins, rails or any cylindrical components to thin sheet metal or plastic walls.

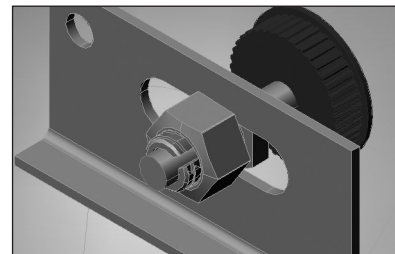

Ideal in slots or oversized holes used for shaft position or belt tension adjustment applications.



Mounts hubless gears, sprockets, pulleys, cams or any thin walled components onto a shaft. Offers infinite radial and axial adjustments and quick lock and release action.

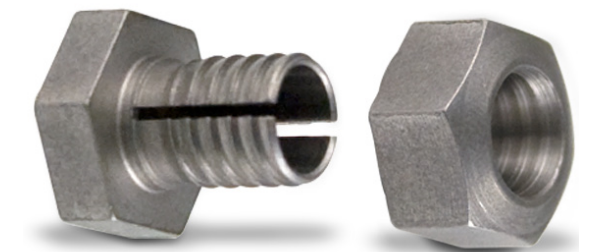

# SDPSI

PHONE: 516.328.3300 • FAX: 516.326.8827 • WWW.SDP-SI.COM

# XL PULLEYS FOR SHAFTLOC®

## 1/5" PITCH

**FOR 3/8" BELTS**  
 MOLDED WITH METAL INSERT  
 SINGLE OR DOUBLE FLANGE

**MATERIAL:** Pulleys: Nylon - Black, Fiberglass Reinforced  
 Insert: Steel, Overmolded

### INCH Components

Catalog Number		No. of Grooves	P.D.	O.D.	F.D.
Single Flange Fig. 1	Double Flange Fig. 2				
A 6T 3-H18SF3720	A 6T 3-H18DF3720	18	1.146	1.126	1.38
A 6T 3-H19SF3720	A 6T 3-H19DF3720	19	1.210	1.190	1.43
A 6T 3-H20SF3720	A 6T 3-H20DF3720	20	1.273	1.253	1.50
A 6T 3-H21SF3720	A 6T 3-H21DF3720	21	1.337	1.317	1.57
A 6T 3-H22SF3720	A 6T 3-H22DF3720	22	1.401	1.381	1.63
A 6T 3-H24SF3720	A 6T 3-H24DF3720	24	1.528	1.508	1.76
A 6T 3-H25SF3720	A 6T 3-H25DF3720	25	1.592	1.572	1.80
A 6T 3-H26SF3720	A 6T 3-H26DF3720	26	1.655	1.635	1.87
A 6T 3-H27SF3720	A 6T 3-H27DF3720	27	1.719	1.699	1.93
A 6T 3-H28SF3720	A 6T 3-H28DF3720	28	1.783	1.763	2.01
A 6T 3-H29SF3720	A 6T 3-H29DF3720	29	1.846	1.826	2.07
A 6T 3-H30SF3720	A 6T 3-H30DF3720	30	1.910	1.890	2.14
A 6T 3-H32SF3720	A 6T 3-H32DF3720	32	2.037	2.017	2.27
A 6T 3-H36SF3720	A 6T 3-H36DF3720	36	2.292	2.272	2.52
A 6T 3-H40SF3720	A 6T 3-H40DF3720	40	2.546	2.526	2.78
A 6T 3-H42SF3720	A 6T 3-H42DF3720	42	2.674	2.654	2.90
A 6T 3-H48SF3720	A 6T 3-H48DF3720	48	3.056	3.036	3.29
A 6T 3-H60SF3720	A 6T 3-H60DF3720	60	3.820	3.800	4.05

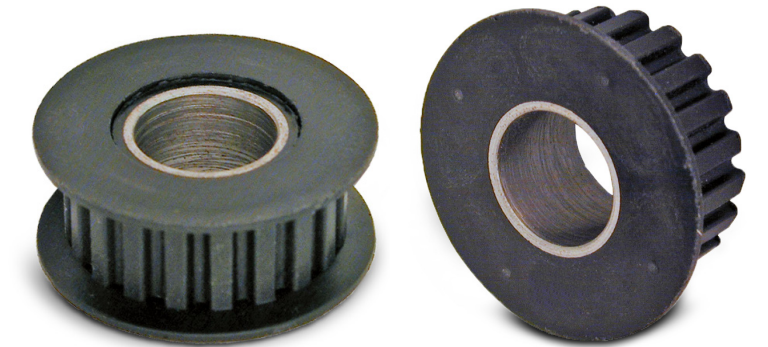
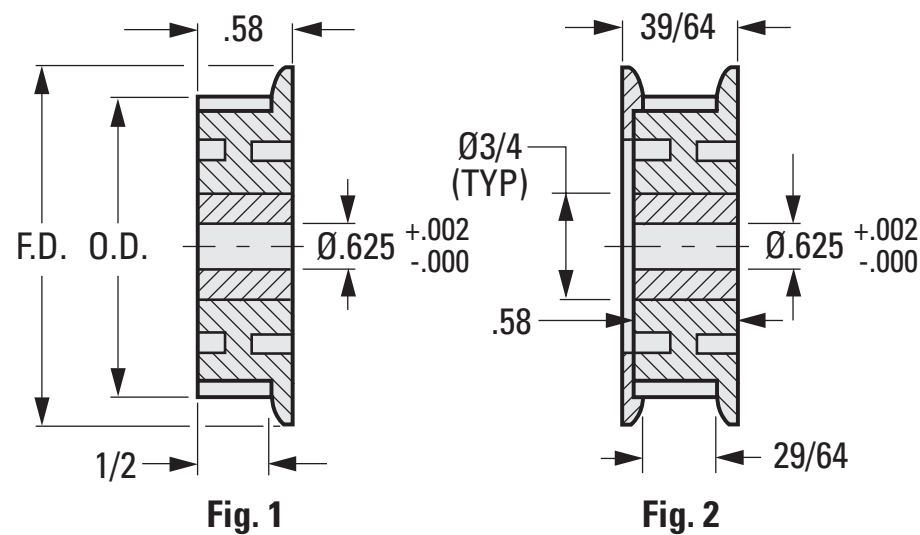

### APPLICABLE SHAFTLOC® SLEEVE

Catalog Number	Pulley Bore (Ref.)	Max. Torque Capacity* lbf in.
A 7Z37-030553	.625	250

**SPECIFICATIONS:**  
 A 3/4" O.D. x 5/8" I.D. x .05" thick washer, Catalog Number **A 7X 8-C20050** is supplied.

\*Based on mating components being degreased before assembly with Shaftloc® coupling.

Aluminum pulleys to mate with Shaftloc® are available upon request.

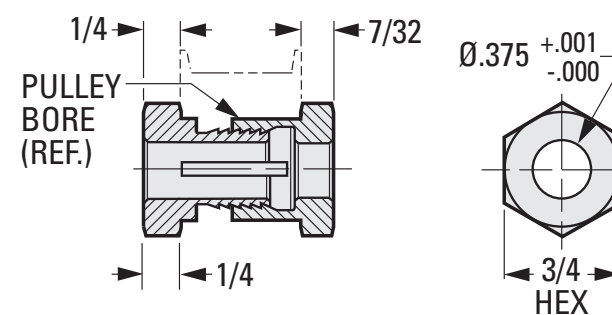

**MATERIAL:** 416 Stainless Steel



# L PULLEYS FOR SHAFTLOC®

## 3/8" PITCH

**FOR 1/2" BELTS**  
 MOLDED WITH METAL INSERT  
 SINGLE OR DOUBLE FLANGE

**MATERIAL:** Pulleys: Nylon - Black, Fiberglass Reinforced  
 Insert: Steel, Overmolded

### INCH Components

Catalog Number		No. of Grooves	P.D.	O.D.	F.D.	B Dia. +.002 -0.000	C Dia.
Single Flange Fig. 1	Double Flange Fig. 2						
A 6T 4-H10SF5020	A 6T 4-H10DF5020	10	1.194	1.164	1.49	.625	3/4
A 6T 4-H11SF5020	A 6T 4-H11DF5020	11	1.313	1.283	1.63	.625	3/4
A 6T 4-H12SF5020	A 6T 4-H12DF5020	12	1.432	1.402	1.75	.625	3/4
A 6T 4-H13SF5024	A 6T 4-H13DF5024	13	1.552	1.522	1.79	.750	1
A 6T 4-H14SF5024	A 6T 4-H14DF5024	14	1.671	1.641	2.00	.750	1
A 6T 4-H15SF5024	A 6T 4-H15DF5024	15	1.790	1.760	2.12	.750	1
A 6T 4-H16SF5024	A 6T 4-H16DF5024	16	1.910	1.880	2.22	.750	1
A 6T 4-H17SF5024	A 6T 4-H17DF5024	17	2.029	1.999	2.34	.750	1
A 6T 4-H18SF5024	A 6T 4-H18DF5024	18	2.149	2.119	2.47	.750	1
A 6T 4-H19SF5024	A 6T 4-H19DF5024	19	2.268	2.238	2.57	.750	1
A 6T 4-H20SF5024	A 6T 4-H20DF5024	20	2.387	2.357	2.74	.750	1
A 6T 4-H21SF5024	A 6T 4-H21DF5024	21	2.507	2.477	2.85	.750	1
A 6T 4-H22SF5024	A 6T 4-H22DF5024	22	2.626	2.596	2.95	.750	1
A 6T 4-H24SF5024	A 6T 4-H24DF5024	24	2.865	2.835	3.15	.750	1
A 6T 4-H28SF5024	A 6T 4-H28DF5024	28	3.342	3.312	3.55	.750	1
A 6T 4-H30SF5024	A 6T 4-H30DF5024	30	3.581	3.551	3.78	.750	1
A 6T 4-H32SF5024	A 6T 4-H32DF5024	32	3.820	3.790	4.05	.750	1

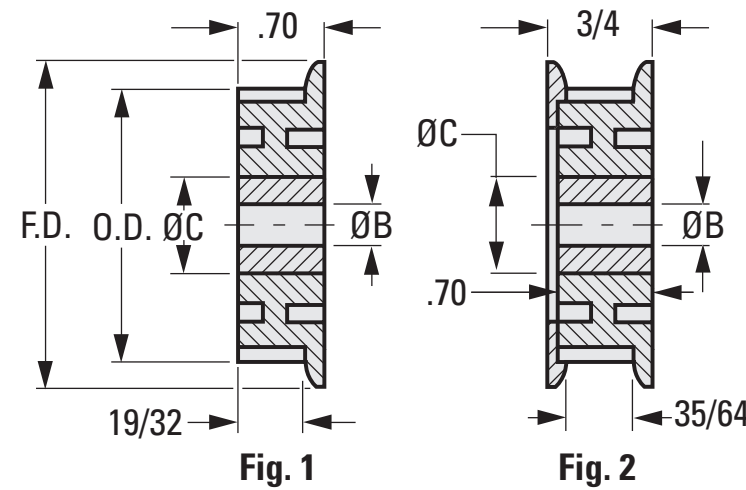

\*Only these pulleys require a 3/4 O.D. x 5/8 I.D. x .050 thick washer.  
 Pulleys with 10 to 12 grooves do not have webs.

### APPLICABLE SHAFTLOC® SLEEVE

Catalog Number	See Above	Pulley Bore (Ref.)	Shaftloc Bore +.001 -0.000	H Hex Size	Max. Torque Capacity* lbf in.
A 7Z37-030578	1	.625	.375	3/4	250
A 7Z37-040670	2	.750	.500	7/8	250

\*Based on mating components being degreased before assembly with Shaftloc® coupling.

#### SPECIFICATIONS:

1. A 3/4" O.D. x 5/8" I.D. x .05" thick washer, Catalog Number **A 7X 8-C20050** is supplied.
2. A 7/8" O.D. x 3/4" I.D. x .05" thick washer, Catalog Number **A 7X 8-C24050** is supplied.

Aluminum pulleys to mate with Shaftloc® are available upon request.

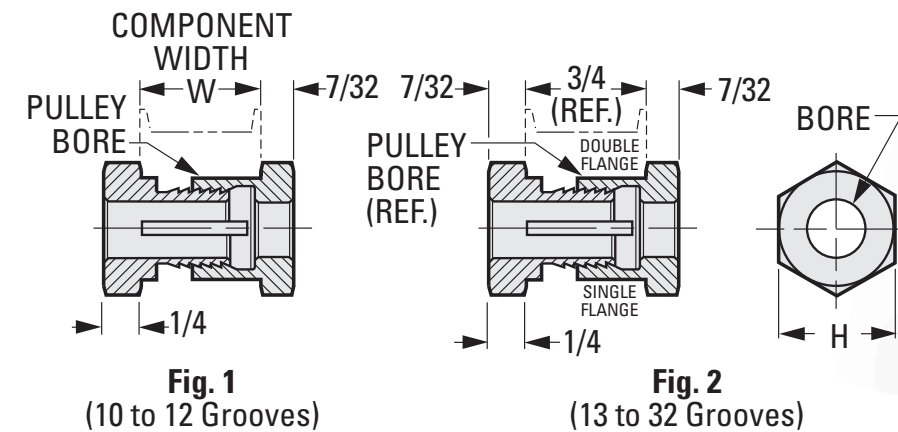

**MATERIAL:** 416 Stainless Steel

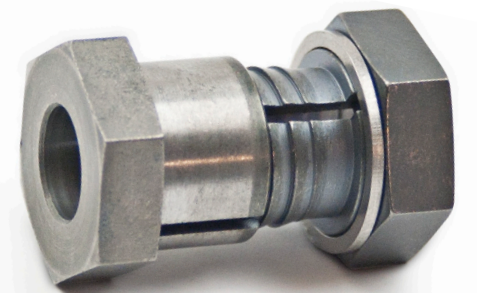

# SDPSI

PHONE: 516.328.3300 • FAX: 516.326.8827 • WWW.SDP-SI.COM

# HTD® PULLEYS FOR SHAFTLOC®

## 3 mm PITCH

**FOR 9 mm BELTS (.354 INCH)**  
 MOLDED WITH METAL INSERT  
 SINGLE OR DOUBLE FLANGE

**MATERIAL:** Pulleys: Nylon - Black, Fiberglass Reinforced  
 Insert: Steel, Overmolded

### INCH Components

Catalog Number		No. of Grooves	P.D.	O.D.	F.D.
Single Flange Fig. 1	Double Flange Fig. 2				
—	A 6T23-H30DF0920	30	1.128	1.098	1.25
A 6T23-H32SF0920	A 6T23-H32DF0920	32	1.203	1.173	1.32
A 6T23-H36SF0920	A 6T23-H36DF0920	36	1.353	1.323	1.47
A 6T23-H40SF0920	A 6T23-H40DF0920	40	1.504	1.474	1.62
A 6T23-H42SF0920	A 6T23-H42DF0920	42	1.579	1.549	1.70
A 6T23-H48SF0920	A 6T23-H48DF0920	48	1.805	1.775	1.92
A 6T23-H50SF0920	—	50	1.880	1.850	2.00
A 6T23-H60SF0920	—	60	2.256	2.226	2.37
A 6T23-H72SF0920	—	72	2.707	2.677	2.83

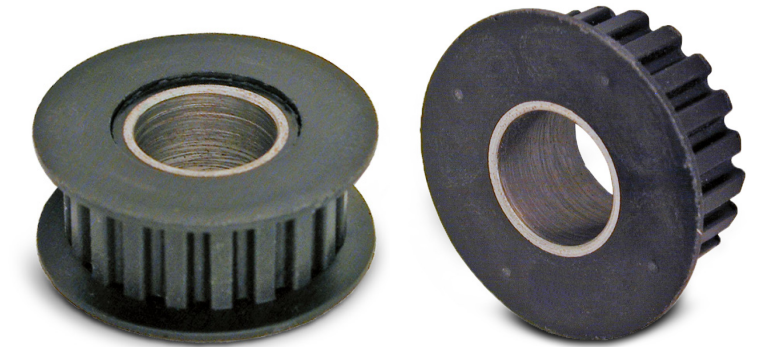
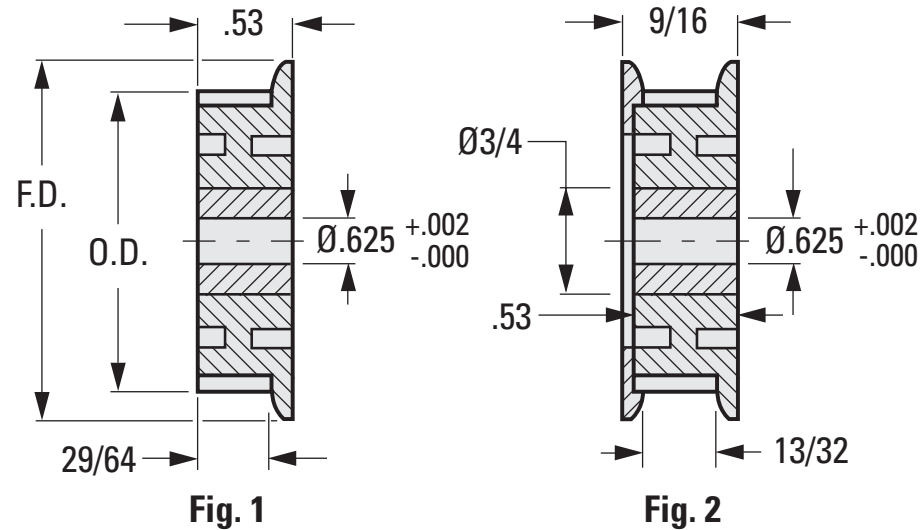

### APPLICABLE SHAFTLOC® SLEEVE

Catalog Number	Pulley Bore (Ref.)	Max. Torque Capacity* lbf in.
A 7Z37-030553	.625	250

**SPECIFICATIONS:**  
 A 3/4" O.D. x 5/8" I.D. x .05" thick washer, Catalog Number **A 7X 8-C20050** is supplied.

\*Based on mating components being degreased before assembly with Shaftloc® coupling.

Aluminum pulleys to mate with Shaftloc® are available upon request.

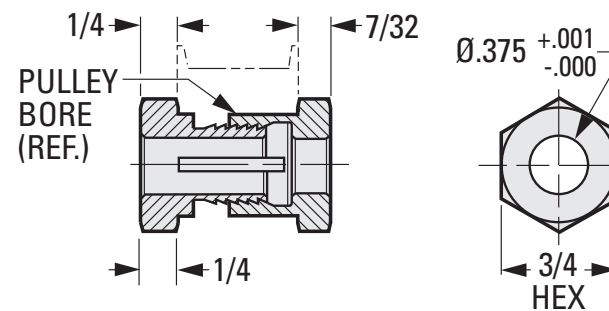

**MATERIAL:** 416 Stainless Steel

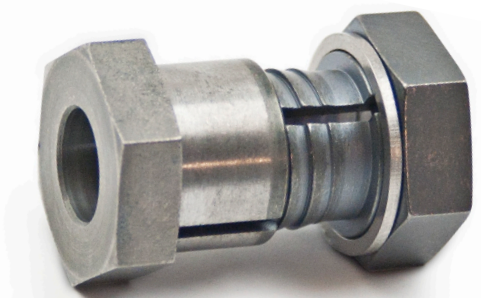

# HTD® PULLEYS FOR SHAFTLOC®

## 5 mm PITCH

**FOR 15 mm BELTS (.391 INCH)**  
 MOLDED WITH METAL INSERT  
 SINGLE OR DOUBLE FLANGE

**MATERIAL:** Pulleys: Nylon - Black, Fiberglass Reinforced  
 Insert: Steel, Overmolded

### INCH Components

Catalog Number		No. of Grooves	P.D.	O.D.	F.D.	B Dia. +.002 -.000	C Dia.
Single Flange Fig. 1	Double Flange Fig. 2						
A 6T25-H19SF1520	A 6T25-H19DF1520	19	1.191	1.146	1.31	.625	3/4
A 6T25-H20SF1524	A 6T25-H20DF1524	20	1.253	1.208	1.37	.750	1
A 6T25-H22SF1524	A 6T25-H22DF1524	22	1.379	1.334	1.50	.750	1
A 6T25-H24SF1524	A 6T25-H24DF1524	24	1.504	1.459	1.62	.750	1
A 6T25-H28SF1524	A 6T25-H28DF1524	28	1.754	1.709	1.87	.750	1
A 6T25-H30SF1524	A 6T25-H30DF1524	30	1.880	1.835	2.00	.750	1
A 6T25-H32SF1524	A 6T25-H32DF1524	32	2.005	1.960	2.12	.750	1
A 6T25-H36SF1524	A 6T25-H36DF1524	36	2.256	2.211	2.41	.750	1
A 6T25-H38SF1524	—	38	2.381	2.336	2.54	.750	1
A 6T25-H40SF1524	—	40	2.506	2.461	2.66	.750	1
A 6T25-H42SF1524	—	42	2.632	2.587	2.79	.750	1
A 6T25-H44SF1524	—	44	2.757	2.712	2.91	.750	1
A 6T25-H48SF1524	—	48	3.008	2.963	3.16	.750	1
A 6T25-H50SF1524	—	50	3.133	3.088	3.26	.750	1
A 6T25-H56SF1524	—	56	3.509	3.464	3.66	.750	1
A 6T25-H60SF1524	—	60	3.760	3.715	3.92	.750	1
A 6T25-H62SF1524	A 6T25-H62DF1524	62	3.885	3.840	4.03	.750	1
A 6T25-H64SF1524	—	64	4.010	3.965	4.16	.750	1
A 6T25-H72SF1524	—	72	4.511	4.466	4.66	.750	1
A 6T25-H80SF1524	—	80	5.013	4.968	5.16	.750	1

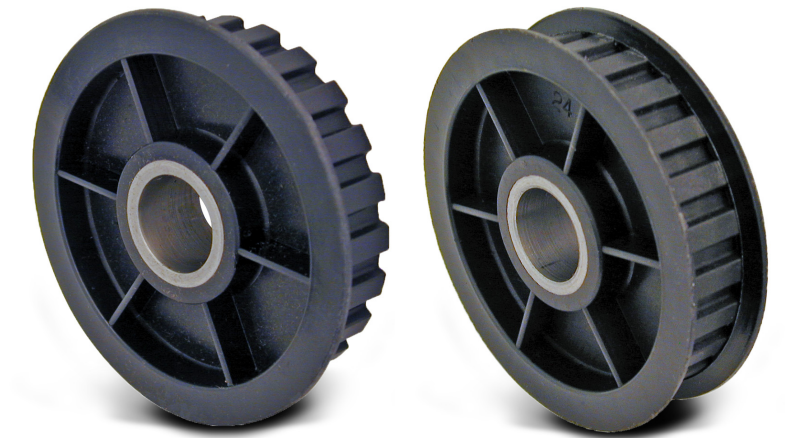
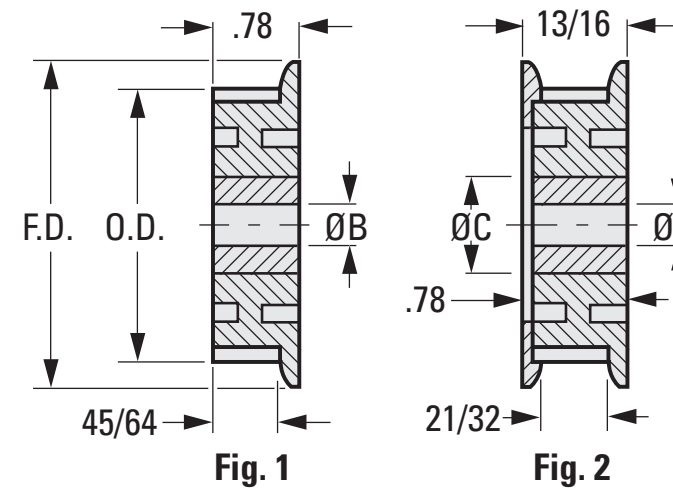

Pulley has steel insert with 1-1/2" O.D.  
 Pulleys with 19 to 24 grooves do not have webs.

### APPLICABLE SHAFTLOC® SLEEVE

Catalog Number	See Above	Pulley Bore (Ref.)	Shaftloc Bore +.001 -.000	H Hex Size	Max. Torque Capacity* lbf in.
A 7Z37-030578	1	.625	.375	3/4	250
A 7Z37-040670	2	.750	.500	7/8	250

\*Based on mating components being degreased before assembly with Shaftloc® coupling.

#### SPECIFICATIONS:

1. A 3/4" O.D. x 5/8" I.D. x .05" thick washer, Catalog Number **A 7X 8-C20050** is supplied.
2. A 7/8" O.D. x 3/4" I.D. x .05" thick washer, Catalog Number **A 7X 8-C24050** is supplied.

Aluminum pulleys to mate with Shaftloc® are available upon request.

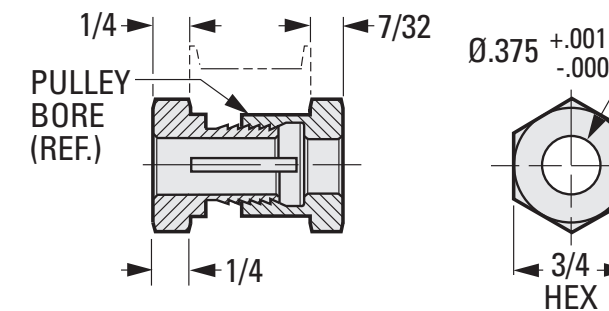

**MATERIAL:** 416 Stainless Steel

