

Dimensions

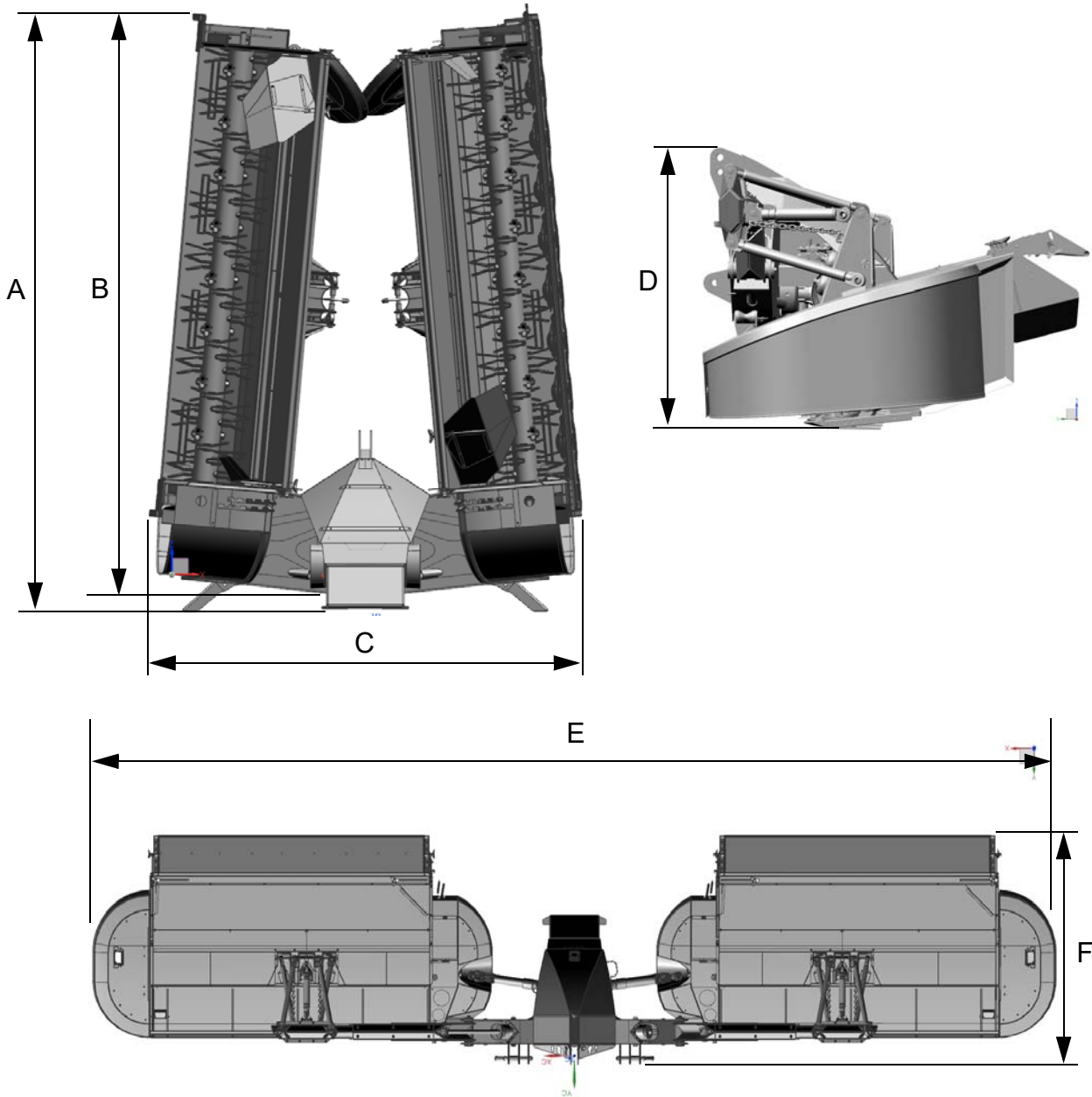

About the machine

Dim.	Unit	53100MT-MR
A	mm	3990
	inch	157
B	mm	3890
	inch	153
C	mm	2840
	inch	112
D	mm	1525
	inch	60
E	mm	10800
	inch	425
F	mm	2160
	inch	85

Belt equipment*

→ * »Optional equipment« page 196

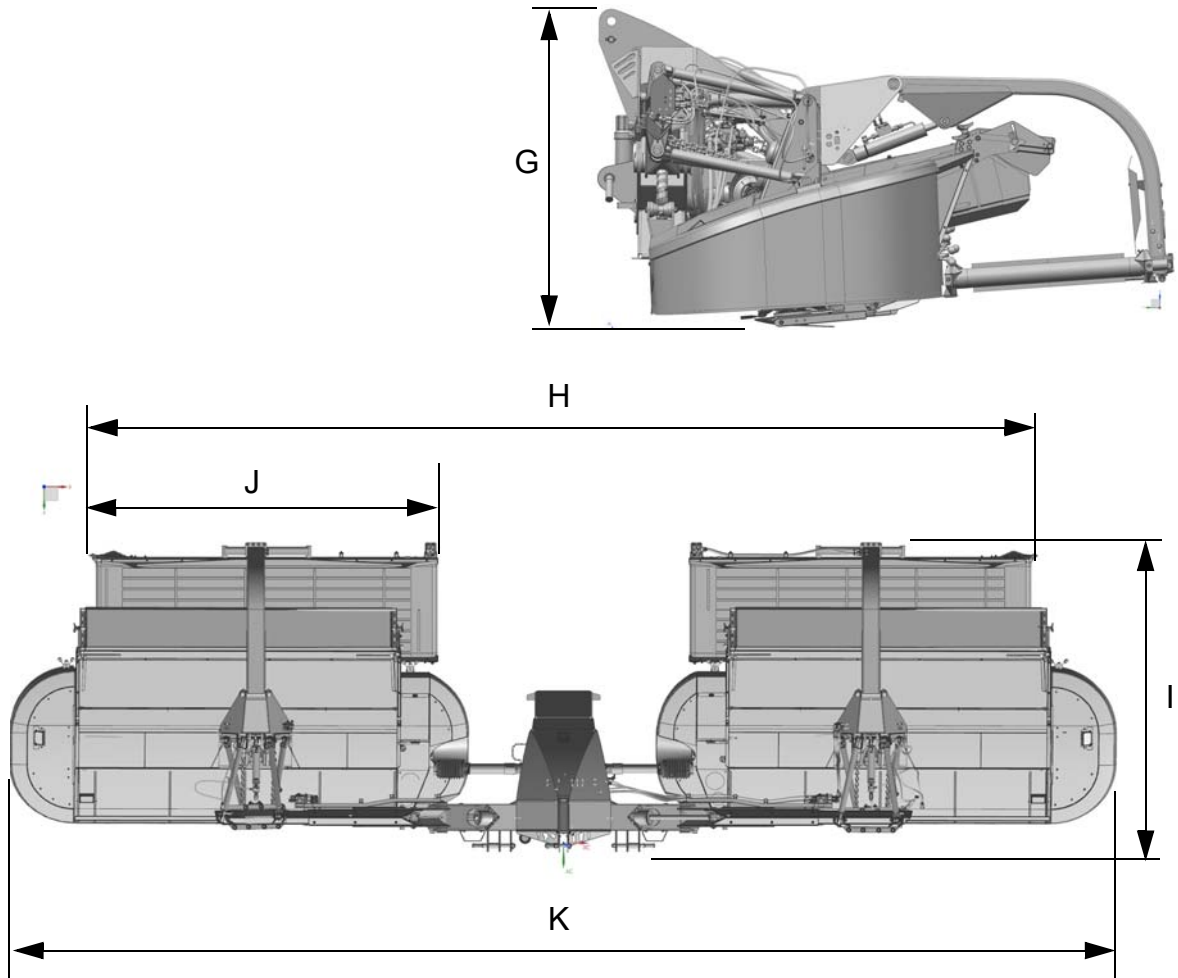

Dim.	Unit	53100MT-MR inc. belt equipment*
G	mm	1525
	inch	60
H	mm	8600
	inch	339
I	mm	2850
	inch	113
J	mm	3150
	inch	124
K	mm	10800
	inch	425

About the machine

Specifications

	Unit	53100MT	53100MR
Net weight	KG	3070	3190
	lb	6770	7035
Net weight inc. belt equipment ²	KG	3670	3790
	lb	8095	8360
PTO Power take off	rpm	1000	
Min. power requirement (PTO outlet)	kW	155 ¹	
	HP	210 ¹	
Min. power requirement (PTO outlet) inc. belt equipment ²	kW	175 ¹	
	HP	240 ¹	
Number of cutting discs	parts	18 (2x9)	
Number of knives	parts	36 (18x2)	
RPM, cutting discs	RPM	3000	
RPM, rotors	RPM	550 / 1000	
Stubble height	mm	35 - 50	
	inch	1,4 - 2	
Cutting width	m	10,2*	
	inch	394	
Hydraulic pressure, min. - max.	bar	180 - 220	
	psi	2610 - 3190	
Noise level	dB(A)	85	
Cutting speed	kilometres per hour	6 - 15	
	mph	4 - 9	

¹ Including the front cutting unit

² Extra equipment

→ »Optional equipment« Page 196

* Also see »Overlap« page 58