

### SYSTEM OVERVIEW

The Telesis® FQ10 is one laser in a family of maintenance-free, Q-switched, Ytterbium fiber lasers designed for marking applications. These lasers deliver a high power laser beam directly to the marking head via a flexible, metal-sheathed fiber cable. The fiber based optical design and rugged mechanical design allows the Telesis FQ10 to operate in an industrial environment where shock, vibration, and dust are a concern.

The FQ10 unique design allows for a remote beam delivery system. The galvanometer package is attached to a fiber-optic delivery system from a remote laser engine. This allows the overall package to be very small and modular.

The FQ10 fiber laser offers these advantages:

- Standard 115/230 VAC operation
- Over 100,000 hours of reliable, maintenance-free performance
- Compact size and modular construction
- Output laser beam delivery via a fiber optic cable
- Exceptional beam quality and stable output power
- Active AO Q-switching
- Display for monitoring actual laser power
- Display for monitoring hours of operation
- Sealed head to prevent dust contamination in optical chamber
- Visible red diode for aiming and dry run operations
- Air cooled
- DoD-compliant Unique Identification (UID) marking

### SYSTEM CONFIGURATION

The basic laser system consists of the following components. The modular design allows for major components to be easily replaced and returned to Telesis if required.

**Laser Controller** – contains the laser source unit, circuit boards, electrical components, and the operator console

**Fiber Optic Cable Assembly** – with optical isolator

**Laser Marking Head** – includes the shutter assembly, visible red aiming diode, galvanometer assembly, and flat-field lens

**Software** – Merlin®II LS Laser Marking Software

**System Computer** – supplied by Telesis or by customer

# FQ10 Laser Marking System

---

## SYSTEM SPECIFICATIONS

Compliance .....	CDRH, CE, CSA, UL
Laser Type.....	Q-switched Ytterbium fiber
Wavelength .....	1060 nanometers ( $\pm 10$ nm)
Long Term Output	
Power Drift.....	$< \pm 5\%$
Laser Diode MTBF.....	100,000 hours
Power Requirements.....	95 to 250 VAC, 50/60 Hz
System Power (total).....	$< 200$ W
Maximum Supply Voltage ....	264 VAC
Supply Voltage Fluctuation ....	$< \pm 10\%$ with clean ground
Operational Temp. ....	18° to 35°C (65° to 95°F)
Recommended Temp.....	20° to 25°C (68° to 77°F)
Ambient Relative Humidity....	10% to 85% non-condensing

## SYSTEM OPTIONS

- Desktop computer or notebook computer with powered cardbus-to-PCI expansion enclosure
- Remote pushbutton station (start/abort)
- Externally-mounted focus-finder diode
- I/O options (see *Remote Communications* for details):
  - TTL via PCI-DIO24 Board
  - Opto-isolated via Merlin DCIO Module
  - Telesis two-axis controller
- Programmable tool post for vertical (z-axis) adjustment (requires two-axis controller)
- Rotary drive fixture for rotational (theta-axis) adjustment (requires two-axis controller)
- Workstation / work area enclosure
- Fume extraction systems

## SYSTEM SETUP

The following procedures are listed for reference only to provide a general overview of the installation process. Refer to the *FQ10 Installation & Maintenance Manual* for complete installation details.

**Do not connect any power cable to power source until all system connections are made.**

1. Equipment should remain powered down and in OFF position until mounting is complete.
2. Place the laser controller, system computer, monitor, and keyboard in the desired location. Locate controller as close as practical to laser marking head – typically within 5m (16 feet).
3. Ensure sufficient clearance exists on all sides of the laser controller to allow for proper air circulation and to permit proper installation of applicable cables. Refer to the *Model 6/FQ Laser Controller Dimensions* drawing.
4. Place the laser marking head on a suitable mounting surface.
5. Ensure sufficient clearance exists on all sides of the laser marking head to allow for proper air circulation and to permit proper installation of applicable cables.
6. Secure laser marking head to mounting fixture with four M6-1.0 bolts and lock washers using the four factory-tapped mounting holes provided in the marking head base plate.
7. Select proper fuse arrangement for the laser controller. Refer to the *FQ10 Installation & Maintenance Manual*. Connect power cable controller.
8. Connect remaining cables, as applicable.
9. Refer to *FQ10 Operation Supplement* for proper startup procedure. Refer to the *Merlin II LS Operating Instructions* for complete information on using the system software.

# FQ10 Laser Marking System

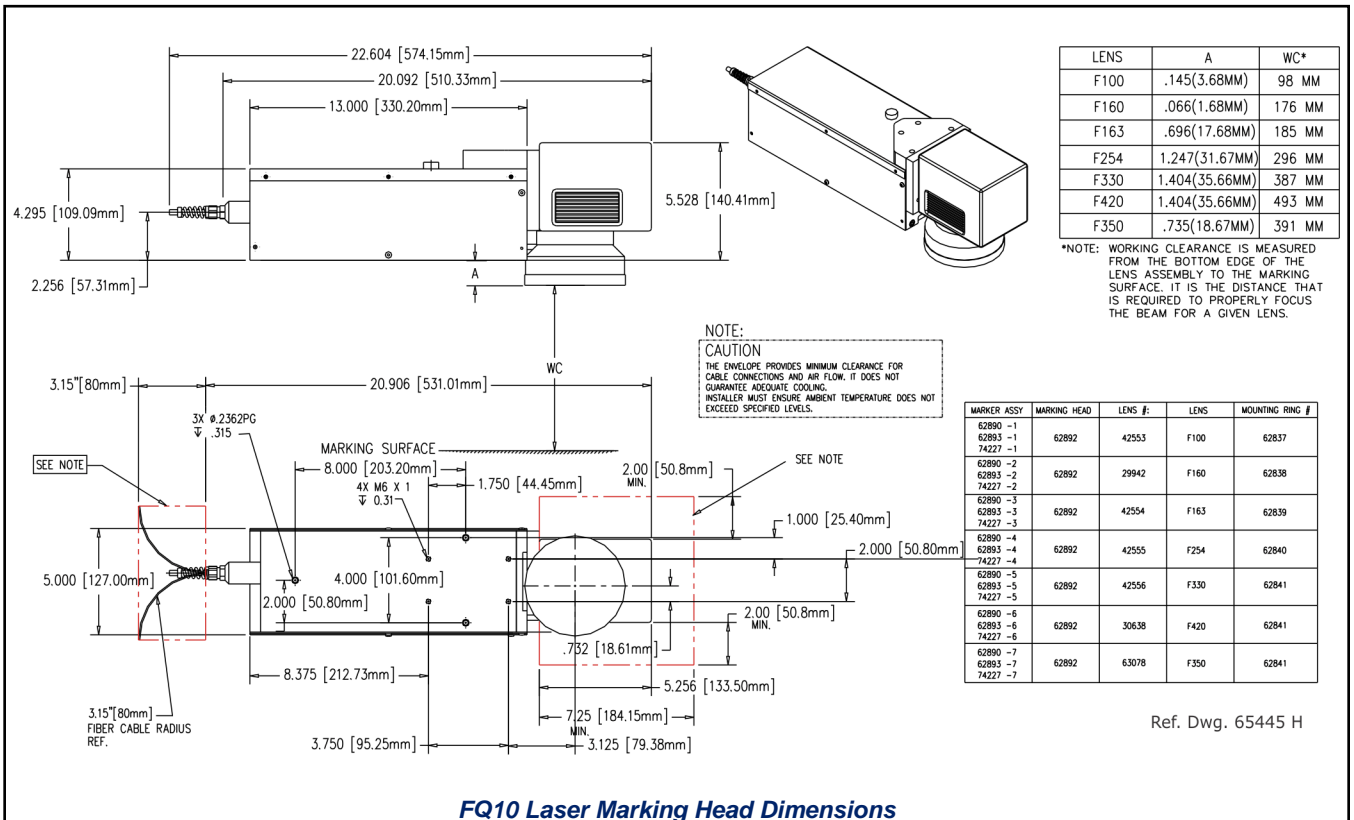

**FQ10 Laser Marking Head Dimensions**

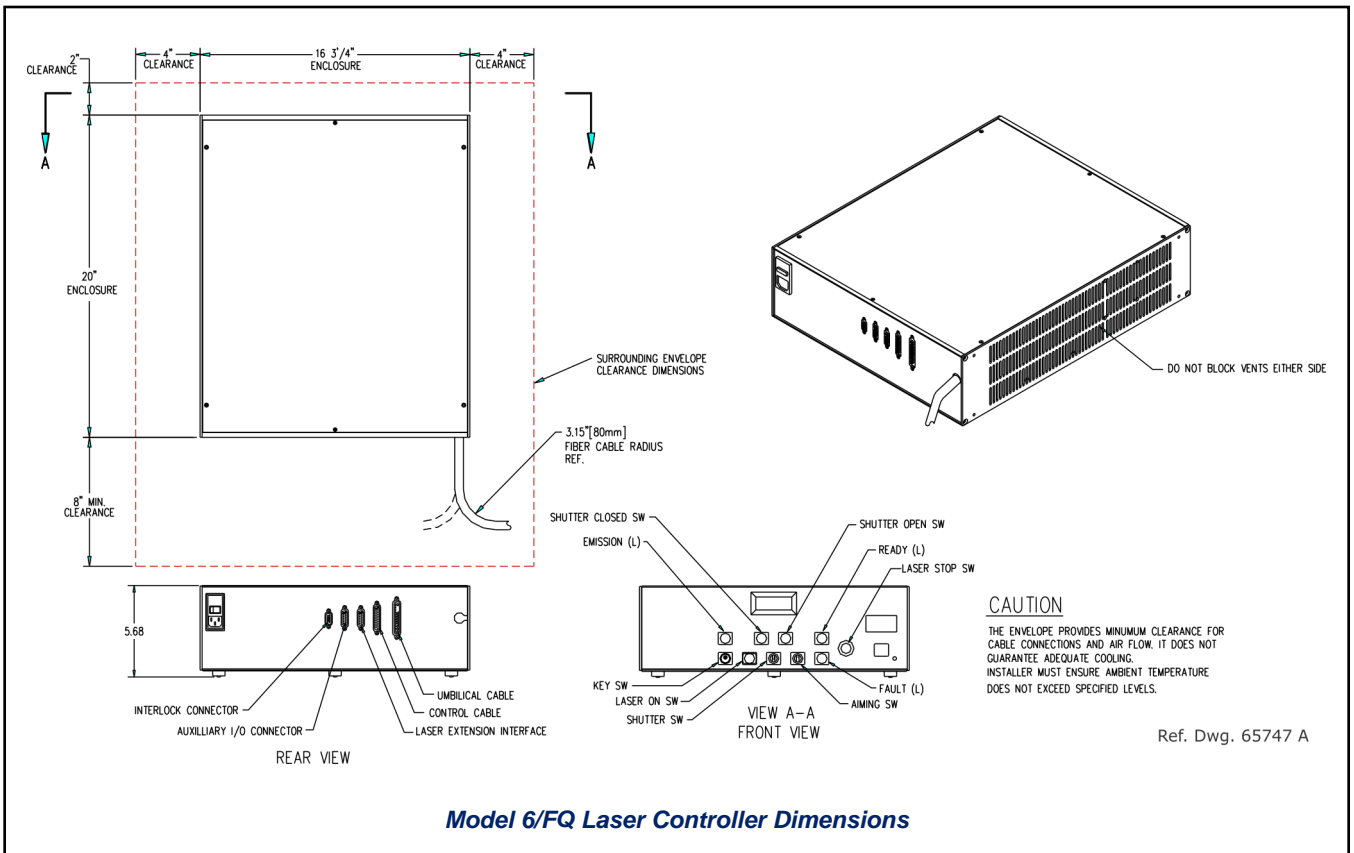

**Model 6/FQ Laser Controller Dimensions**

# FQ10 Laser Marking System

## FQ10 LASER MARKING HEAD LABELS

The following illustration shows the labels and their locations on the FQ10 laser marking head. Please familiarize yourself with the laser labels and their locations prior to operating the laser marking system.

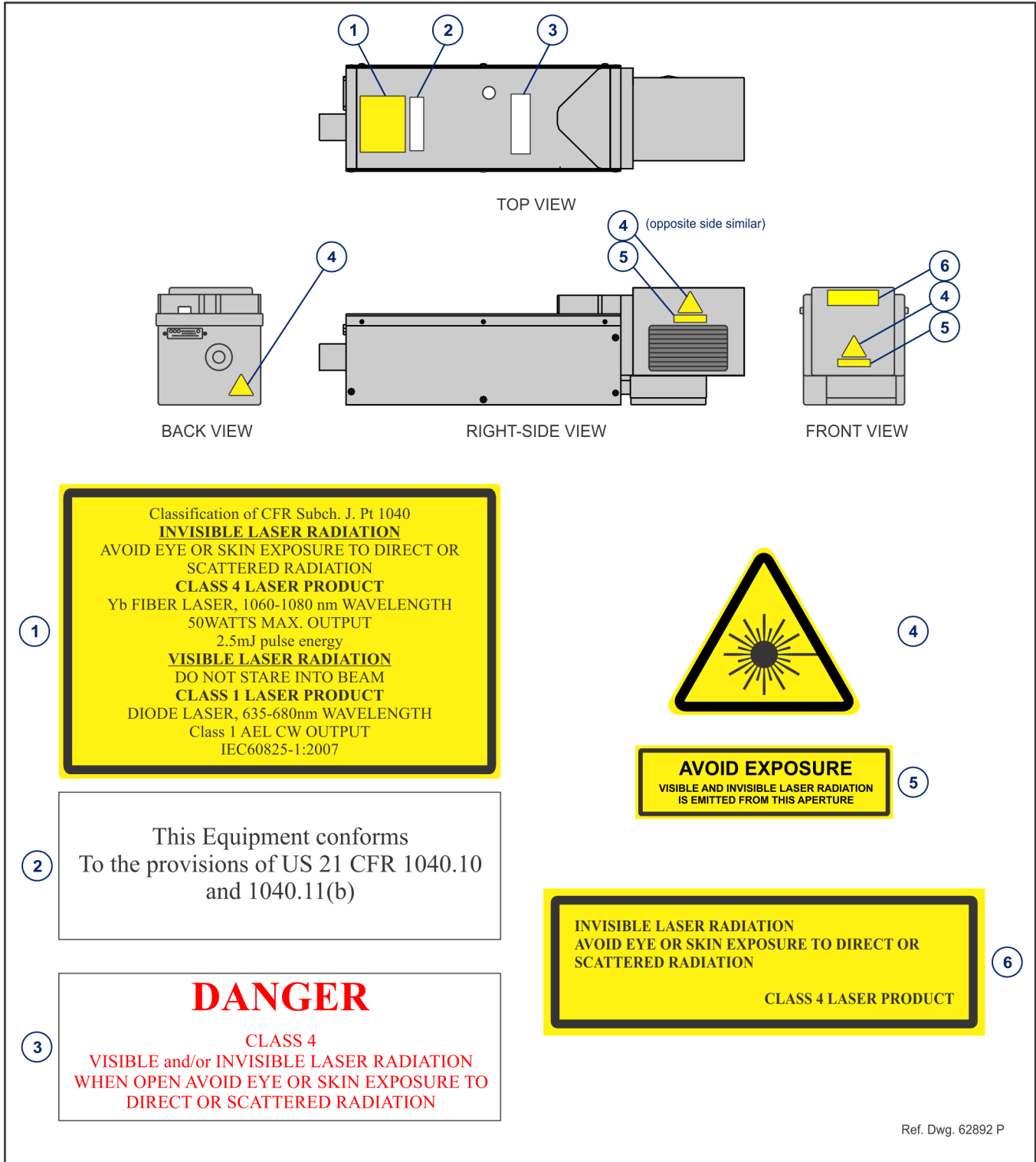

## MODEL 6/FQ LASER CONTROLLER SAFETY LABELS

The following illustration shows the labels and their locations on the Model 6/FQ laser controller. Please familiarize yourself with the laser labels and their locations prior to operating the laser marking system.

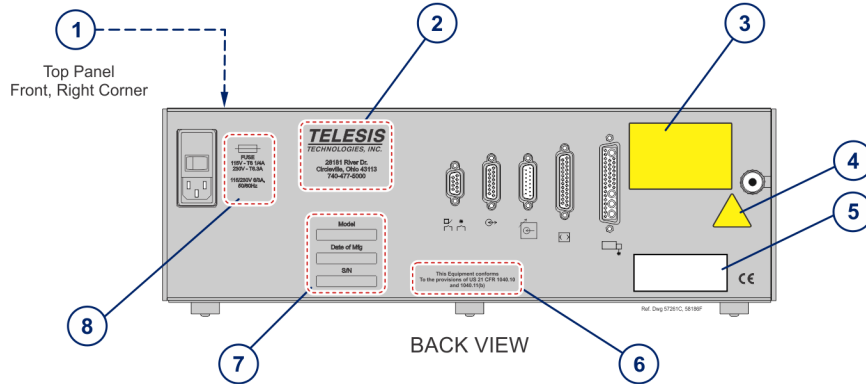

CAUTION: RISK OF ELECTRIC SHOCK. DO NOT OPEN  
ATTENTION: RISQUE DE CHOC ELECTRIQUE. NE PAS OUVRIR.

SEE INSTALLATION INSTRUCTIONS BEFORE CONNECTING TO THE SUPPLY.  
VOIR LA NOTICE D'INSTALLATION AVANT DE RACCORDER AU RESEAU.

**TELESIS**  
TECHNOLOGIES, INC.

28181 River Dr.  
Circleville, Ohio 43113  
740-477-5000

Complies With  
UL 61010-1  
CSA C22.2 No. 61010-1  
E112723

Classification of CRF Subch. J. Pt 1040  
**INVISIBLE LASER RADIATION**  
AVOID EYE OR SKIN EXPOSURE TO DIRECT OR  
SCATTERED RADIATION  
**CLASS 4 LASER PRODUCT**  
Yb FIBER LASER, 1060-1080 nm WAVELENGTH  
50WATTS MAX. OUTPUT  
2.5mJ pulse energy  
IEC60825-1:2007

This Equipment conforms  
to the provisions of US 21 CFR 1040.10  
and 1040.11(b)

Model

Date of Mfg

S/N

FUSE  
115V - T6 1/4A  
230V - T6.3A

115/230V 6/3A,  
50/60Hz



Ref. Dwgs L57261 C & L68951 - & L63592

# FQ10 Laser Marking System

## FQ10 LASER MARKING HEAD

The laser marking head includes the shutter assembly, visible red aiming diode, circuit board, galvanometer assembly, and the flat-field lens. The beam collimator and isolator (at the end of the fiber optic cable) are enclosed within the laser marking head.

### FQ10 Laser Marking Head Specifications

Dimensions (L x W) .....	574.15 x 127.00 mm (22.604 x 5.000 in.)
Dimensions (H).....	Dependent on lens selection: F100 lens: 143.91 mm (5.666 in.) F160 lens: 141.91 mm (5.587 in.) F163 lens: 157.91 mm (6.217 in.) F254 lens: 171.90 mm (6.768 in.) F330 lens: 175.89 mm (6.925 in.) F350 lens: 158.90 mm (6.256 in.) F420 lens: 175.89 mm (6.925 in.)
Surrounding Envelope .....	see <i>FQ10 Laser Marking Head Dimensions</i> drawing
Electrical Power .....	60W (approximate)
Mounting Weight .....	approx. 6.82 Kg (15 lbs.)
Mounting .....	four factory-tapped M6-1.00 holes
Positioning .....	visible (red) aiming diode
Field Resolution .....	16 bit (65535 data points)
Galvanometer	
Repeatability.....	< 22 micro radian
Marking Field Size .....	lens-dependent, see chart
Fiber Optic Cable.....	5 m (16.4 ft.)
Laser Marking Head Cable....	5 m (16.4 ft.), detachable
Laser Extension Cable .....	3.05 m (10.0 ft.), detachable

### Visible Red Aiming Diode

The laser marking head produces a visible red diode that may be viewed on the work surface without the need for protective safety goggles. This provides a safe and convenient aid for laser setup and part programming. Since the red beam is located *after* the shutter, the aiming diode may be used with the shutter opened or closed. Additionally, the visible red beam may be used with the lasing beam during the marking cycle. **Note that protective eyewear must always be worn when the laser is in operation.**

### Marking Field Size

The size of the marking field is dependent on type of lens installed on the laser marking head. See *Flat-Field Lens*.

### Marking Depth

Simple laser parameters can be operator programmed to create depths ranging from simple surface discoloration, shallow laser etching, or deep laser engraving. Marking depth is dependent on several factors including material, lens type selected, and laser marking parameters. Please contact Telesis for the proper setting for your specific application.

### Flat-Field Lens

The flat-field lens is key to the marking performance of the system. This is the final coated optical lens that the beam will pass through before it strikes the marking target. This lens is called a flat field lens because when the beam is focused, the focus lies in a plane perpendicular to the optical axis of the lens. To protect the final objective lens from dust and debris, a clear protective cover is inserted between the work area and the lens.

The following chart outlines the available lenses, the resulting image field (marking window) provided by the lens, and the working clearance (in millimeters and inches) to properly focus the laser for marking.

Lens	Image Field		Working Clearance	
	(mm)	(in.)	(mm)	(in.)
100 mm	65 x 65	2.56 x 2.56	98	3.86
160 mm	90 x 90	3.54 x 3.54	176	6.93
163 mm	110 x 110	4.33 x 4.33	185	7.28
254 mm	175 x 175	6.89 x 6.89	296	11.65
330 mm	230 x 230	9.06 x 9.06	387	15.24
350 mm	250 x 250	9.84 x 9.84	391	15.39
420 mm	290 x 290	11.42 x 11.42	493	19.41

## MODEL 6/FQ LASER CONTROLLER

The laser controller houses the laser source unit, power supplies, circuit boards, programmable logic controller, control relay, cooling fan, a 115/230VAC IEC320 connector, and a front panel control module.

The laser source unit generates the lasing beam. Engineered for the greatest reliability and for ease of maintenance, the laser source is an easily replaceable sealed module with an expected MTBF of 100,000 operating hours.

### Model 6/FQ Laser Controller Specifications

Dimensions (W x H x D) .....	425.5 x 144.3 x 508.0 mm 16.75 x 5.68 x 20.00 in.
Surrounding Envelope.....	see <i>Model 6/FQ Laser Controller Dimensions</i> drawing
Weight.....	approx. 15 Kg (33 lbs.)
Cooling.....	air cooled, fan

### Operator Control Panel

The front panel control module includes the system key switch, laser off push button, manual safety shutter control, function indicators, an LCD panel to monitor elapsed emission time, and an LED panel to monitor laser power.

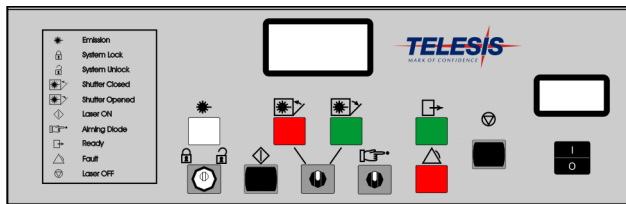

**Model 6/FQ Laser Controller**

### Fiber Optic Cable Assembly

The lasing beam is delivered to the laser marking head from the laser controller through a fiber optic cable. One end of the fiber optic cable is permanently attached to the laser source unit inside the laser controller. The opposite end of the cable includes a beam collimator and isolator that is enclosed within the laser marking head assembly. The standard fiber optic cable for the FQ10 is 5 m (16.4 ft.) long.

### Optical Isolator

To prevent back reflections an *optical isolator* is used in all standard FQ10 Laser Marking Systems. Installed on the laser marking head end of the fiber optic cable, the isolator functions as a one way check valve allowing laser light to exit the laser but not return to the laser's most sensitive optical components.

# FQ10 Laser Marking System

## SYSTEM COMPUTER

The laser system requires an IBM-compatible computer for running the Merlin II LS Laser Marking Software. The system computer may be a desktop or a notebook computer and may be supplied by Telesis or by the customer.

All system computers supplied by Telesis have the laser/galvo controller board and the Merlin II LS software installed prior to shipment so the entire assembly is tested as a laser marking system. Warranties for the computer, keyboard, monitor, and peripherals default to the original equipment manufacturer.

If the system computer is supplied by anyone other than Telesis it must use the following software:

Operating System .....	Windows® 2000, XP, Vista® (Business), 7 (professional) or 8 (Professional)
Operator Interface.....	Telesis Merlin II LS Laser Marking Software

Additionally the system computer must, at a minimum, meet the following specifications:

Processor.....	Pentium® III with RAM as recommended per operating system
Hard Drive .....	2 GB Hard Disk Drive
External Drives .....	CD-ROM Drive
Comm Ports .....	One available RS-232 Serial Port, Two available USB Ports, Two available Ethernet Ports, Two available full-height PCI Slots*
Circuit Cards.....	Laser/Galvo Controller Board, Video Board
Peripherals .....	SVGA Color Monitor, Mouse, Keyboard

\* If the system computer is a notebook, expansion must be used to provide the PCI slots.

## SYSTEM SOFTWARE

The powerful Telesis Merlin II LS Laser Marking Software is a Windows® based software package that comes with the standard laser marking system. It is a graphical user interface that makes marking pattern design quick and easy. The WYSIWYG (what-you-see-is-what-you-get) interface provides a to-scale image of the pattern as it is created. Just “click and drag” for immediate adjustment to field size, location, or orientation.

The Merlin II LS software includes tools to create and edit text at any angle, arc text, rectangles, circles, ellipses, and lines. Multiple fields may be grouped and saved as a block to form a logo. Existing DXF files can also be imported for marking. Non-printable fields can be created to clearly display a graphical representation of the part being marked.

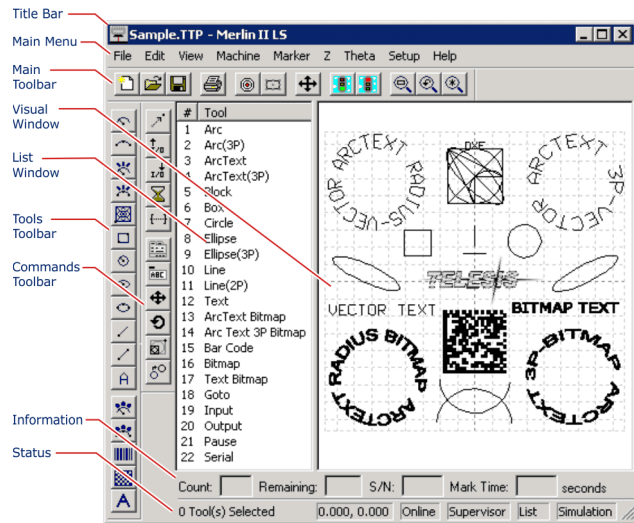

**Merlin II LS User Interface**

## Merlin II LS Laser Marking Software Specifications

Font Generation .....	True Type Fonts
Barcodes and Matrix .....	2D Data Matrix, PDF417, BC 39, Interleaved 2 of 5, UPCA/UPCE, BC 128, Maxi Code, Code 93, QR Code and others
Graphic Formats.....	Raster and Vector: BMP, GIF, JPG, WMF, EMF, DXF, CUR, ICO
Serialization .....	Automatic and Manual Input Host Interface Capable
Linear Marking .....	Scalable w/ Letter Spacing Control
Arc Text Marking.....	Scalable and Adjustable
Drawing Tools .....	Line, Rectangle, Circle, Ellipse



## Remote Communications

The communication capability of the laser marking software allows you to control the laser from remote I/O devices. Remote communications can be performed by connecting to a Host computer, an optional I/O kit, or an optional two-axis Auxiliary Controller.

The rear panel of the controller also provides a connector to monitor output signals that report the status of the shutter, laser emission, and fault conditions.

**Host Communications.** Remote communications may be executed from a host computer using RS-232 or Ethernet (TCP/IP) connections to the system computer (i.e., the PC running the Telesis laser marking software). The software provides parameters to define the data transmitted to and from the host. For more information on using and configuring these parameters, refer to the *Merlin II LS Operating Instructions*.

**I/O Kits.** Telesis offers optional I/O kits that provide up to 12 additional, programmable I/O signals (6 inputs and 6 outputs). All kits provide an I/O card, pre-installed SIPs resistor packs, and software driver CD. For details on connecting and using the additional I/O signals, refer to the *Installation Supplement* provided in each of the kits.

- **Kit 53920** <sup>(1)</sup> provides a PCI-DIO24 card.
- **Kit 53928** <sup>(2)</sup> provides a PCI-DIO24 card, the Merlin I/O Interface Module, and two cable assemblies.
- **Kit 74445** <sup>(1)</sup> provides a PCIe-DIO24 card (PCIe x1).
- **Kit 53928** <sup>(2)</sup> provides a PCIe-DIO24 card (PCIe x1), the Merlin I/O Interface Module, and two cable assemblies.

- 1) *This kit does not provide opto-isolated signals. Telesis does not endorse direct connection of I/O signals to the I/O board. Direct connections to high current/high voltage devices will damage the board.*
- 2) *When using the Merlin I/O Interface Module in this kit, additional I/O racks or opto-isolated board assemblies are not required.*

**Two-axis Controller.** Telesis offers an optional two-axis controller for all laser systems that use the Merlin II LS Laser Marking Software. The auxiliary controller provides an interface for connecting a Z-axis tool post and/or a Theta-axis rotary drive unit. An optional board allows connection of two additional linear axes. For installation details, refer to the *Auxiliary Controller Installation & Maintenance Manual* supplied with the two-axis controller.

## Communications Protocol

Two types of host interface are supported (RS-232 or TCP/IP) and two communication protocols are provided through the Merlin II LS laser marking software: Programmable and Extended.

**Programmable Protocol.** Programmable protocol provides one-way (receive only) communication with no error checking or acknowledgment of the transmitted data. You may use Programmable protocol to extract a continuous portion of a message string to print. This can be used with a host computer or a bar code scanner. Note that XON/XOFF Protocol applies even when Programmable Protocol is selected.

The Programmable Protocol Message Type identifies the type of message sent from the host. It determines how the marker uses the data it extracts from the host message string when Programmable Protocol is used.

- 49 Message type 49** (ASCII 1) overwrites the content of the first text-based field in the pattern with the data extracted from the host message. Note that if the field contains message flags, they will be overwritten, not updated.
- 65 Message type 65** (ASCII A) updates the Offset Angle parameter with the data extracted from the host message. Syntax for the transmitted string is  $\pm n$  where  $\pm$  is a positive or negative sign and  $n$  is an integer that represents the offset angle for the marking window.
- 72 Message type 72** (ASCII H) updates the Offset X/Y parameters with the data extracted from the host message. Syntax for the transmitted string is  $\pm X.X, \pm Y.Y$  where  $\pm$  is a positive or negative sign,  $X.X$  represents the X-axis offset distance, and  $Y.Y$  represents the Y-axis offset distance.
- 80 Message type 80** (ASCII P) indicates the data extracted from the host message is the name of the pattern to be loaded.
- 81 Message type 81** (ASCII Q) updates the text in the first query text buffer (buffer 0) with the data extracted from the host message.
- 86 Message type 86** (ASCII uppercase V) updates the text in the first variable text field in the pattern with the data extracted from the host message.
- 118 Message type 118** (ASCII lowercase v) updates the first text field encountered in the pattern that contains a variable text flag that matches the specified string length.
- 0 Message type 0** (zero) indicates that host will provide message type, field number (if applicable), and data;. This delegates message type selection to the host on message-by-message basis. The host message must use the format:

**Tnn<string>**

where:

- T = the message type (1, A, H, P, Q, V, or v)
- nn = the two-digit field number or query text buffer where data will be placed.

**Note:** Not used with Message Types A, H, P.

<string>= the pattern name to load (Message Type P).  
or  
the data to be inserted into the field or the query text buffer, as applicable (Message Types 1, Q, V, or v).

# FQ10 Laser Marking System

---

## Communications Protocol (continued)

**Extended Protocol.** Extended protocol provides two-way communication with error checking and transmission acknowledgment. It is designed to provide secure communications with an intelligent host device using pre-defined message formats and response formats where serial communication is a vital part of the marking operation.

All communications are carried out in a parent/child relationship with the host being the parent. Only the host has the ability to initiate communications. The following describes the Extended Protocol message format as sent from the host to the Merlin II LS software.

### SOH TYPE [##] STX [DATA] ETX BCC CR

where:

- SOH** ASCII Start of Header character (001H). The system ignores all characters received prior to the SOH.
- TYPE** A single, printable ASCII character that defines the meaning (type) and content of the message downloaded from the host, where:
- 1** **Message Type 1** provides data to a text string in the pattern or polls the pattern for data. See [DATA] for details.
  - A** **Message Type A** provides data to the system Offset Angle parameter for the marking window or polls the system for data. See [DATA] for details.
  - E** **Message Type E** allows the host to take the machine offline. It also provides the option of displaying an error message box with the provided data string. See [DATA] for details.
  - G** **Message Type G** initiates a print cycle.
  - H** **Message Type H** provides data to the system X/Y Offset parameters or polls the system for data. See [DATA] for details.
  - I** **Message Type I** polls the system for the I/O status.
  - O** **Message Type O** places the marker online. This allows a host computer to reset. For example, this may be used to recover from a power outage when the marker is unattended.
  - P** **Message Type P** loads a pattern or polls the system for the current pattern name. See [DATA] for details.
  - Q** **Message Type Q** provides data to the system query text buffer or polls the system for data. See [DATA] for details.
  - S** **Message Type S** polls the system for the machine status. The machine status is returned to the host in an eight-character hexadecimal mask.
  - V** **Message Type V** provides data to a variable text string in the pattern or polls the pattern for data. See [DATA] for details.
- [##] Optional two-digit ASCII number that specifies the Station ID of the system in multi-drop network applications. The ID may range from 00-31. Note that "00" is reserved for applications where only one controller is used. In such applications, this field may be eliminated and "00" will be assumed.

- STX** ASCII Start of Text Character (002H).
- [DATA]** Character string that may be required for certain message types (e.g., Type 1, A, E, H, P, Q, or V).

Typically, data is sent in the format:

**nn<string>**

where:

**nn** = the two-digit field number or query text buffer where data will be placed. (Message Types 1, Q, or V).

**<string>** = the data to be inserted into the field or the query text buffer, as applicable (Message Types 1, Q, or V).

or  
the pattern name to load (Message Type P).

or  
the value of the X/Y Offset (Message Type H).

or  
the value of the Offset Angle (Message Type A).

- ETX** ASCII end of text character (003H).
- BCC** Optional Block Check Code that is generated and sent to improve link reliability by providing fault detection. The BCC is calculated by taking an eight bit addition of the TYPE and DATA TEXT characters and transmitting them as a three digit ASCII decimal number in the range from 000 to 255. If the sum is greater than 255, the most significant bit overflows and is discarded.
- CR** ASCII Carriage Return Character (00DH).

## TRADEMARKS

**Telesis** and **Merlin** are registered trademarks of Telesis Technologies, Inc. in the United States and/or other countries.

**Pentium** is a registered trademark of Intel Corporation in the United States and other countries.

**Windows** and **Vista** are registered trademarks of Microsoft Corporation in the United States and other countries.