

IMPACT 80 HEBELIFTE & HEBEZEUGE

- ZEICHNUNGEN & MASSE

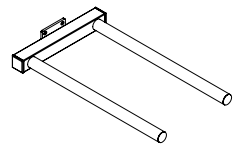
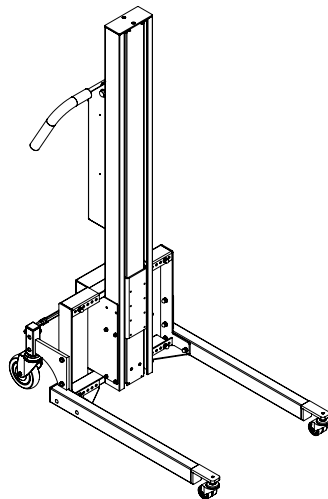
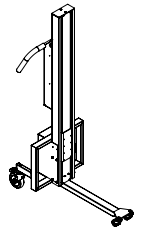
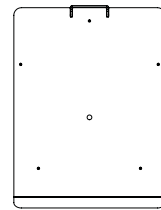
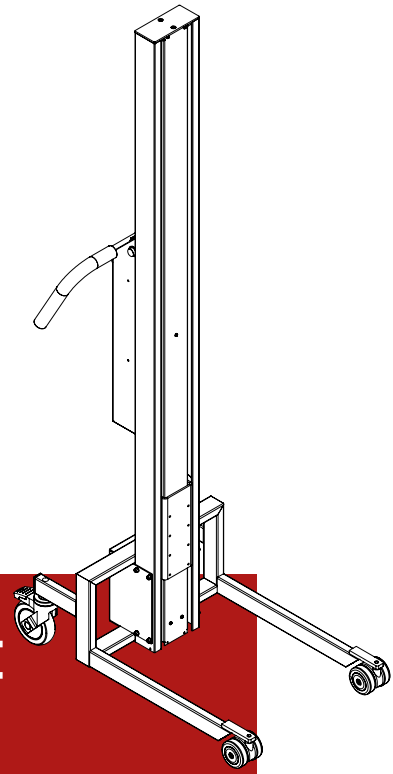

HOVMAND
LIFTING & MOVING TECHNOLOGY

IMPACT 80

2 MASTHÖHEN UND 21 BEINE/RÄDER OPTIONEN

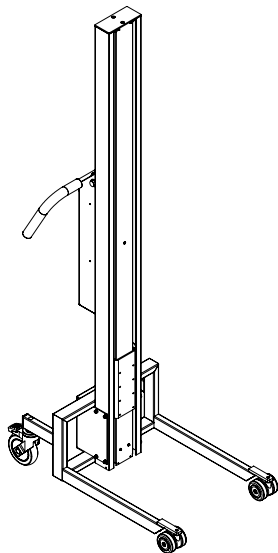

80 L/M standard beine

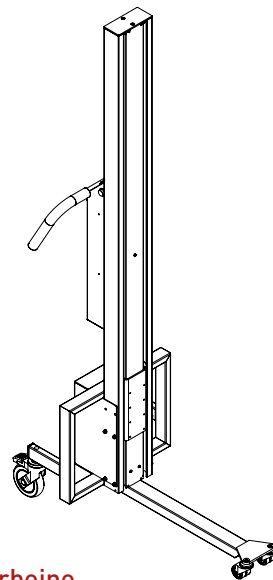

80 L/M Centerbeine

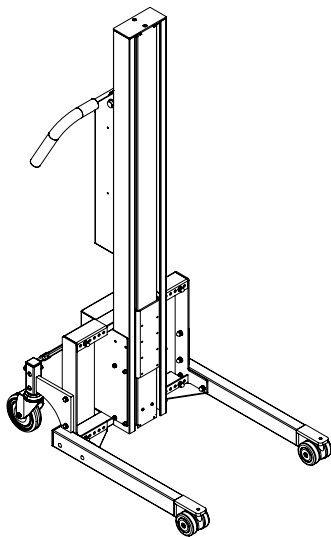

80 L/M FC - Flexbeine Typ 1

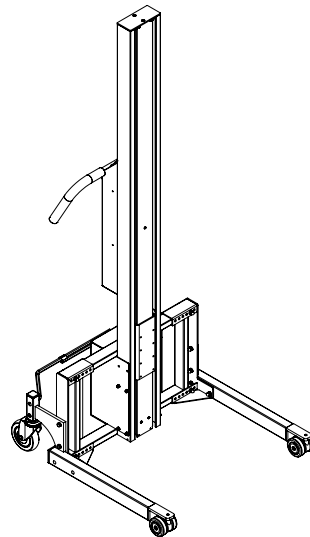

80 L/M FC - Flexbeine Typ 2

IMPACT 80

HEBELIFTE - ZEICHNUNGEN & MASSE

- Alles masse in mm

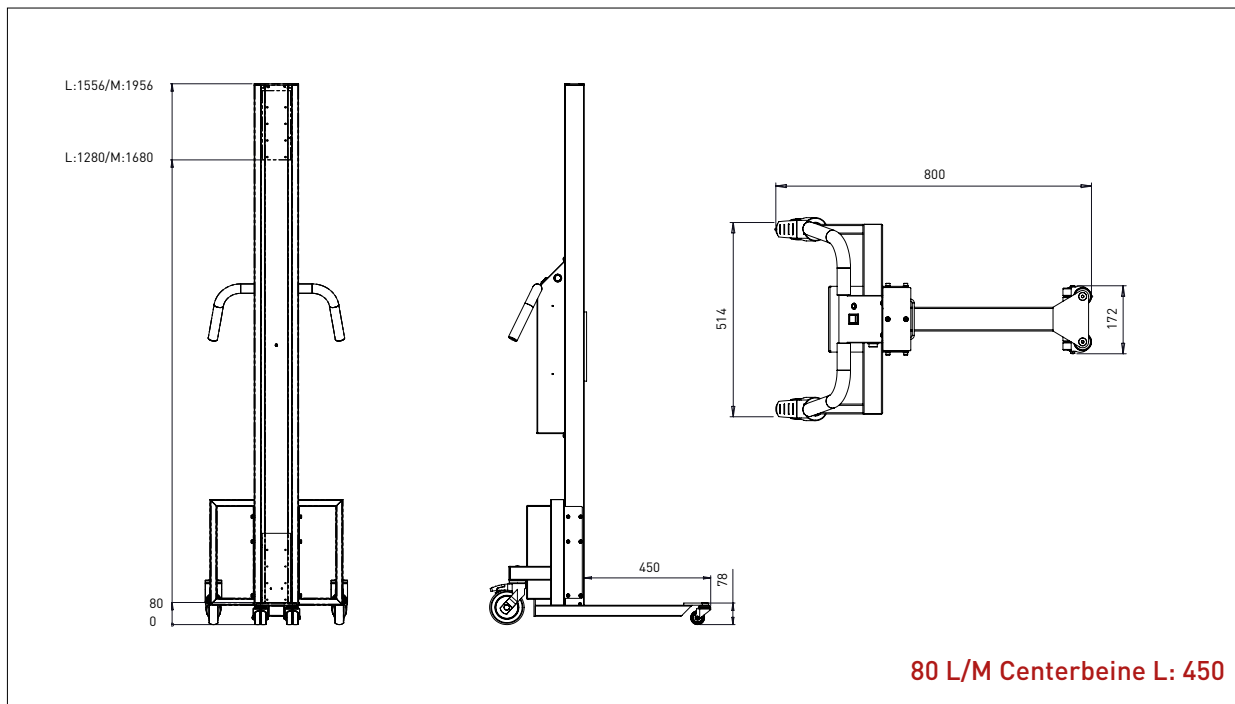
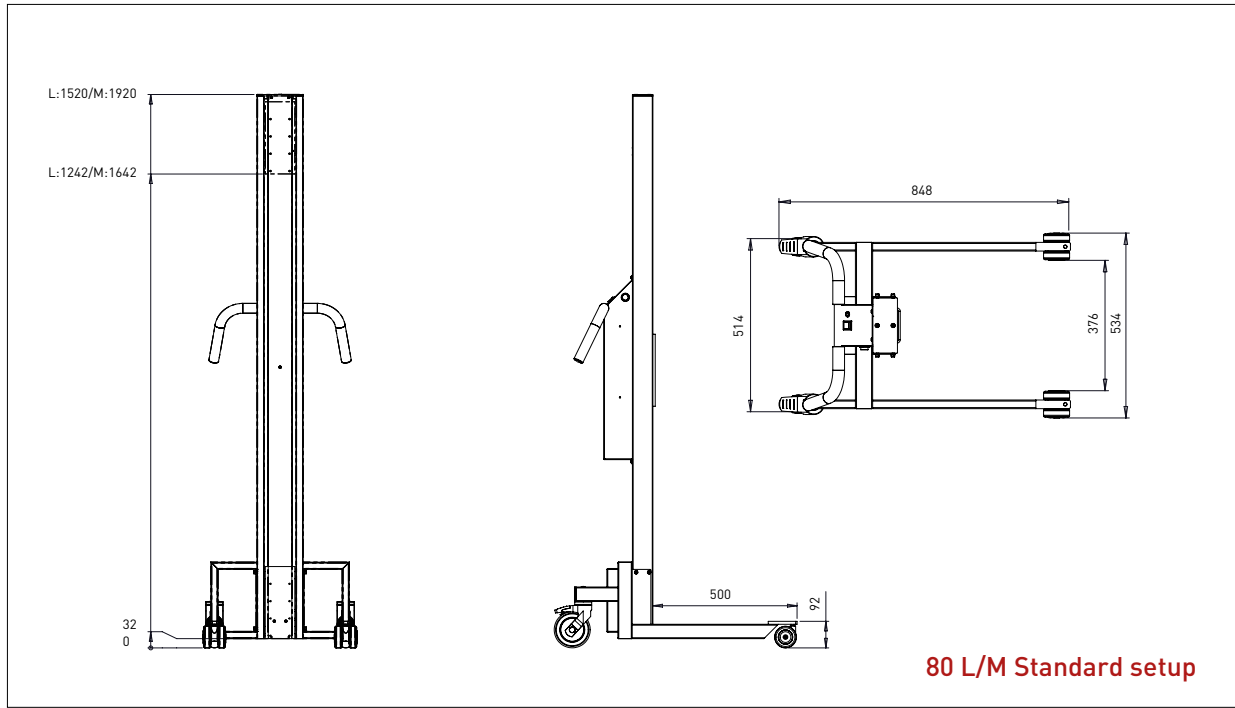

IMPACT 80

HEBELIFTE - ZEICHNUNGEN & MASSE

- Alles masse in mm

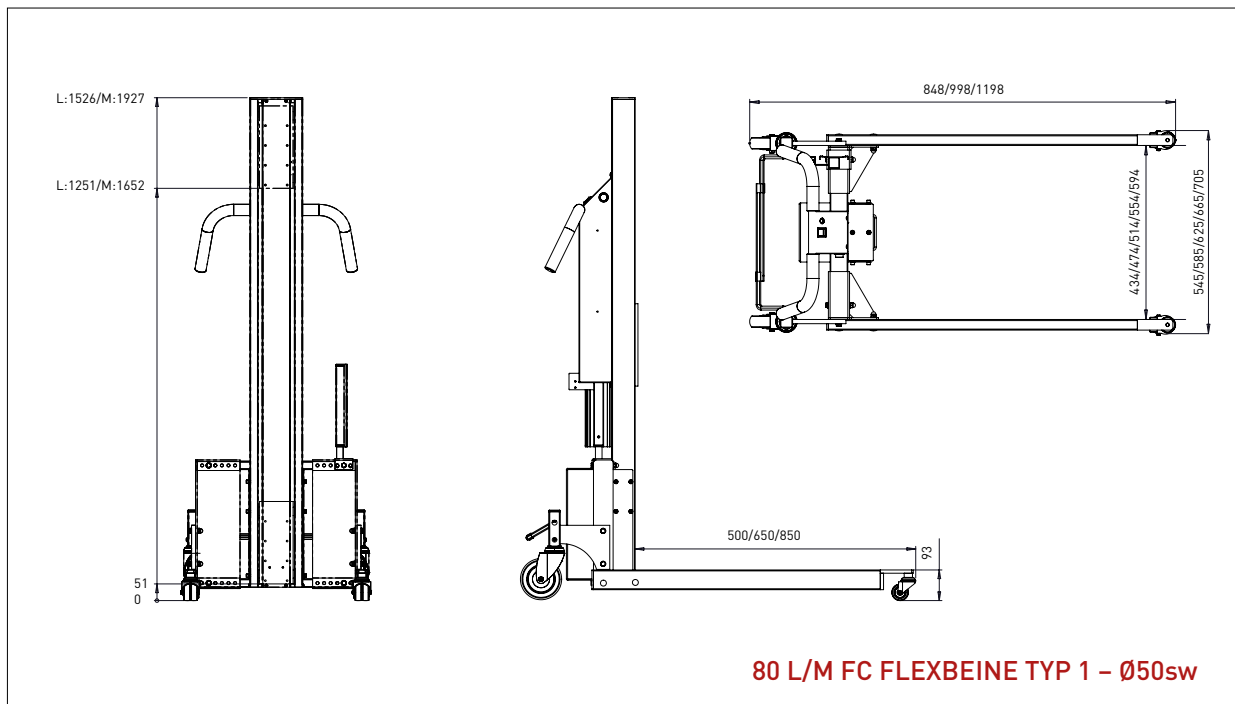
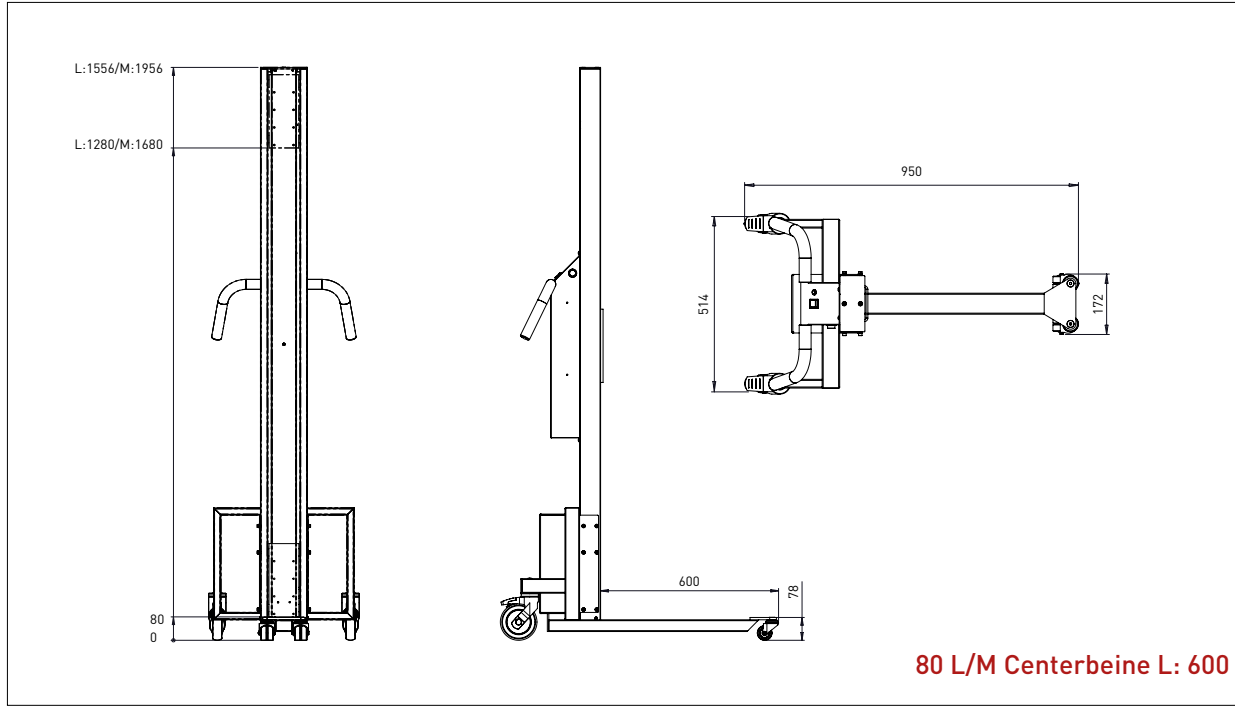

IMPACT 80

HEBELIFTE - ZEICHNUNGEN & MASSE

- Alles masse in mm

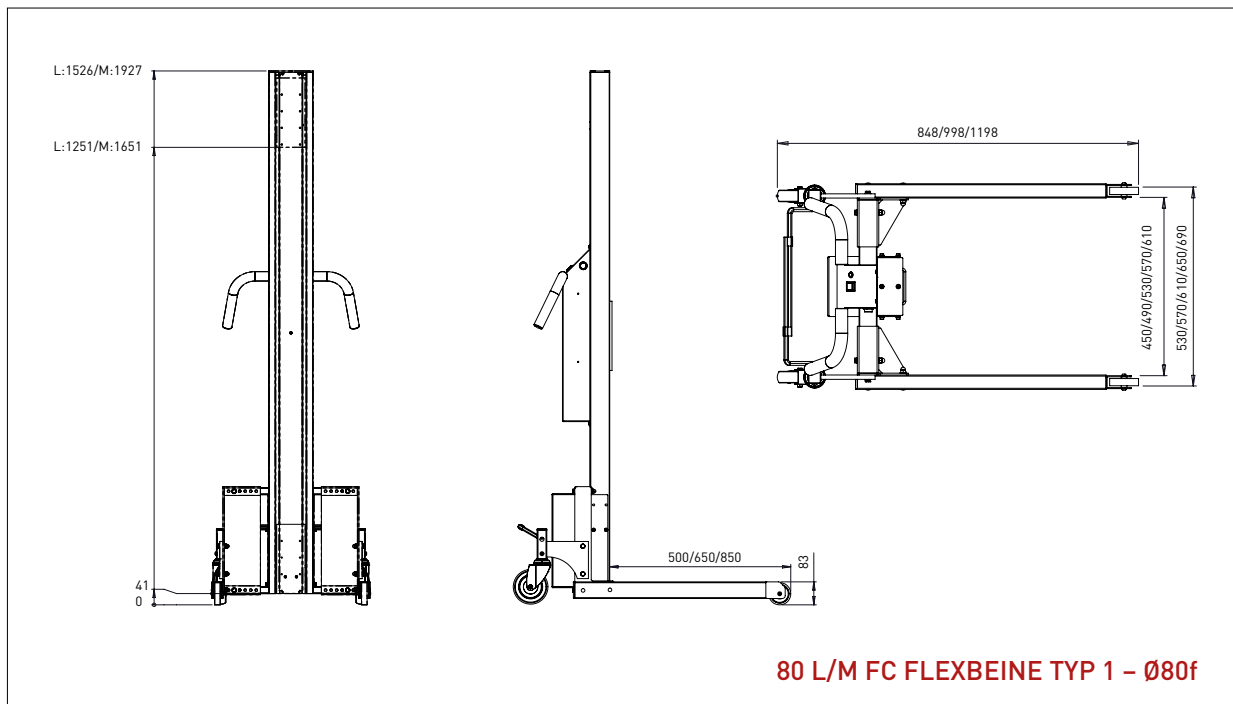
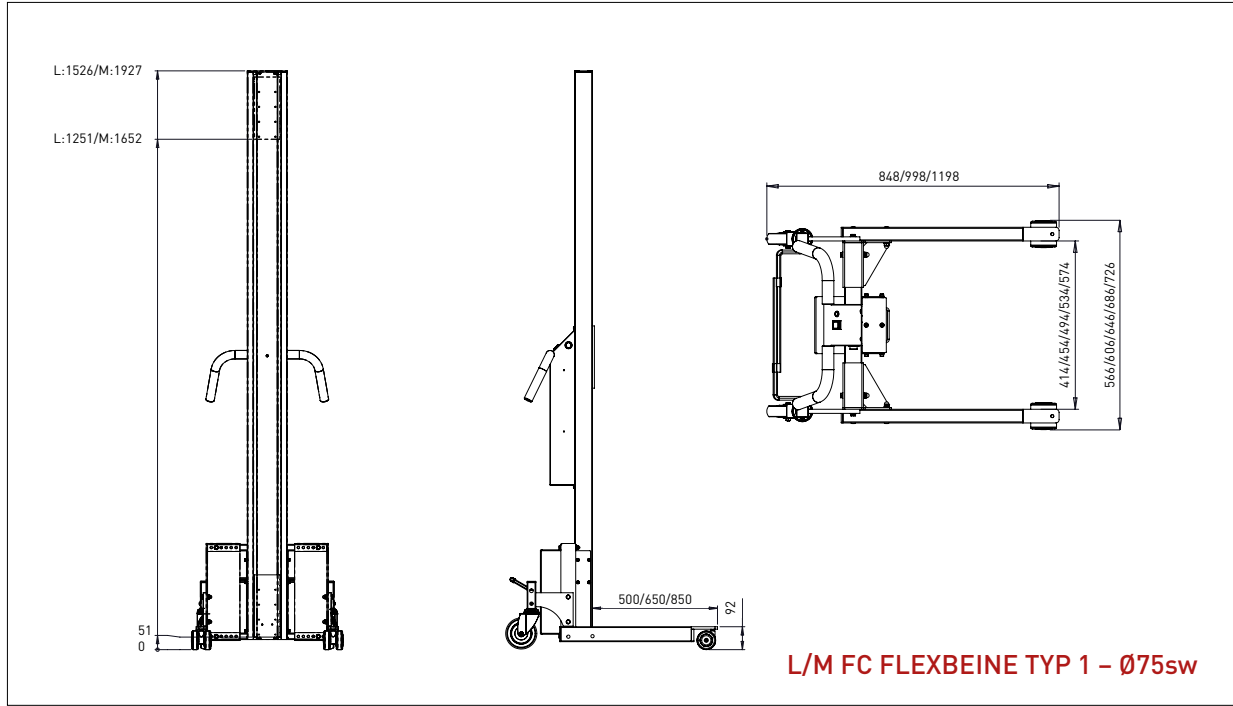

IMPACT 80

HEBELIFTE - ZEICHNUNGEN & MASSE

- Alles masse in mm

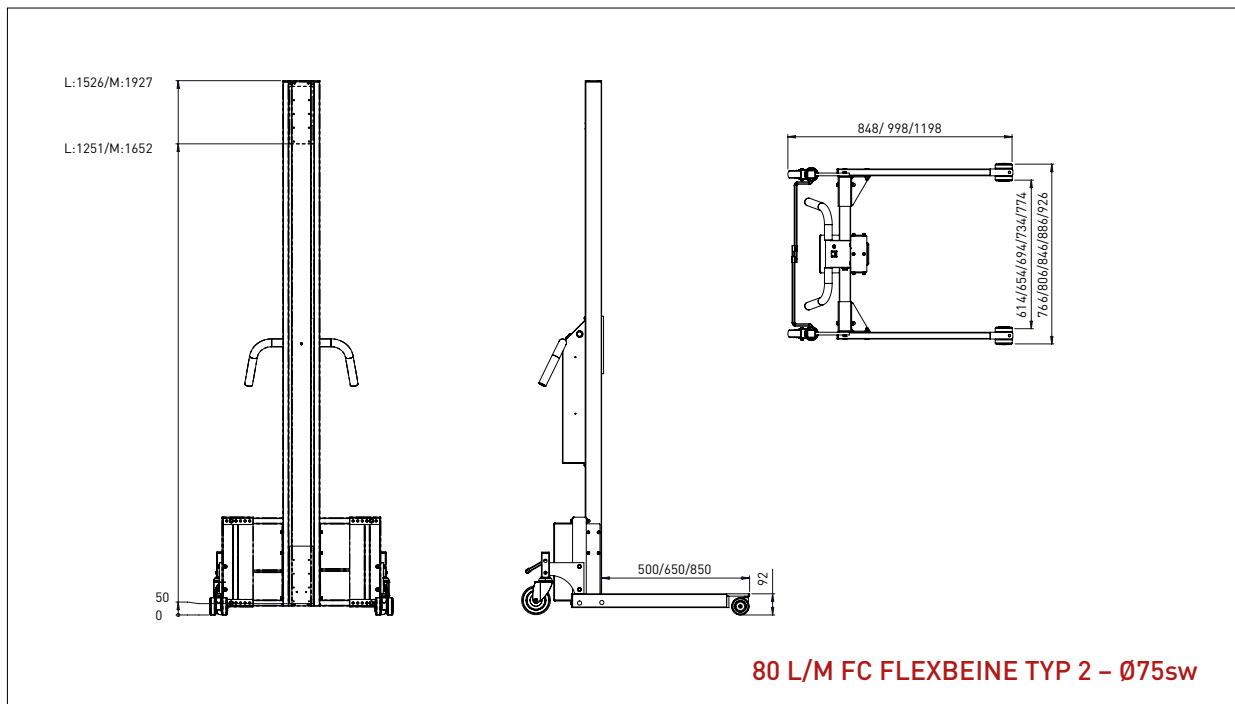
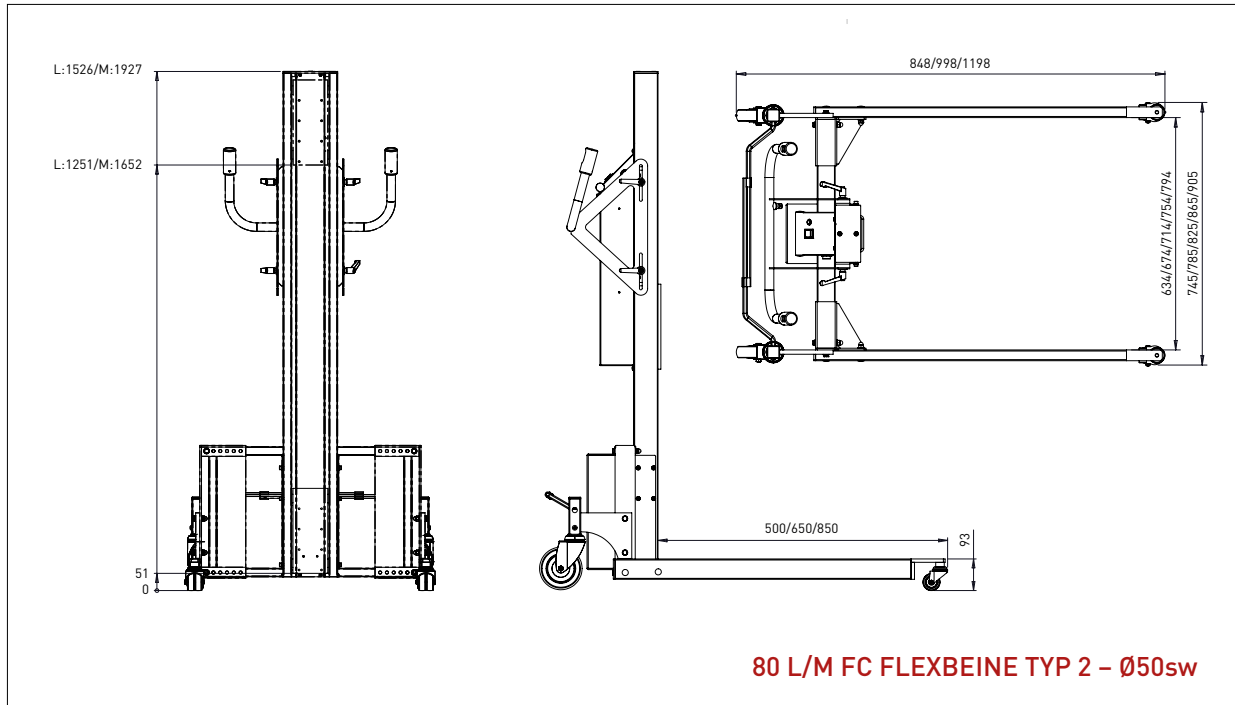

IMPACT 80

HEBELIFTE - ZEICHNUNGEN & MASSE

- Alles masse in mm

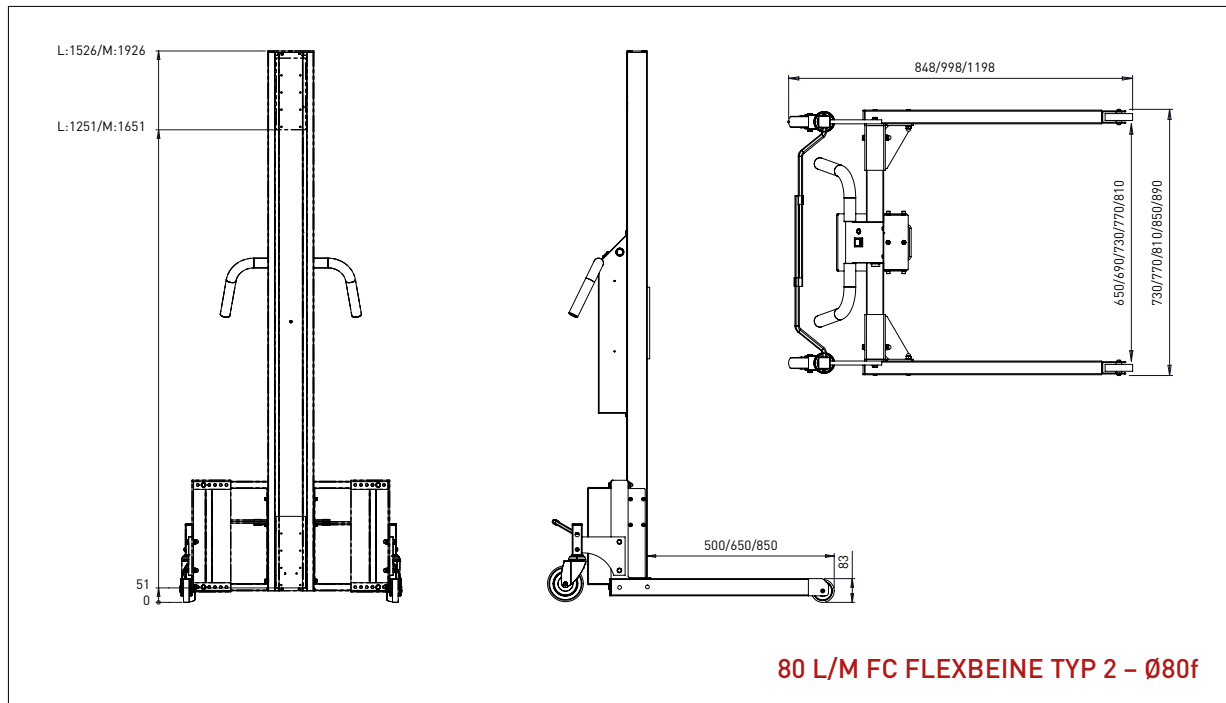

IMPACT 80 / HEBEZEUGE

PLATTFORM, HOLZ

- Alles masse in mm

PLATTFORM, HOLZ - W1

L x B: 400 x 450 mm

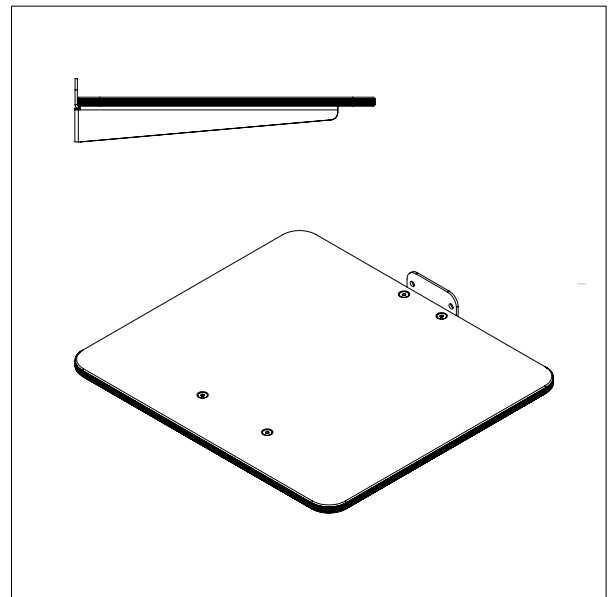
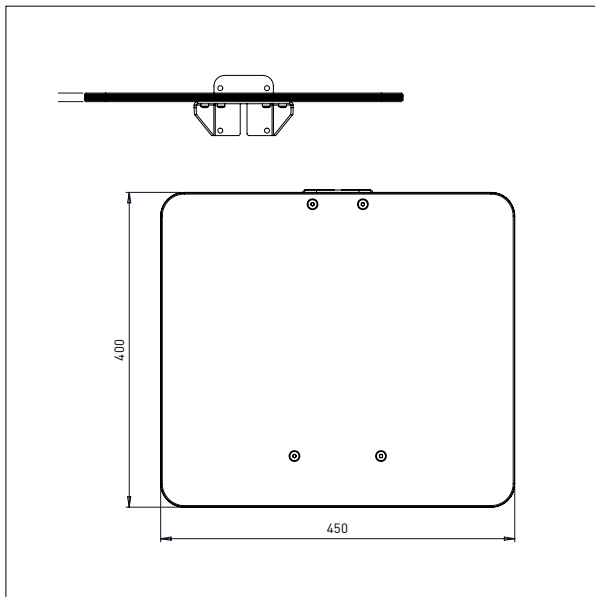

PLATTFORM, HOLZ - W2

L x B: 500 x 500 mm

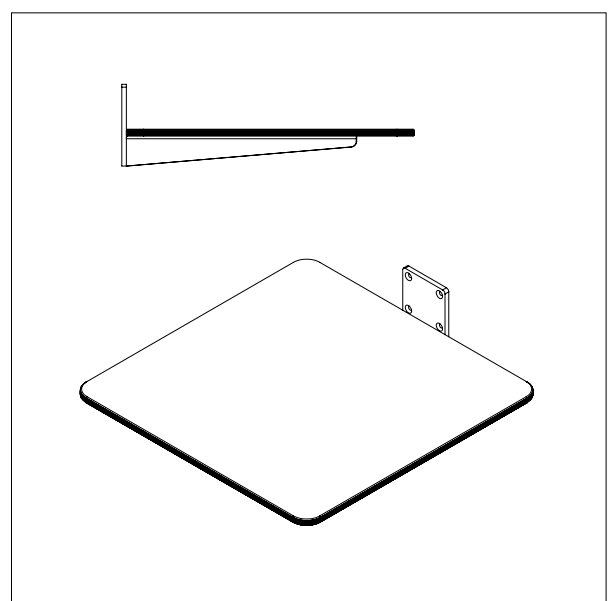
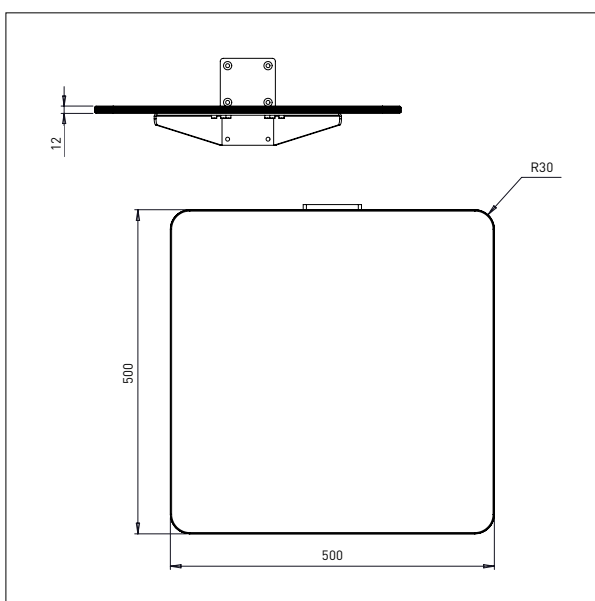

IMPACT 80 / HEBEZEUGE

PLATTFORM, HOLZ

- Alles masse in mm

PLATTFORM, HOLZ - W3

L x B: 600 x 600 mm

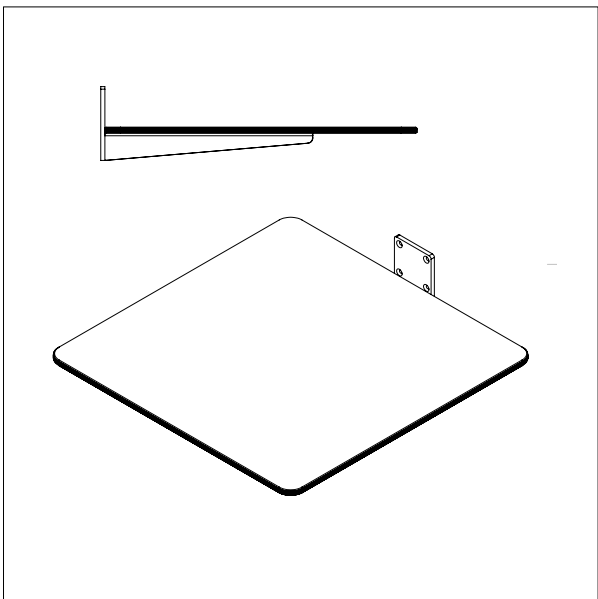
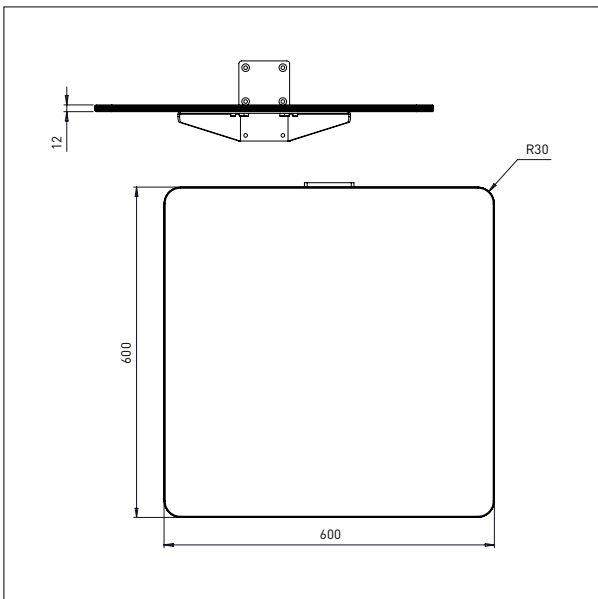

PLATTFORM, HOLZ - W4

L x B: 500 x 500 mm

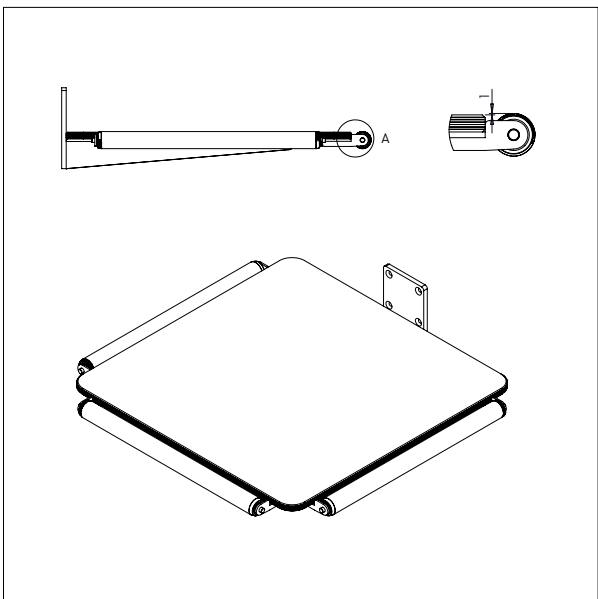
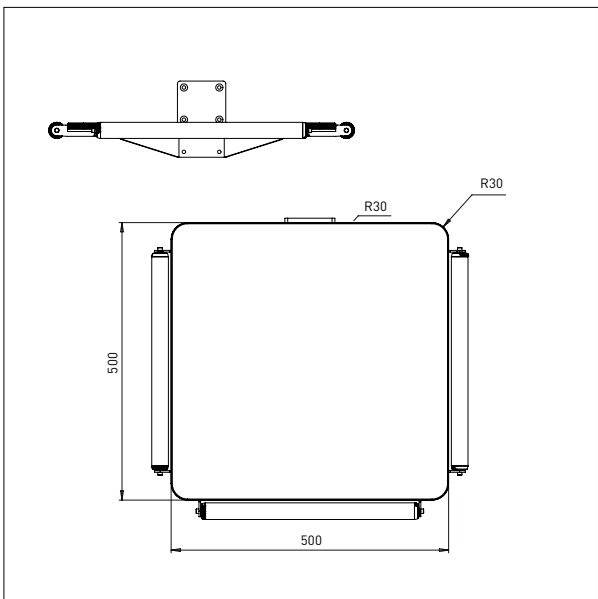

IMPACT 80 / HEBEZEUGE

PLATTFORM, KUNSTSTOFF

- Alles masse in mm

PLATTFORM, KUNSTSTOFF – KP1

L x B: 495 x 495 mm

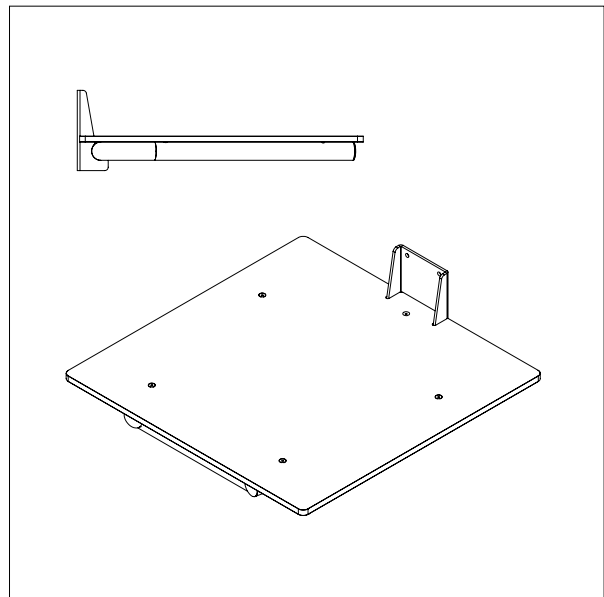
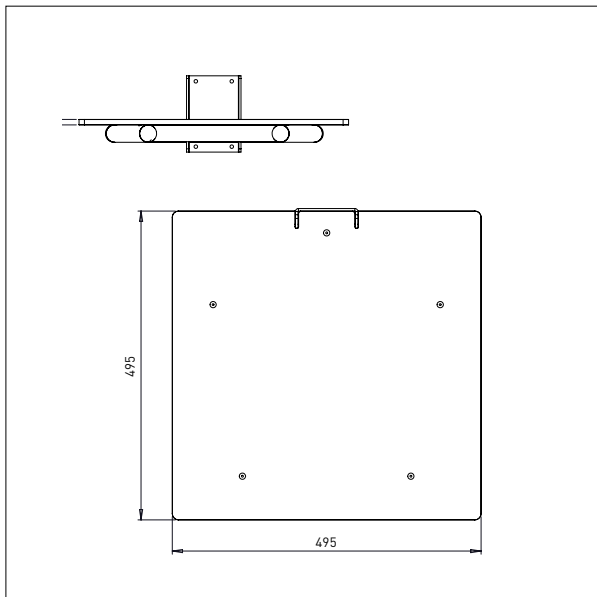

PLATTFORM, KUNSTSTOFF- KP2

L x B: 600 x 600 mm

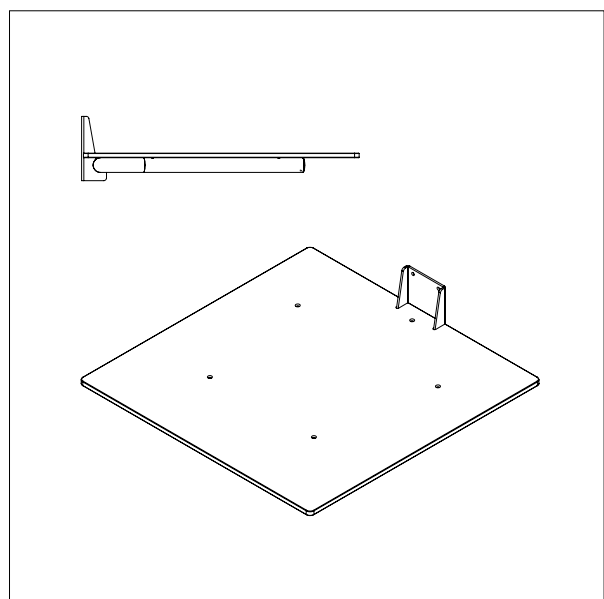
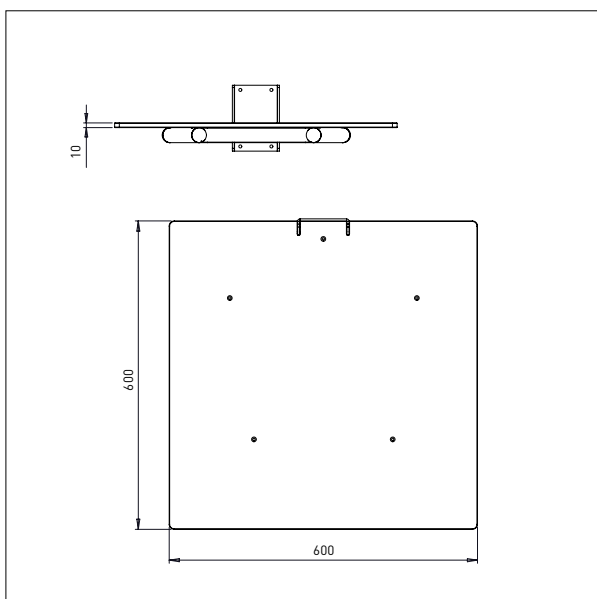

IMPACT 80 / HEBEZEUGE

PLATTFORM, KUNSTSTOFF MIT ROLLEN

- Alles masse in mm

PLATTFORM, KUNSTSTOFF MIT ROLLEN - KP3
L x B: 495 x 495 mm

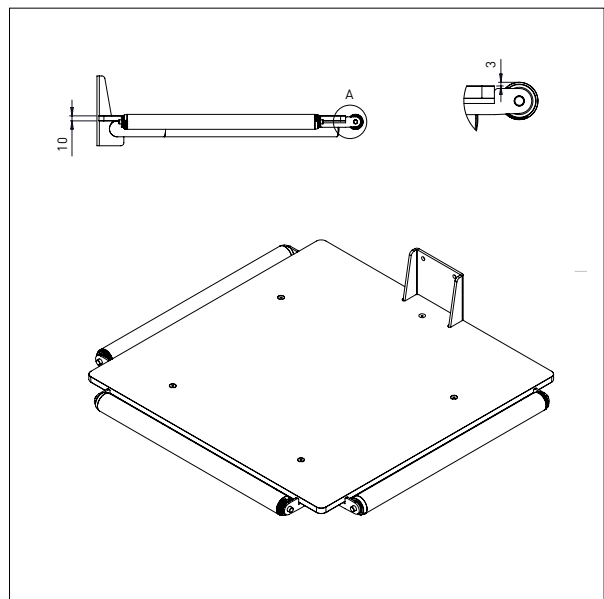
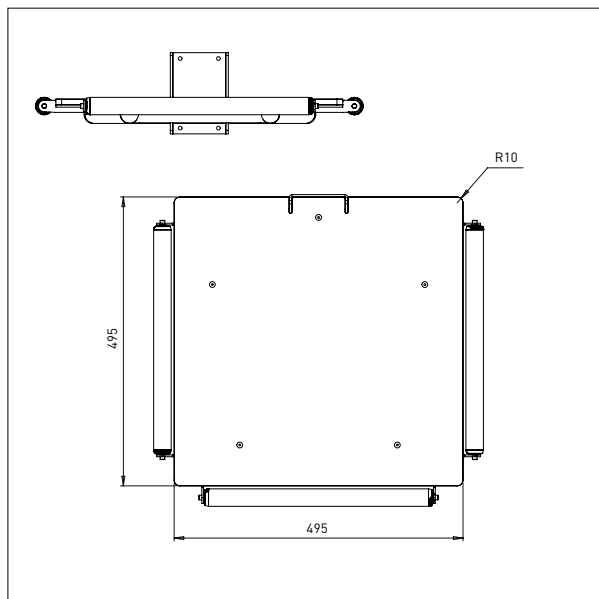

IMPACT 80 / HEBEZEUGE

PLATTFORM, EDELSTAHL

- Alles masse in mm

PLATTFORM, EDELSTAHL – EP1

L x B: 500 x 400 mm

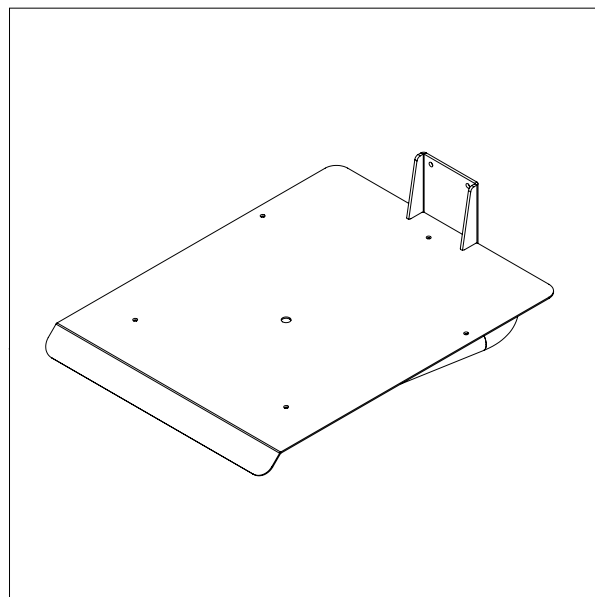
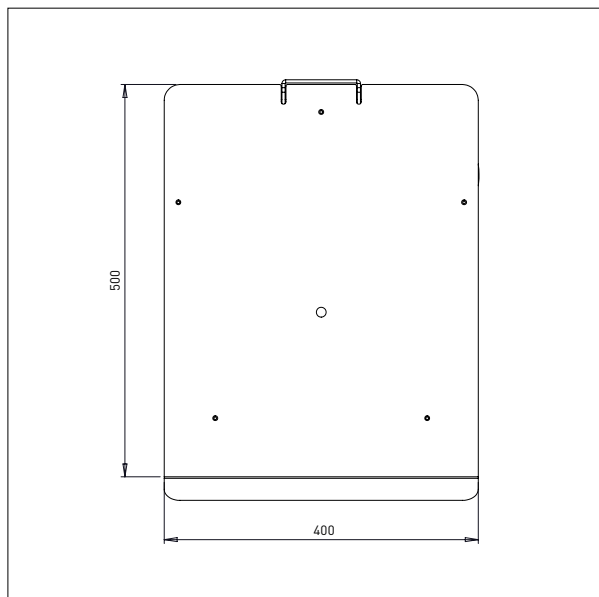

PLATTFORM, EDELSTAHL – EP2

L x B: 500 x 500 mm

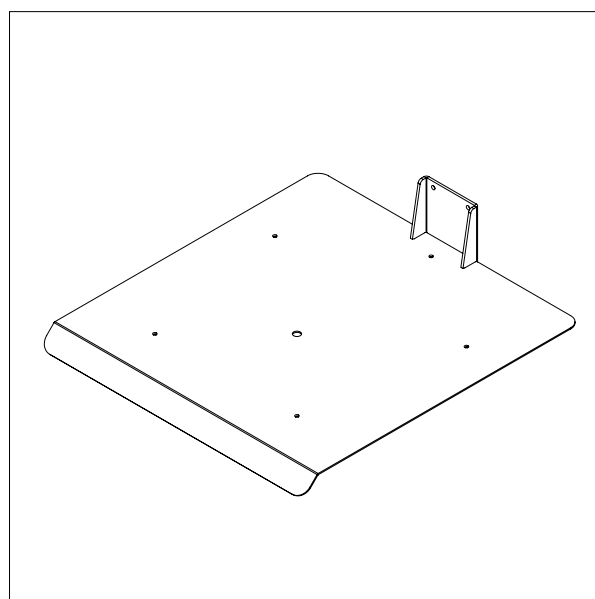
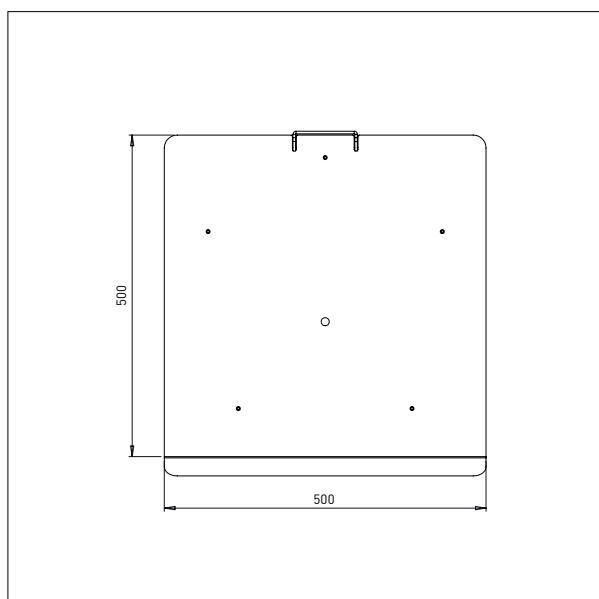

IMPACT 80 / HEBEZEUGE

DORN

- Alles masse in mm

DORN - D1 Ø x L: 60 x 500 mm

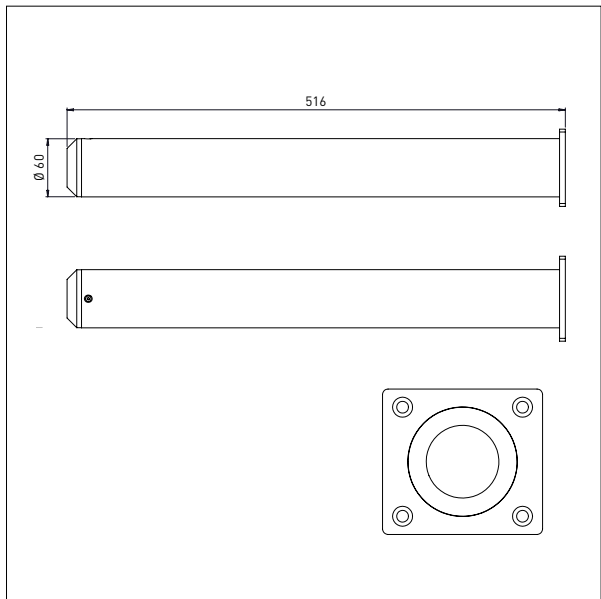
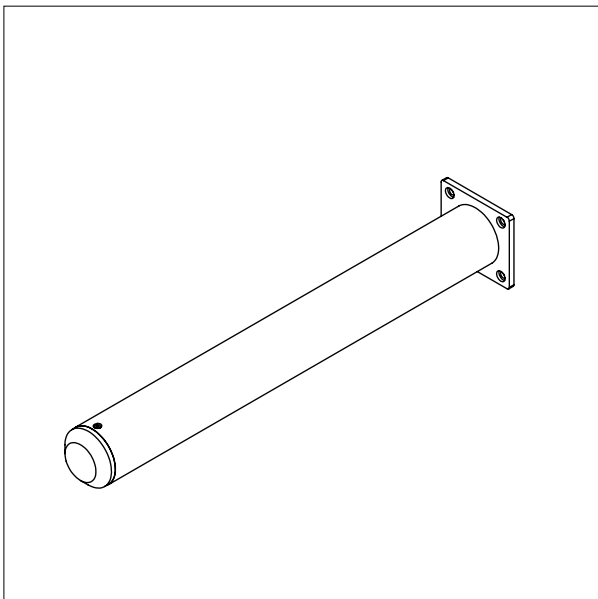

DORN - D2 Ø x L: 60 x 800 mm

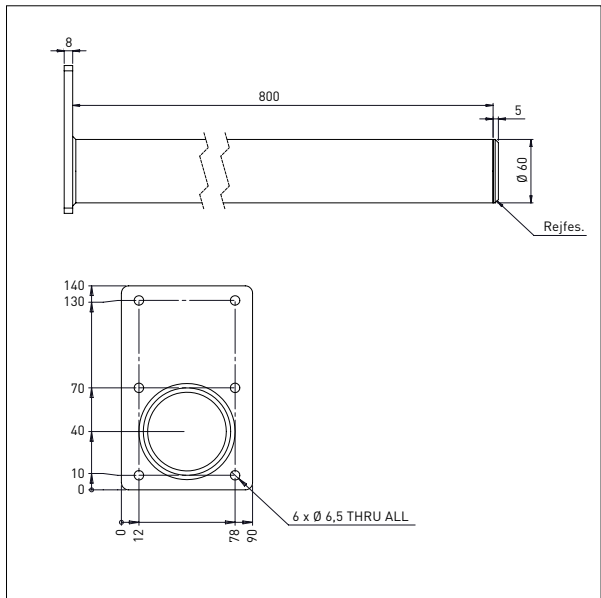
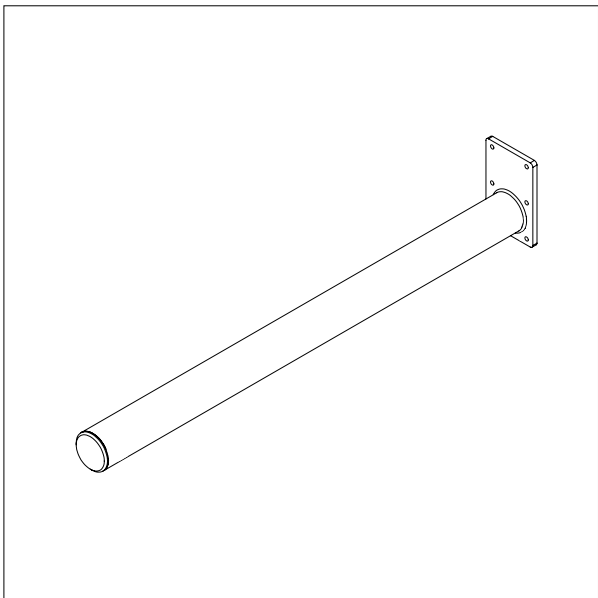

IMPACT 80 / HEBEZEUGE

DOPPELDORN

- Alles masse in mm

DOPPELDORN – DD1 Min. breite von Rollen: \varnothing 300 mm
 \varnothing x L x B: 32 x 500 x 250 mm Max. breite von Rollen: \varnothing 400 mm

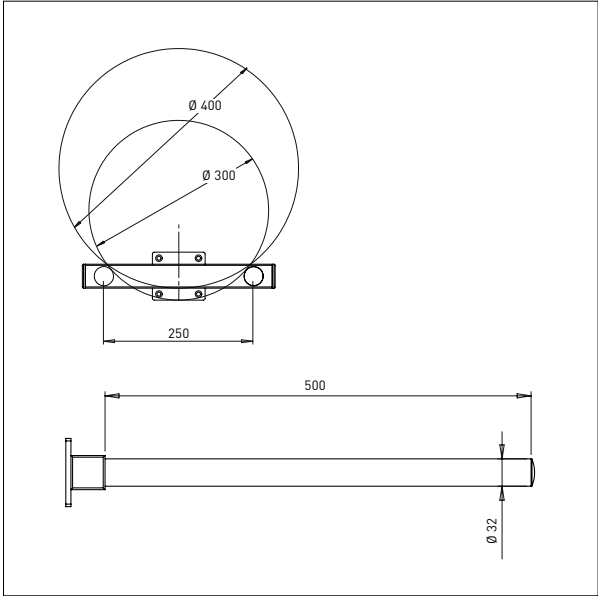
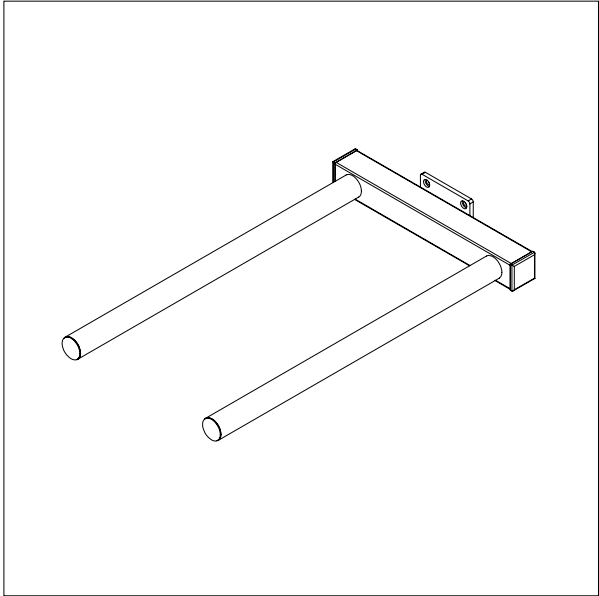

DOPPELDORN – DD2 Min. breite von Rollen: \varnothing 400 mm
 \varnothing x L x B: 32 x 500 x 350 mm Max. breite von Rollen: \varnothing 800 mm

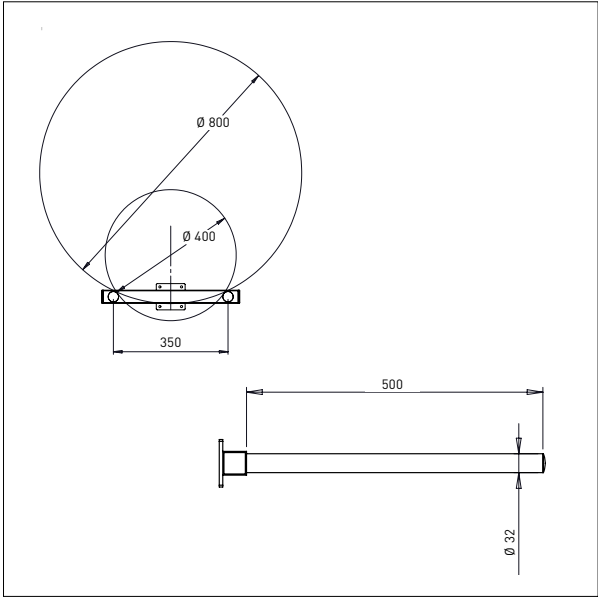
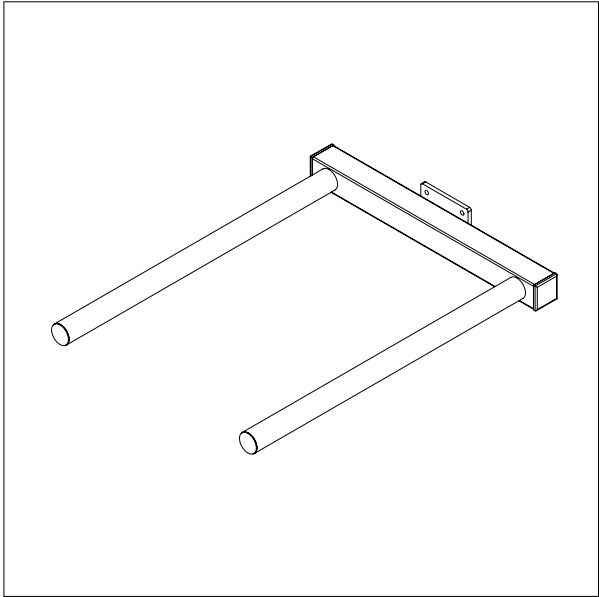

IMPACT 80 / HEBEZEUGE

GABEL

- Alles masse in mm

GABEL - G1

L x B: 585 x 375 mm

Für 600 x 400 mm kästen

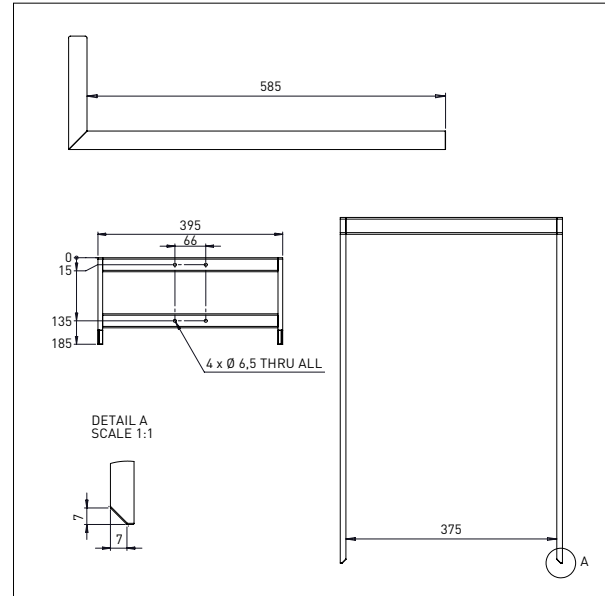
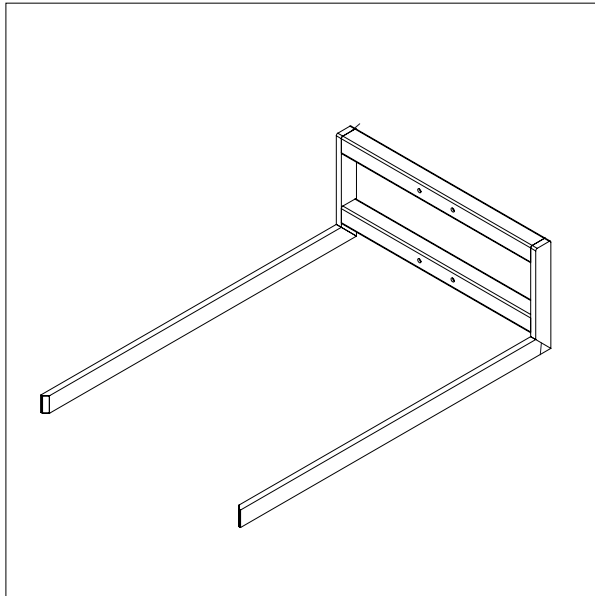

IMPACT 80 / HEBEZEUGE

DORN MIT V-BLOCK

- Alles masse in mm

DORN MIT V-BLOCK - DVB1

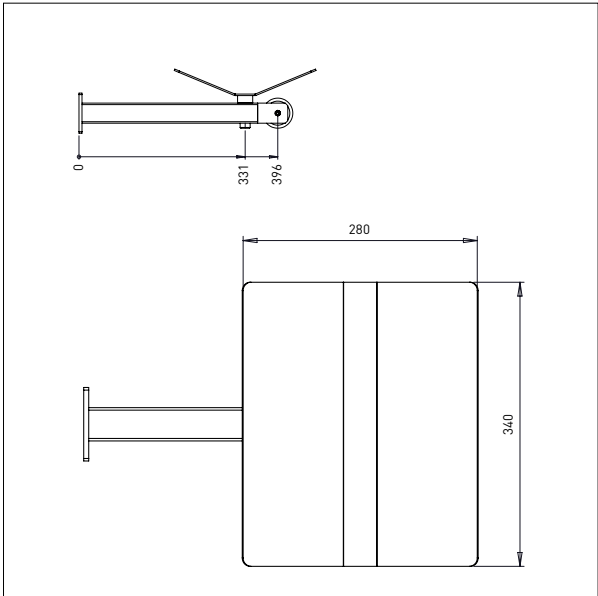
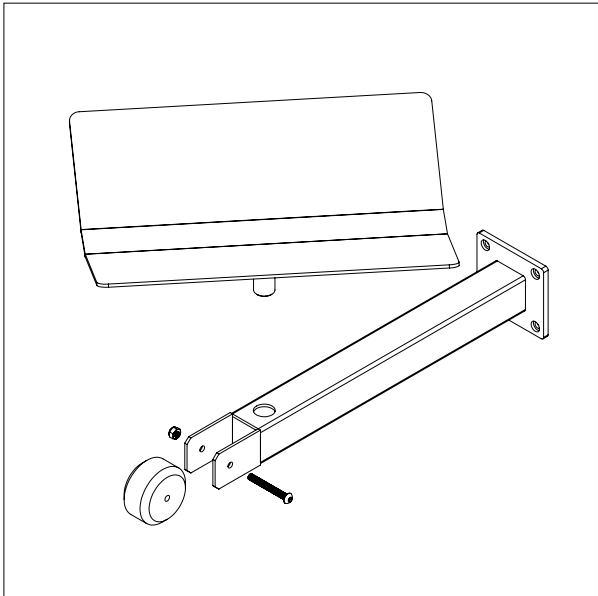

DORN MIT V-BLOCK - DVB2 (EDELSTAHL)

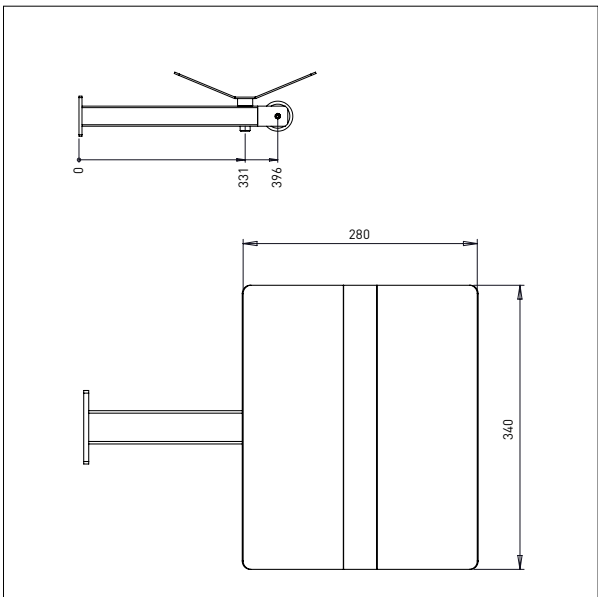
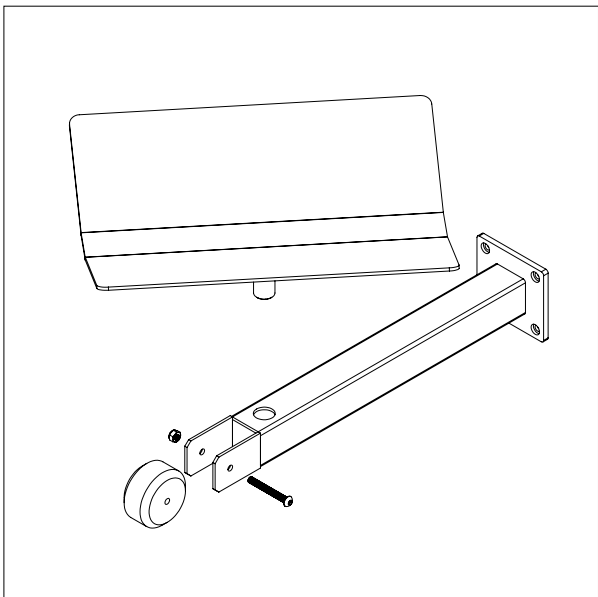

IMPACT 80 / HEBEZEUGE

PLATTFORM MIT V-BLOCK

- Alles masse in mm

PLATTFORM MIT V-BLOCK - EPV

Plattform: 500 x 400

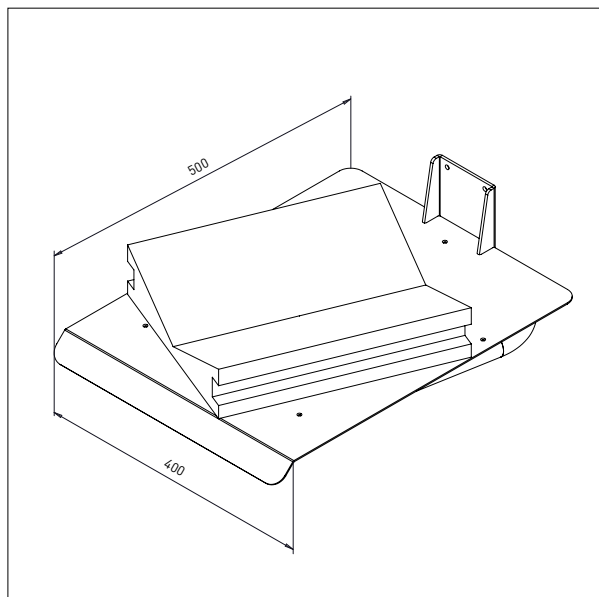

IMPACT 80 / HEBEZEUGE

KRAN ARMEN

- Alles masse in mm

KRAN ARM - KA1 L: 600

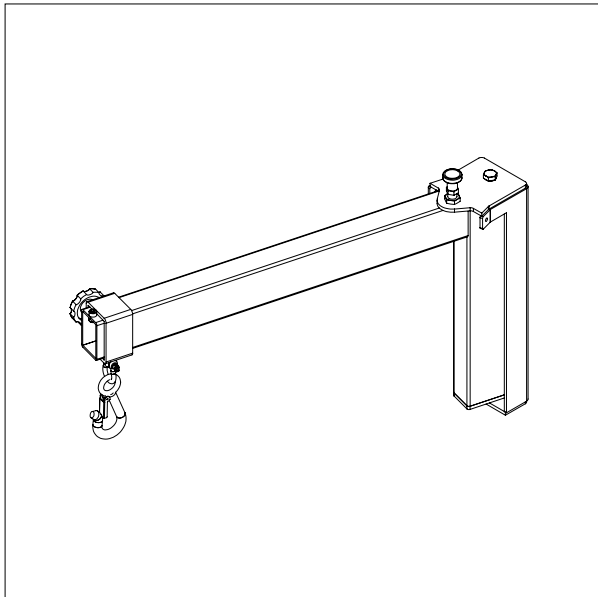
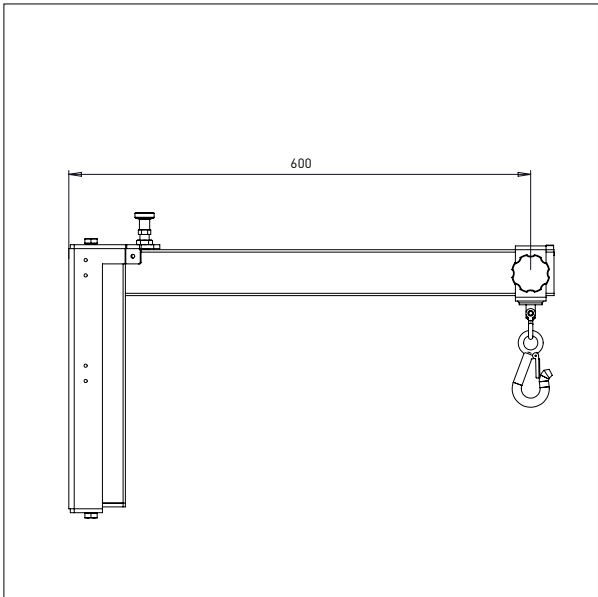

KRAN ARM - KA2 L: 800

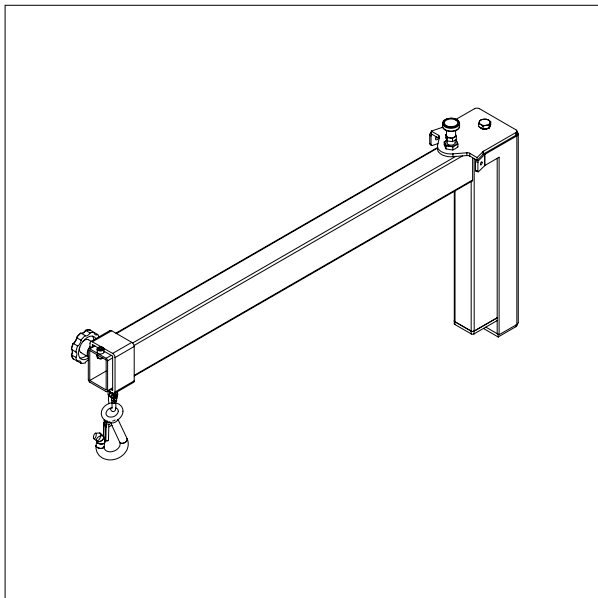
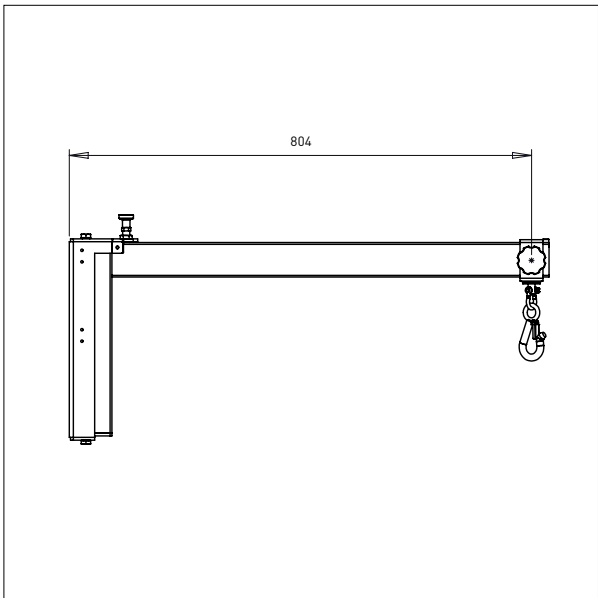

IMPACT 80 / HEBEZEUGE

Selbstschliessend dorn

- Alles masse in mm

Selbstschliessend dorn

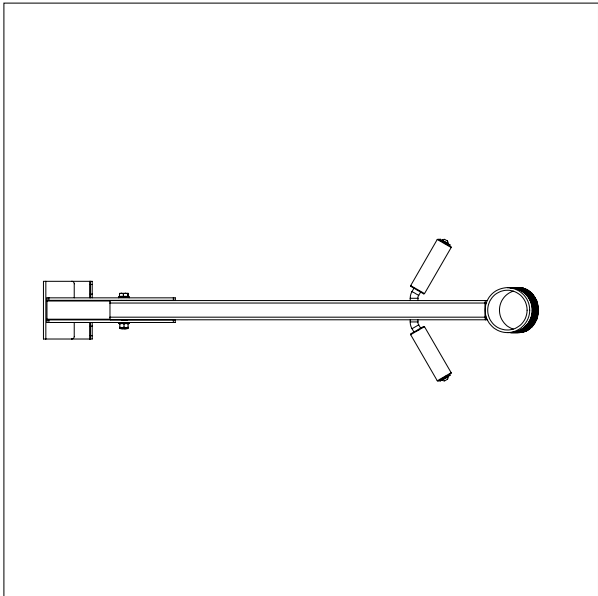
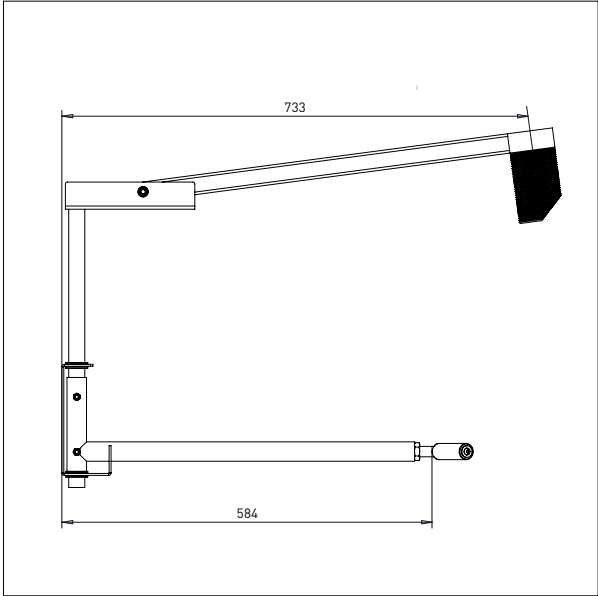
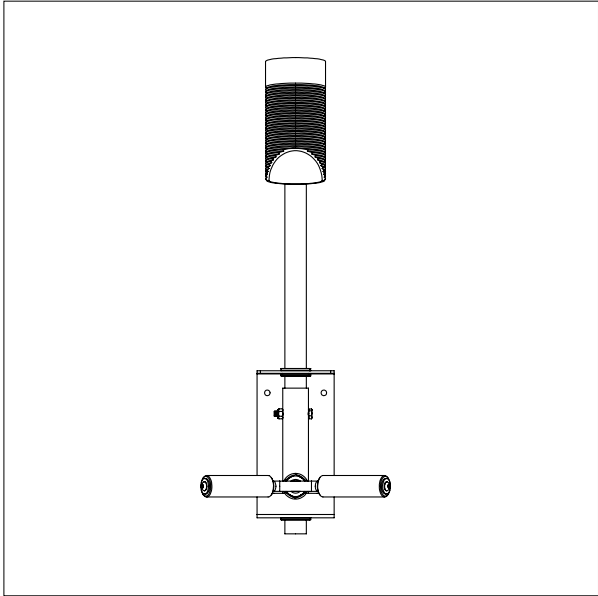

IMPACT 80 / HEBEZEUGE

ROLLENMANIPULATOR

- Alles masse in mm

ROLLENMANIPULATOR - MRP1

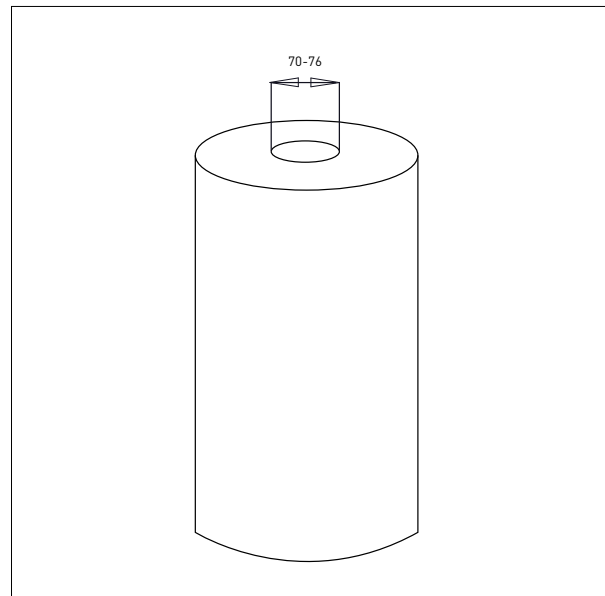
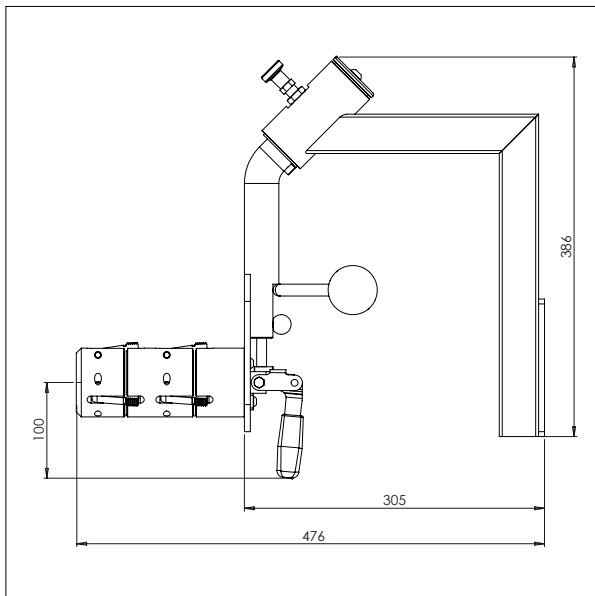
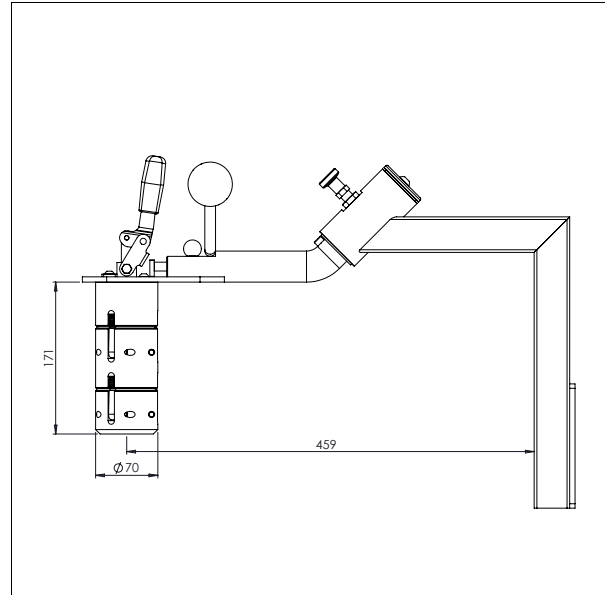
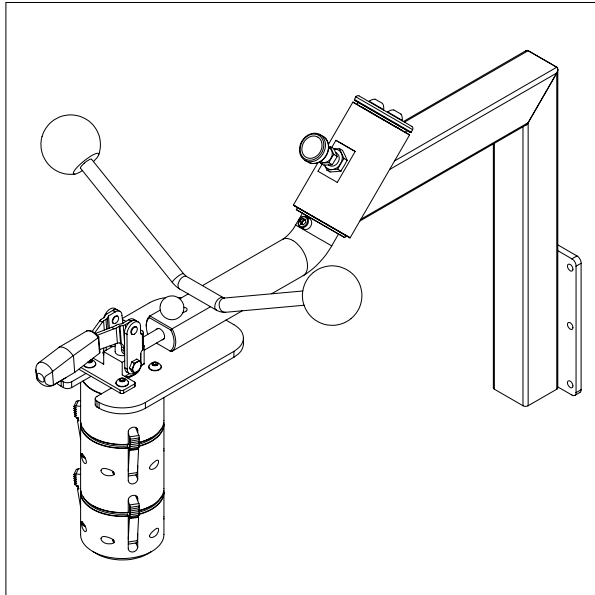

IMPACT 80 / HEBEZEUGE

ROLLENMANIPULATOR

- Alles masse in mm

ROLLENMANIPULATOR - MRP2

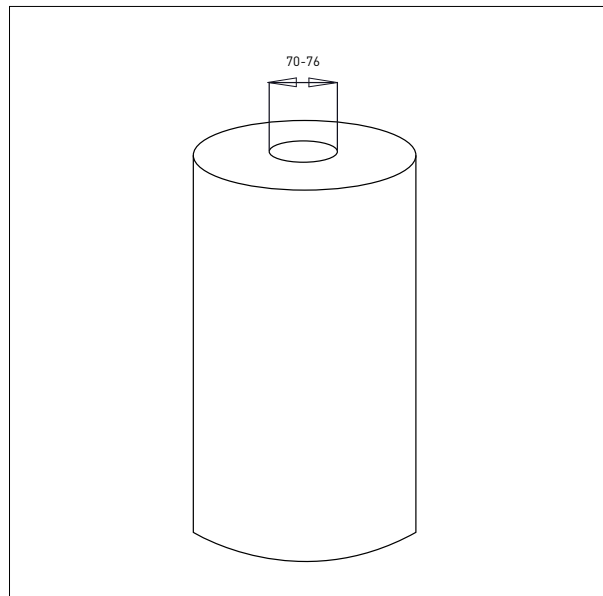
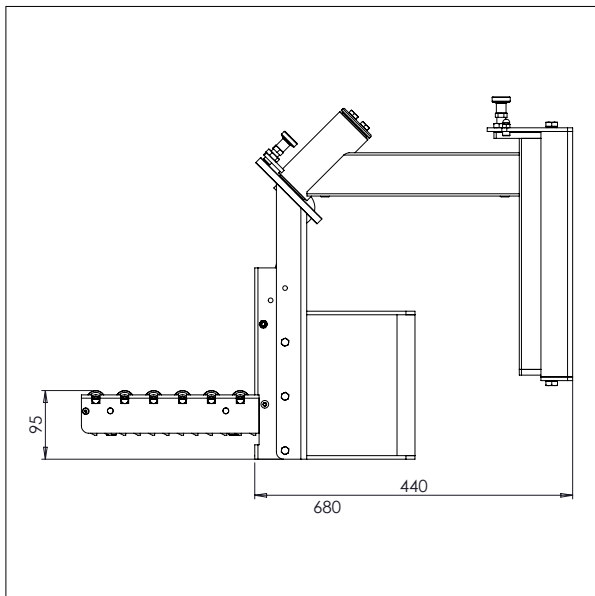
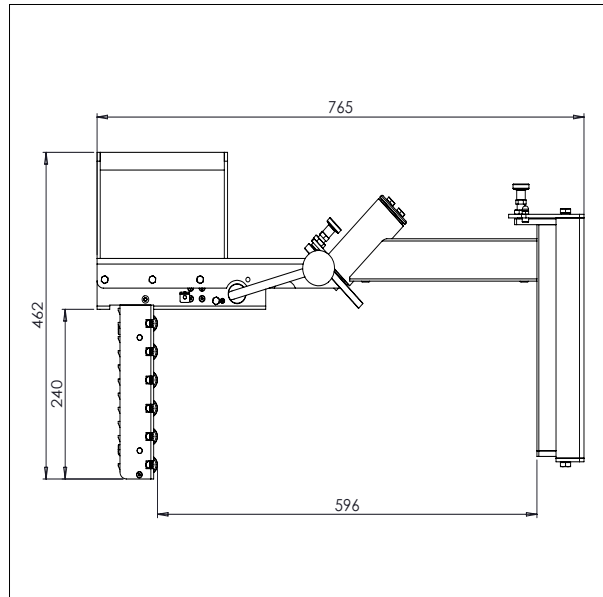
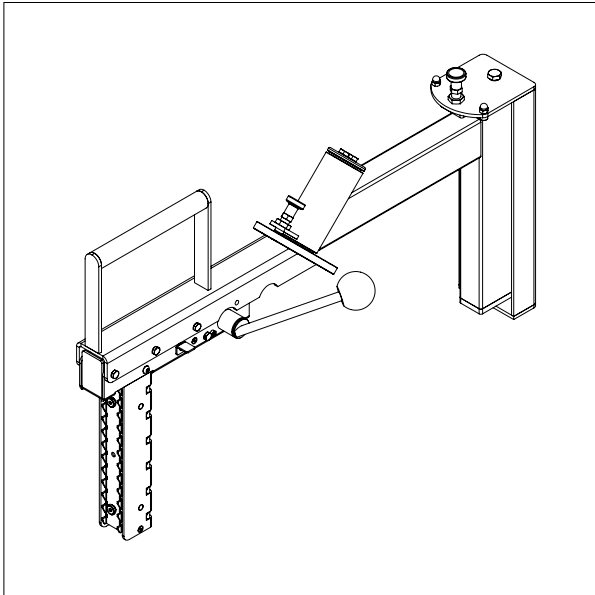

IMPACT 80 / HEBEZEUGE

DORNVERGRÖßERN

- Alles masse in mm

DORNVERGRÖßERN - CL1 Für: Ø125 mm/6"

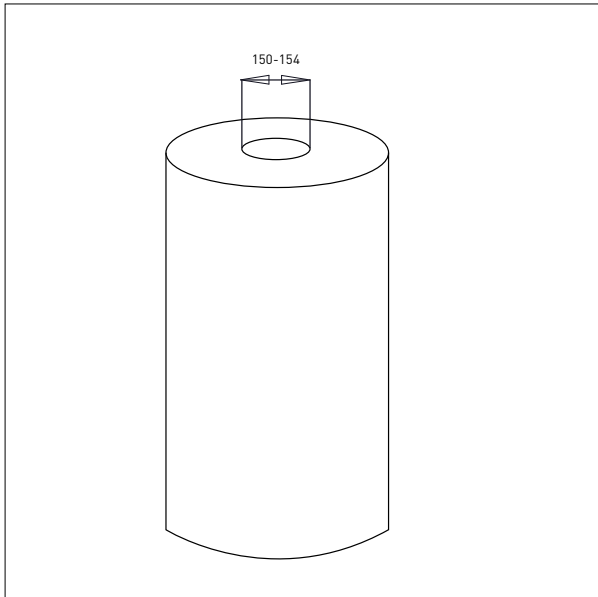
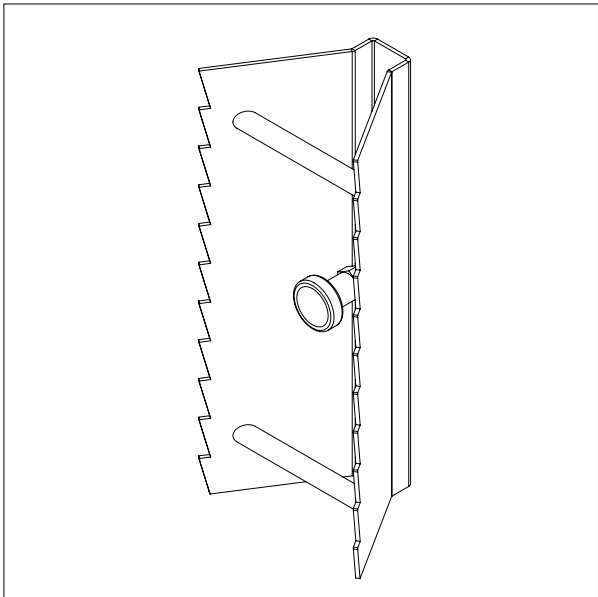

DORNVERGRÖßERN- CL2 Für: Ø254mm/10"

