

UNITED STATES PATENT AND TRADEMARK OFFICE

BEFORE THE PATENT TRIAL AND APPEAL BOARD

ORTHOPEDIATRICS CORP.,
Petitioner,

v.

K2M, INC.,
Patent Owner.

Case IPR2018-01546
Patent 9,655,664 B2

Before LYNNE H. BROWNE, MICHAEL L. WOODS, and
ROBERT L. KINDER, *Administrative Patent Judges*.

BROWNE, *Administrative Patent Judge*.

DECISION
Denying Institution of *Inter Partes* Review
35 U.S.C. § 314

I. INTRODUCTION

OrthoPediatrics Corp. (“Petitioner”), on August 21, 2018, filed a Petition to institute *inter partes* review of claims 1, 3, 5, 6, 8–10, 12, and 15–19 of U.S. Patent No. 9,655,664 B2 (“the ’664 patent”). Paper 1 (“Pet.”). K2M, Inc. (“Patent Owner”) filed a Preliminary Response to the Petition on November 29, 2018. Paper 6 (“Prelim. Resp.”).

Under 35 U.S.C. § 314(a), an *inter partes* review may not be instituted unless the Petition “shows that there is a reasonable likelihood that the petitioner would prevail with respect to at least 1 of the claims challenged in the petition.” For the reasons stated below, we determine that Petitioner has not established a reasonable likelihood that it would prevail in showing the unpatentability of at least one claim of the ’664 patent. Accordingly, we do not institute an *inter partes*.

A. *Related Proceedings*

Petitioner indicates that the ’664 patent is the subject of *K2M, Inc. v. OrthoPediatrics Corp. & OrthoPediatrics US Distribution Corp.*, Case No. 1:17-cv-00061-GMS (D. Del.). Pet. 1. Petitioner further indicates that the ’664 patent is related to U.S. Patent No. 9,532,816 (“the ’816 patent”), which is also the subject of the district court litigation.

Petitioner concurrently filed two other petitions requesting *inter partes* review challenging claims 1, 3, 5, 6, 8–10, 12, and 15–19 of the ’664 patent. IPR2018-01547; IPR2018-01548.

We further note that the ’816 patent is the patent at issue in *inter partes* review proceedings IPR2018-00429 and IPR2018-00521. As the ’664 patent is a divisional of the ’816 patent, these patents share the same

Specification. Accordingly, IPR2018-00429 and IPR2018-00521 are also related proceedings.

B. The '664 Patent

The '664 patent is directed to “devices for stabilizing and fixing the bones and joints of the body.” Ex. 1001, 2:18–19. Particularly, the present invention relates to “a manually operated device capable of reducing a rod into position in a rod receiving notch in the head of a bone screw with a controlled, measured action.” Ex. 1001, 1:20–22. The device described in the '664 patent achieves this objective by grasping “the head of a bone screw and reduc[ing] a rod into the rod receiving recess of the bone screw using a single manual control that can be activated in a controlled and measured manner.” *Id.* at 2:25–28.

Figure 4 reproduced below illustrates the device:

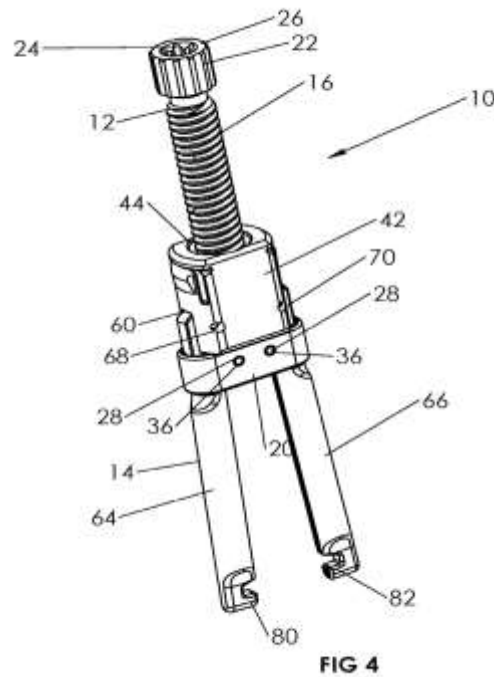

Figure 4 is an isometric view of the rod reducing device with the screw jack mechanism fully retracted and the two elongated grasping members in an open configuration. Ex. 1001, 3:2–32.

The '664 patent explains:

The device . . . is a rod reduction device capable of reducing a rod into position in a rod receiving notch in the head of a bone screw with a controlled, measured action. The device is an elongated rod reduction device 10 that includes a screw jack mechanism 12 moveably engaged with an elongated grasping fork assembly 14. The screw jack mechanism 12 includes an elongated threaded screw shaft 16 that terminates at its most proximal end with a controlling member 18 and terminates at its most distal end with a rod contact member 20.

Id. at 3:65–4:7 (emphasis omitted).

C. Illustrative Claim

Petitioner challenges claims 1, 3, 5, 6, 8–10, 12, and 15–19 of the '664 patent. Claims 1, 8, 12, and 17 are independent. Representative claim 1 is reproduced below:

1. A method of advancing a rod into a housing of a bone anchor comprising:
 - coupling a rod reducing device to a bone anchor, the bone anchor having a rod-receiving housing and a bone engaging shaft extending therefrom, the rod reducing device including:
 - a rotatable member,
 - a rod contact member positioned at a distal end of the rotatable member, and
 - a body including first and second elongated grasping members extending therefrom, each of the first and second elongated grasping members having a screw grasping element, the rotatable member threadably coupled with the body, the first and second elongated grasping members defining a plane, the rotatable member and the rod contact member movable within the plane;

securing the rod reducing device to the bone anchor by engaging the first and second elongated grasping members with the rod-receiving housing so that the rod receiving housing is disposed between the first and second elongated grasping members; and

rotating the rotatable member thereby causing the rod contact member to move relative to the body within the plane to advance a rod disposed between the first and second elongated grasping members toward the rod-receiving housing.

Ex. 1001, 8:9–35.

D. References Relied Upon

The Petitioner relies on the following references:

Name	Reference	Ex. No.
Iott	US 2006/0247630 A1, published Nov. 2, 2006	1017
Justis	US 2007/0213714 A1, published Sept. 13, 2007	1018
Sparker	US Des. 346,217, issued Apr. 19, 1994	1019
DePuy 1998	Lumbar Degenerative Pathologies: DePuy AcroMed's Comprehensive Low Back Set for Intraoperative Flexibility, published 1998	1020
DePuy 1999	Isola® Spinal System: Ordering Information for Implants and Instruments, published 1999	1021
DePuy 2002	Isola®/VSP® Spine Systems: Product Catalog, published 2002	1022

Pet. 3.

E. The Asserted Grounds of Unpatentability

Petitioner asserts the challenged claims are unpatentable on the following grounds:

Reference(s)	Basis	Claims challenged
Iott	§ 102(a),(e)	1, 3, 5, 6, 8–10, 12, and 15–19
Iott and Justis	§ 103(a)	9, 15, and 17–19
Sparker and DePuy Catalogs ¹	§ 102(b)	8, 10, 12, and 16
Sparker, DePuy Catalogs, and Justis	§ 103(a)	9, 15, and 17–19

Pet. 4. Petitioner supports its challenge with the Declaration of Ottie Pendleton, dated August 21, 2018 (“Pendleton Declaration”) (Ex. 1016).

II. ANALYSIS

Petitioner contends that no “specific claim terms of the Challenged Claims require construction for the purposes of this petition.” Pet. 4. On the other hand, Patent Owner asserts that the ““grasping members” limitation and “extending through the housing” should be construed. Prelim. Resp. 10–11.

In related proceedings IPR2018-00429 and IPR2018-00521, we construed the claim limitation “extending through the housing” found in the claims of the ’816 patent at issue in those proceedings, but did not construe the “grasping members” limitation also found in the claims of that patent. *OrthoPediatrics Corp. v. K2M, Inc.*, IPR2018-00429, Paper 8, 6; IPR2018-

¹ Like Petitioner, we refer collectively to DePuy 1998, DePuy 1999, and DePuy 2002 as “DePuy Catalogs.” See Pet. 65 (“the DePuy 1998 Catalog, the DePuy 1999 Catalog, and the DePuy 2002 Catalog, or collectively, the ‘DePuy Catalogs’”).

00521, Paper 8, 8 (PTAB June 28, 2018). In those proceedings, we did not construe the “grasping members” limitation because it was not in controversy. *Id.* In this proceeding, similar limitations directed to grasping members are at issue and their construction is necessary to resolve the controversy.

A. Petitioner’s claim construction of the limitations reciting grasping members

In the related District Court proceedings, Petitioner urged the District Court to construe “[b]oth ‘grasping members configured to grasp . . .’ and ‘first and second elongated grasping members’ . . . to invoke means-plus-function claiming under pre-AIA 35 U.S.C. § 112, ¶ 6.” Ex. 2005, 5. The District Court agreed and interpreted these limitations as means-plus-function limitations.² Ex. 1011, 1. Specifically, the District Court determined the claimed function to be “grasping a portion of the bone anchor” and the structure corresponding to this function to be “grasping members 64, 66; grasping elements 80, 82; and ‘rod contact member 20.’” *Id.* These limitations appear in claims 16 and claims 8, 12, and 17, respectively, of the ’816 patent. They are similar to the “grasping members” limitations at issue in this proceeding.

In contrast, after acknowledging that the “grasping members” limitations at issue in this proceeding are “nearly identical to the terms and phrases of the claims challenged in IPR2018-00429 and IPR2018-00521,” Petitioner asserts that “the Board need not and should not construe [these limitations].” Pet. 5 (citing *Vivid Techs., Inc. v. Am. Sci. & Eng’g, Inc.*, 200

² We note that the District Court’s order construing these limitations was issued on May 30, 2018, prior to the filing of the instant petition.

F.3d 795, 803 (Fed. Cir. 1999)). Then Petitioner submits that “[i]n essence, this petition is based on the claim constructions urged by Patent Owner in the related district court litigation.” *Id.*

In support of this submission, Petitioner argues that “[a]lthough Petitioner sought narrower claim constructions in the district court proceedings, the Federal Circuit has observed that the broadest reasonable interpretation of a claim term is often broader than the term’s construction under the *Phillips* standard.” Pet. 6 (citing, *e.g.*, *Facebook, Inc. v. Pragmaus AV, LLC*, 582 F. App’x 864, 869 (Fed. Cir. 2014)). Petitioner further argues that “as the Board recognizes, ‘[o]ur rules do not require positions consistent with related cases in different fora. Our rules require that the parties identify related matters. Various reasons may justify inconsistencies among fora, including differing legal or evidentiary standards, a change in litigation strategy, or a change in position.’” *Id.* (citing *Caterpillar Inc. v. Wirtgen Am., Inc.*, IPR2017-02185, Paper 7, at 11 (PTAB May 3, 2018) (internal citation omitted)).

Petitioner further argues that “[w]ith respect to potential means-plus-function limitations, none of the Challenged Claims contains the word ‘means.’ As such, there is a presumption that none of the Challenged Claims invoke 35 U.S.C. § 112, ¶ 6.” Pet. 6 (citing *Williamson v. Citrix Online, LLC*, 792 F.3d 1339, 1348 (Fed. Cir. 2015)). Petitioner, states that “Patent Owner has not requested any construction under § 112, ¶ 6, and Petitioner has no reason to believe that Patent Owner will do so for purposes of this petition.” *Id.* Petitioner concludes that “[t]he Board, therefore, need not and should not construe any terms or phrases under § 112, ¶ 6.” *Id.*

(citing *Vivid Techs.*, 200 F.3d at 803 (“only those terms need be construed that are in controversy”)).

Upon receipt of Patent Owner’s Preliminary Response, discussed below, which explicitly argues that the claim limitations “first and second elongated grasping members” (claim 1) and “first and second grasping members configured to grasp a portion of the bone anchor therebetween” (claims 8, 12, and 17) should be construed as means-plus-function limitations (*see* Prelim. Resp. 11–12), Petitioner did not request further briefing with respect to claim construction under § 112, ¶ 6.

B. Patent Owner’s claim construction of the limitations directed to grasping members

Patent Owner urges us to adopt the District Court’s claim construction of the limitations directed to grasping members because Petitioner argued for this claim construction in the related District Court litigation. *See* Prelim. Resp. 11–12. Patent Owner summarizes the District Court’s analysis and argues that “[e]ven under the BRI [(broadest reasonable interpretation)] standard, ‘the PTO may not disregard the structure disclosed in the specification corresponding to [means-plus-function] language when rendering a patentability determination.’” *Id.* at 16 (citing *In re Donaldson*, 16 F.3d 1189, 1194–95 (Fed. Cir. 1994) (en banc)).

C. Insufficiency of Petition

In prior related proceedings IPR2018-00429 and IPR2018-00521, construction of similar limitations directed to grasping members was not necessary, because even though Patent Owner proposed claim constructions for those limitations, they were not in controversy. *OrthoPediatrics Corp. v. K2M, Inc.*, IPR2018-00429, Paper 8, 6; IPR2018-00521, Paper 8, 8 (PTAB

June 28, 2018). In this proceeding, however, the construction of the claimed “grasping members” is at issue. *See, e.g.*, Prelim. Resp. 34 (arguing that Iott does not disclose these limitations). Accordingly, in order to resolve the controversy, we must construe these limitations.

Our Rules specifically require that a petition for *inter partes* review set forth how each challenged claim is to be construed. *See* 37 C.F.R. § 42.104(b)(3). As discussed above, Petitioner’s contentions are limited to how the claim limitations at issue *should not be construed*. *See* Pet. 47. Petitioner does not set forth how the limitations directed to grasping members should be construed. Rather, “Petitioner does not believe any specific claim term of the Challenged Claims requires construction for the purposes of this petition and that every claim term should be given its ‘broadest reasonable construction in light of the specification.’” Pet. 4. Alternatively, Petitioner states “that this petition is based on the claim constructions urged by Patent Owner in the related district court litigation.” *Id.* at 5. Petitioner’s positions, however, do not set forth what the broadest reasonable interpretation of the limitations directed to grasping members is or set forth Patent Owner’s position in the related District Court litigation.

“Although” we recognize “there is no *per se* rule against negative constructions, *see Amgen Inc. v. Hoechst Marion Roussel, Inc.*, 314 F.3d 1313, 1329 (Fed. Cir. 2003),” our rules place an affirmative burden on petitioners to “set forth: . . . How the challenged claim is to be construed.” *Medicines Co. v. Mylan, Inc.*, 853 F.3d 1296, 1308 (Fed. Cir. 2017); 37 C.F.R. § 42.104(b)(3). This burden continues by requiring petitioners to adequately explain “[h]ow the *construed* claim is unpatentable.” 37 C.F.R. § 42.104(b)(4) (emphasis added). As explained below, the Petition fails to

identify how the challenged claims are to be construed and applied to the prior art, and Petitioner also takes conflicting positions between this proceeding and the related district court litigation. Specifically, in the related district court litigation, Petitioner advocated that the “grasping members” limitation be subject to means-plus-function claim construction. *K2M, Inc. v. OrthoPediatrics Corp. & OrthoPediatrics US Distribution Corp.*, Case No. 1:17-cv-00061-GMS (D. Del.) (Claim Construction Order 1). Given Petitioner’s prior factual and legal positions as to this term being subject to § 122 ¶ 6, Petitioner should have known that the question of whether or not the limitation directed to grasping members was likely to be at issue in this proceeding. Accordingly, Petitioner should have either provided reasons why these limitations are not governed by 35 U.S.C. § 112 ¶ 6, or Petitioner should have provided an explicit claim construction as required by our rules. Because of the unique circumstances of this proceeding, where Petitioner advocated for a different claim construction in the related district court litigation, we determine that construction of the claim termin dispute is necessary for the resolution of issues before us. Lacking such claim construction, the Petition fails to comply with 37 C.F.R. § 42.104(b)(3).

As noted above, Petitioner’s failure to provide a claim construction is, in this instance, further compounded by the fact that Petitioner takes an inconsistent position before the District Court, and the key limitation at issue has also tentatively been construed by the District Court as requested by Petitioner in that proceeding. As recognized by Petitioner, our claim construction has generally been informed by a district court’s claim construction, and we will continue to consider decisions of other tribunals

construing claim terms at issue. Pet. 6; *see also* “Changes to the Claim Construction Standard for Interpreting Claims in Trials Proceedings Before the Patent Trial and Appeal Board,” 83 Fed. Reg. 51340, 51355 (Oct. 11, 2018) (“The PTAB will consider prior claim constructions from courts or the ITC, if timely made of record, and give them appropriate weight.”) (effective Nov. 13, 2018, for newly filed proceedings). Keeping in mind that Petitioner has the burden to show a reasonable likelihood of prevailing in showing that at least one claim is unpatentable, it is incumbent upon Petitioner to address substantively the District Court’s claim construction of a limitation when construction of that limitation is likely to be a focal point of the *inter partes* review proceeding. By failing to reconcile its proffered claim construction here with its very different construction proffered in District Court—which the District Court agreed with—Petitioner fails to satisfy this burden.

III. CONCLUSION

Petitioner does not set forth a claim construction for the limitations directed to grasping members. By failing to set forth such a claim construction, the Petition does not show how the challenged claims are to be construed in accordance with 37 C.F.R. § 42.104(b)(3), and also does not show how, as so construed, they are unpatentable under the statutory grounds identified in the Petition. *See* 37 C.F.R. § 42.104(b)(4). Accordingly, Petitioner has not established a reasonable likelihood that it would prevail in showing the unpatentability of claims 1, 3, 5, 6, 8–10, 12, and 15–19 of the ’664 patent.

IV. ORDER

Accordingly, it is:

IPR2018-01546
Patent 9,655,664 B2

ORDERED that the Petition is *denied* as to the challenged claims of the '664 patent; and

FURTHER ORDERED that no *inter partes* review is instituted.

IPR2018-01546
Patent 9,655,664 B2

PETITIONER:

Paul M. Ulrich
Christopher A. Singh
Ulmer & Berne LLP
pulrich@ulmer.com
csingh@ulmer.com

PATENT OWNER:

Christopher Douglas
Michael S. Connor
Lauren E. Burrow
Christopher Ziegler
Brian D. Hill
Alston & Bird LLP
christopher.douglas@alston.com
mike.connor@alston.com
lauren.burrow@alston.com
chris.ziegler@alston.com
brian.hill@alston.com