

U.S. Patents No. 8,636,023



Specifications

Stock Number:	PAV-W PAV-WS (Supervised)
Service Pressure:	Up to 175 PSIG (12 Bar)
System Connection:	1/2" NPT Male
Temperature Range:	40°F - 120°F (4.5°C - 49°C)
Dimensions:	14"(L) X 7"(D) X 7"(H) (368mm(W) X 191mm(D) X 203mm(H))
Weight:	8 Lbs (3.6 Kg)
Clear Height:	5" (127mm)

- Patented redundant float design eliminates piping to a drain
- Support Hanger Not Required

General Description

The ECS Ejector Automatic Air Vent (PAV-W/WS) is a device that provides automatic venting of trapped air in wet pipe fire sprinkler systems. As a fire sprinkler system is filled with water, trapped air migrates to the high point of the system near the vent installation location which allows for trapped air to be vented. Trapped air contains oxygen which is the primary cause of corrosion in fire sprinkler systems. Corrosion in wet pipe fire sprinkler systems is directly proportional to the amount of oxygen trapped within the system piping, so a reduction in trapped air will in turn reduce the internal corrosion activity of the fire sprinkler system. Venting the trapped air in a wet pipe sprinkler system can also decrease water delivery time and reduce false water flow alarms.

The ECS Ejector Automatic Air Vent must be installed as shown on the engineering design documents, if a location is not provided install the vent at an accessible high point on the fire sprinkler system remote from the system riser where gas can be vented and at a location that the pressure gauge provided for visual monitoring can be viewed from directly below. The PAV-W/WS is also equipped with brass components that allows the device to be installed in areas subject to external corrosion. The float mechanism on the ECS Ejector Automatic Air Vent will automatically close when water reaches the vent and the redundant design eliminates the need to plumb the PAV-W/WS to drain. If the primary air vent valve allows any significant amount of water to leak past the second air vent valve will close preventing water from discharging and provide a system pressure reading on the pressure gauge. This condition will be an indication that the primary automatic gas vent valve has failed and requires service or replacement. The pressure gauge is designed to be visible from the floor below the ECS Ejector Automatic Air Vent from a distance of approximately 30 feet.

There are two available models of the ECS Ejector Automatic Air Vent: PAV-W and PAV-WS. The units both operate as described previously, but the PAV-WS includes a wiring connection to a monitoring circuit. A single contact rated 24VAC/DC @ 2A for electronic monitoring with an end of line resistor (EOLR) must be installed according to the wiring diagram in Figure 1 to electronically monitor the PAV-WS.

A notification from the PAV-WS indicates that the pressure switch on the bottom of the vent assembly has a system pressure reading due to a failure of the primary float valve which renders the ECS Ejector Automatic Air Vent inoperable.

Installation Instructions

1. The ECS Ejector Automatic Air Vent is equipped with an isolation ball valve to be connected to the fire sprinkler system. Once the PAV-W/WS has been assembled at the provided quick connect (see Figure 2), the contractor must install a 1/2" outlet (welded or mechanical) to connect the vent assembly to the sprinkler system.
2. Install the PAV-W/WS vent assembly at the location provided by the engineering design documents in a level position at an accessible high point on the sprinkler system where trapped gas can be vented.
NOTE: Piping to the vent assembly cannot be installed in a configuration that would trap water and prevent drainage to the sprinkler system; a water trap impedes the ability of the vent to remove gas from the fire sprinkler system.
3. When electronic supervision is specified the PAV-WS must be utilized instead of the PAV-W (see Figure 1) and an addressable monitor module with an end of line resistor must be provided in accordance with NFPA 72.
4. Inspection of the vent assembly should be performed after installation and hydrostatic testing of the fire sprinkler system. Inspection should be performed periodically thereafter in accordance with the applicable NFPA codes and standards and/or the authority having jurisdiction.

NOTE: Patented redundant float design eliminates piping the PAV-W/WS to a drain.

Operating Instructions

1. Once the fire sprinkler system has been hydrostatically tested, open the isolation ball valve on the PAV-W/WS. Trapped gas should be expected to immediately vent from the device if the system has been re-filled with water.
2. The isolation ball valve must remain in the open position to allow for venting of any additional trapped gas remaining in the system that may migrate to the vent location.
3. Plumbing the PAV-W/WS to drain is not required. Occasionally during venting operations a small amount of water may leak past the primary gas vent valve and collect in the intermediate plumbing. This is considered normal and not a failure of the valve.
4. Water traps that would restrict operation of the ECS Ejector Automatic Air Vent can be cleared by closing the isolation ball valve and removing the "Y" strainer plug. Once the water trap has been removed, replace the "Y" strainer plug and reopen the isolation ball valve.

Maintenance Instructions

1. The ECS Ejector Automatic Air Vent must be inspected annually at minimum.
 - a. Check the pressure gauge on the bottom of the vent assembly for a system pressure reading.
2. If a system pressure reading is detected the primary vent valve may require service or replacement.
 - a. While isolation ball valve is in the open position check for air/water leaks.
 - b. Close isolation ball valve to perform maintenance on the ECS Ejector Automatic Air Vent.
 - c. While isolation ball valve is in the closed position, inspection the "Y" strainer blockage, clean as necessary.
 - d. If replacement is required, contact Engineered Corrosion Solutions for replacement parts and instructions.

FIGURE 1 - Wiring Diagram

INSTALLATION NOTES:

1. If Monitored By The Building Fire Alarm System, Provide One Addressable Monitoring Module To Monitor The Ejector Automatic Air Vent.
2. Connect The Ejector Automatic Air Vent To The Addressable Monitoring Module.
3. Supervise The Circuit Using An End-Of-Line (E.O.L.) Resistor In

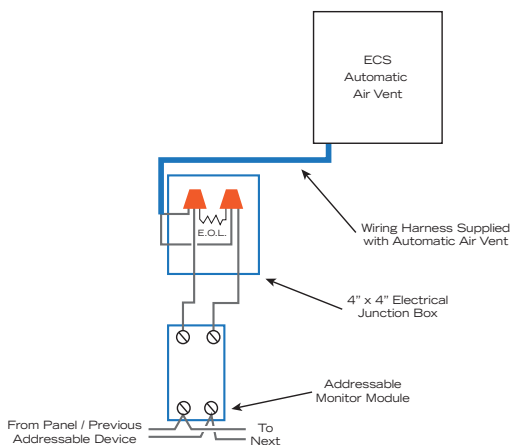

FIGURE 2 - ECS Ejector Automatic Air Vent Outline Drawing

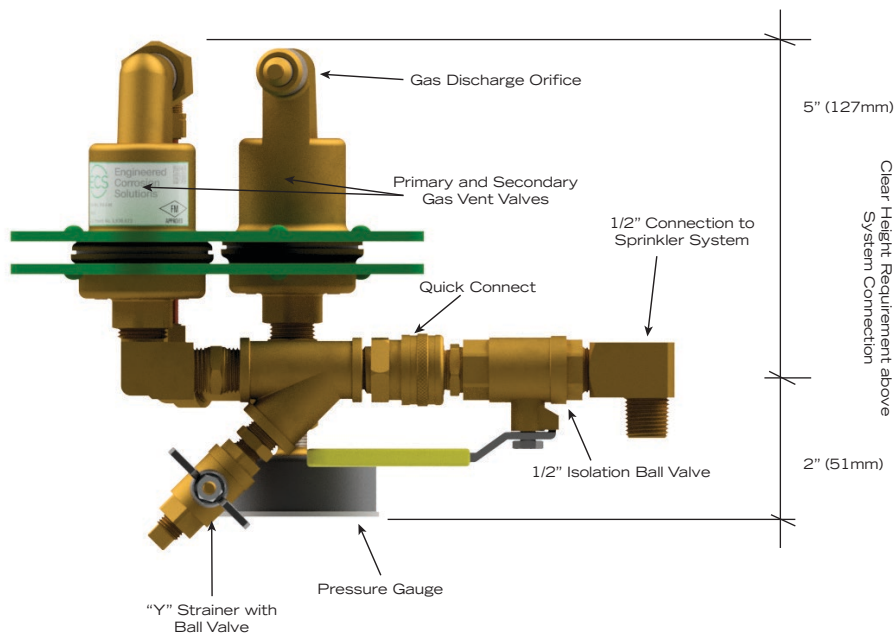
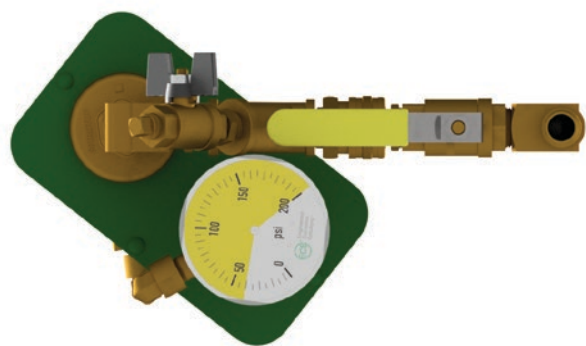
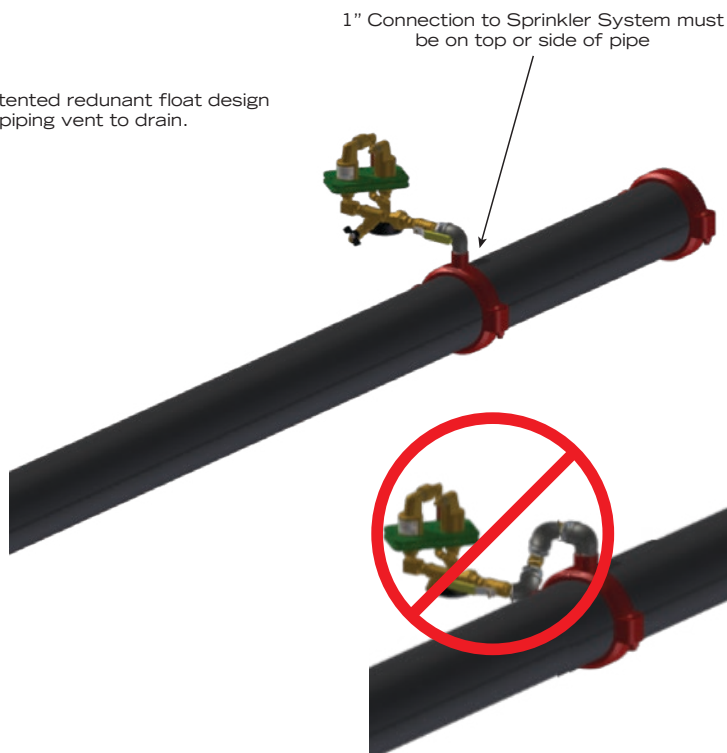

FIGURE 3 - ECS Ejector Automatic Air Vent Installed on Sprinkler System



NOTE: Patented redundant float design eliminates piping vent to drain.



NOTE: Piping to the vent assembly cannot be installed in a configuration that would trap water and prevent drainage to the sprinkler system; a water trap impedes the ability of the vent to remove gas from the fire sprinkler system.

OUR PRODUCTS. YOUR SYSTEMS.

Solutions for every environment

DRY PIPE SYSTEMS



Corrosion control technology located in the riser room.

WET PIPE SYSTEMS



Automatic air venting and nitrogen corrosion control.

MONITORING SOLUTIONS



Ensure effective corrosion control with real time corrosion monitoring solutions.

SERVICES



Corrosion assessments, pipe analysis, and long term corrosion control programs to mitigate future risk.

Dry Pipe System Nitrogen Generators

Corrosion control technology located in the riser room

	WALL MOUNT			SKID MOUNT	STAND ALONE W/ SEPARATE AIR COMPRESSOR			
	PGEN-3	PGEN-5	PGEN-10	PGEN-20	PGEN-30	PGEN-40	PGEN-50	PGEN-60
Total System Capacity	675 gal	950 gal	2,000 gal	3,200 gal	6,500 gal	11,000 gal	18,500 gal	22,500 gal
Single System Capacity @ 40 psi ⁽¹⁾	215 gal	265 gal	560 gal	950 gal	1,150 gal	1,440 gal	2,025 gal	2,900 gal
Single System Capacity @ 20 psi ⁽¹⁾	540 gal	590 gal	1,120 gal	1,800 gal	2,300 gal	2,880 gal	4,050 gal	5,800 gal
Air Compressor	Integral	Integral	Integral	Integral	Separate	Separate	Separate	Separate
Size (H x W x D)	36x24x9	36x24x9	38x29x11	57x32x40	53x24x9 ⁽²⁾	76x24x12 ⁽²⁾	76x24x12 ⁽²⁾	76x24x12 ⁽²⁾
Weight	115 lbs	125 lbs	175 lbs	420 lbs	152 lbs ⁽²⁾	264 lbs ⁽²⁾	300 lbs ⁽²⁾	300 lbs ⁽²⁾

NOTES:

- (1) Single system capacity based on 30 min. fill requirement of largest single sprinkler system; a secondary air compressor with normally closed isolation valve can be used to meet fill requirement for larger individual systems
- (2) Size and weight of nitrogen generator only, does not include separate air compressor
- (3) All nitrogen generators include one (1) year manufacturer's warranty per ECS terms and conditions