

INSTALLATION AND OPERATING INSTRUCTIONS

R-3F2-LXX

UL APPROVED FOR:
CLASS I, DIVISION 2 HAZ LOC
CAT III & IV

Part Number Description: The “XX” specifies the fiber-O cable length in inches.

General Usage: This 3-phase device reduces the risk of electrical arc flash into a HazLoc area by pre-verifying the electrical isolation from outside of a control panel. Engineered with redundant circuitry, the Voltage Indicator is powered by the same voltage that it indicates. The electronics housing is hardwired to the circuit breaker or main disconnect. A sleeved all plastic non-conductive fiber-optic cable passes light from the electronics housing to the separately mounted 30mm diameter "through-the-door" display adaptor, providing for a true “zero” voltage display. Grounding of the door then becomes un-necessary. Whenever AC or DC voltage is above detection thresholds the display indicators will flash or glow.

 **AVERTISSEMENT** La protection fournie par l'équipement peut être diminuée si l'équipement n'est pas utilisé de la façon spécifiée par le fabricant.

 **AVERTISSEMENT** - Risque de mort ou de blessure grave si un accident se produit : **POURRAIT**

BE SURE POWER IS SHUT OFF PRIOR TO INSTALLING THIS DEVICE!

Grace PESD® VOLTAGE INDICATOR R-3F2 UL NEC CLASS I, DIVISION 2 Patented

⚠ AVERTISSEMENT

DISPOSITIF AUXILIAIRE ADAPTÉ POUR UTILISATION EN CLASSE I, DIVISION 2 (ou ZONE 2), GROUPE A, B, C, D ZONES DANGEREUSES, ou ZONES NON DANGEREUSES SEULEMENT

Class I Groups:

- A** - acetylene
- B** - hydrogen
- C** - ethyl-ether vapors, ethylene or cyclopropane
- D** - gasoline, hexane, naphtha, benzene, butane, propane, alcohol, acetone, benzol, lacquer solvent vapors, or natural gas

Division 2 : Ignitable concentrations of gases, vapors, or liquids are not likely present under normal operating conditions

Haz Loc Normal Atmospheric Conditions: a) -25C to +40C ambient b) 21% Max. Oxygen concentration per volume c) barometric pressure range of 80 kPa (0.8 bar) to 110 kPa (1.1 bar)

⚠ AVERTISSEMENT



RISQUE D'EXPLOSION – NE PAS DÉCONNECTER L'ÉQUIPEMENT LORSQUE LE CIRCUIT EST SOUS TENSION OU À MOINS QUE LA ZONE NE CONTIENNE PAS DE CONCENTRATIONS INFLAMMABLES.

⚠ AVERTISSEMENT

RISQUE D'EXPLOSION – LA SUBSTITUTION DE TOUT COMPOSANT PEUT DIMINUER L'APTITUDE POUR LA CLASSE I, DIVISION 2

Approvals:

UL LISTED file No. E334957
 Per ISA 12.12.01-2007
 CAT REPORT No. E311256
 per UL61010-1, 3RD Edition
 CAN/CSA-C22.2 No. 61010-1, 3RD Edition

CAT III 1000V 
 CAT IV 600V 
 DC or AC-rms to Ground
 (Peak Impulse Transient 8000V
 20 repetitions, 2 ohm source)

CE 
 UL TYPE 4X
 TYPE 12
 TYPE 13
LISTED
 IND. CONT. EQ.
 HAZ. LOC. 42RV
 46RD

 - Double Insulation Symbol

Specifications:

Input: AC SINGLE OR 3-PHASE: 20 to 600V $3 \sim$, 50/60/400 Hz
 DC OR STORED ENERGY: 20 to 1000V $---$, (Voltages Line-to-Line or Line-to-Ground)

Maximum Rating: 750V $3 \sim$ or 1000V $---$ @ 1.2 Watts, Operating Ambient Air of 55°C Max.

Detection Thresholds: 14V $3 \sim$, 18.5V $1 \sim$, 15V $---$ (typical cut-off's)

Temperatures

Operate: -20C to +55C, Code T5
 Storage: -45C to +85C

Indicators: (8) Red Super Bright LED's

Terminations: (4) 6 ft, 18 AWG, 90°C @ 1000V, UL-1452 PVC insulation w/ nylon jacket
 L1- L3: Black w/ bar identification (Fig. 1) GND: Green w/ Yellow stripe

DIN Enclosure: Black Lexan, encapsulated including LEDs for environment protection

Display Adapter: Black Rynite, Fiber-O cable bundle fully encapsulated

Cable Sleeving: PET Flame Retardant braided sleeving, UL Category UZIQ2

O-Ring Seal: Blue VFMQ Florosilicone, UL approved material

R-3F2-L~~XX~~: Fiber-O standard cable length in inches (08, 12, 18, 24, 36, 48, 72)
 Minimum bend radius = 40mm

Fig. 1 Wire Identification

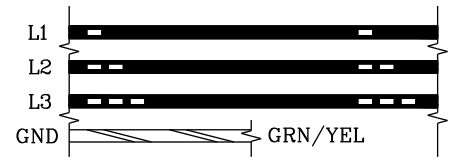

Environmental Ratings

Overvoltage Category: CAT III 1000 V & CAT IV 600 V per UL61010, 3RD Edition

Safety category ratings are important, differences and limitations are as follows:

CAT III 1000 V –rating allows up to 1000-V phase to ground with distribution level wiring, 480-volt and 600-volt circuits such as 3-phase bus and feeder circuits, motor control centers, load centers and distribution panels. Also included in CAT III are switchgear, motors, transformers and similar fixed loads, and loads that can generate their own transients.

CAT IV 600 V -rating means that it is suitable for use in all locations such as 3-phase utility or outdoor wiring on conductors that have up to 600-V phase to ground. Applications may include overhead or underground lines that power detached buildings or underground lines that power well pumps.

Transient Withstand: Both CAT III & CAT IV ratings are tested to withstand an 8,000-V transient overvoltage event from a 2 ohm source.

Pollution Degree: 2 - Equipment being evaluated to 60950, Laboratories, Test Stations, Office Environment

NEMA Enclosure designation: 4X -UL TYPE

Enclosures constructed for either indoor or outdoor use to provide a degree of protection to personnel against incidental contact with the enclosed equipment; to provide a degree of protection against falling dirt, rain, sleet, snow, windblown dust, splashing water, hose-directed water, and corrosion; and that will be undamaged by the external formation of ice on the enclosure.

Ingress Protection: IP66

First digit 6 = Dust-Tight. Second digit 6 = Protected against powerful water jets.

Operating maximum altitude: 5000 meters (UL's testing limit)

Humidity: 95% RH @ 1,000 hours

GND Indicators:

For isolated Delta or 3-Phase WYE applications, it is normal for the “GND” indicator pairs not to flash unless a phase is lost producing an unbalanced condition. This peculiarity results when the Phase-to-Phase voltages are balanced resulting in no current to a Neutral connection. The R-3F2 indicators are current driven; therefore, no net current in the R-3F2 ground line (connected to Neutral) will cause the “GND” indicators to not flash.

GND DETECTOR THRESHOLDS (LEAKAGE ANY PHASE-TO-GROUND)

3 ~ LINE-TO-LINE (VAC)	20	120	240	480	750
L1, L2, or L3 TO GND CONTINUITY (OHMS)	2M	5M	7.5M	13M	20M
DETECTOR INDUCED FAULT CURRENT (µA)	4	12	17	20	21

INDICATOR FLASH RATES (L1,L2,L3,GND)

3 ~ LINE-TO-LINE (VAC)	<14	20	120	240	480	600	750
FLASHES/SEC (TYPICAL)	0	0.9	2.6	3.3	3.7	3.8	3.9
--- OR STORED ENERGY (VDC)	<15	20	48	110	300	600	1000
FLASHES/SEC (TYPICAL)	0	0.9	1.9	3.2	3.7	4.0	4.0

INSTALLATION & OPERATING INSTRUCTIONS

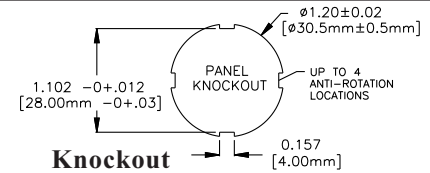

- 1.) Follow all Local, State, and National Electrical Codes when installing this equipment. Overcurrent protection of the supply leads may be necessary. When determined necessary, use a low .1A or .125A 600VAC fast acting fuse like KTK-1/10 or -1/8. The installation shall be used on a clean flat surface of a type 4X, 12, or 13 enclosure, or equivalent elevated ambient rating.
- 2.) The disconnecting means must first be suitably located and easily reached; and it must be marked as the disconnecting device for the equipment. The 30mm Display Adapter knock-out location must be in visual proximity to the control panel ON/OFF disconnect. Make sure to allow for enough fiber-optic cable length (part No. suffix 'XX' in inches) to properly route it back to the intended electronics housing's mounting location & orientation with all bends meeting the 40mm minimum bend radius. The universal mount housing location also must be installed within a 6 Ft. wire routing length to all monitored L1, L2, L3 and GND line connections.
- 3.) For the best sealing performance of the O-ring, verify the inside contact surface around the panel knockout is clean, flat and free of debris.
- 4.) For Delta configured power, connect the 1 bar, 2 bar & 3 bar printed black wires (Fig. 1, PG. 2) to L1, L2, & L3 respectively on the fused or disconnect side of the 3-Phase line voltage (Fig. 2, PG. 6). The Green/Yellow stripe (Grn/Yel) wire **MUST** be connected to Earth Ground.
- 5.) Wye configured power with grounded Neutral is connected the same as for Delta in step 4. The **GRN / YEL (GND)** wire **DOES NOT** connect to neutral but to Earth Ground.
Caution: The neutral will not be monitored for voltage by the Detector, only Phase-to-Phase and Phase-to-Ground voltage will be detected. To include neutral monitoring go the step 6.
- 6.) Ungrounded or high resistance Wye configured power requires 2 additional units to include Neutral monitoring. (See Fig. 4, PG. 7)
- 7.) For DC configured power wire as per Fig. 3, PG. 6.
- 8.) **Verifying Proper Operation:** *First disconnect all equipment that may introduce a hazard and notify personnel before powering the panel!*
TURN POWER ON. With up to 600V applied, the L1, L2, and L3 indicators should flash according to "FLASH RATE" Specifications above.
The type of power system grounding configuration determines if the GND indicator normally indicates (See **GND Indicators**, PG. 4).
- 9.) **TURN POWER OFF.** All indicators should be extinguished. **Note:** If only a single LED illuminates for any (2) indicator pairs, **STORED ENERGY** is likely present and must be removed or discharged.
All (8) indicators must be extinguished or a shock hazard is present on the monitored lines. Use this procedure to insure proper grounding:

To complete proper installation, verify grounding of the GRD lead-wire. Under normal operation, the power system determines if GRD LEDs illuminate.

- 1.) Apply power to the R-XXX, if the GRD LEDs do not illuminate, proceed to step 2.)
- 2.) Remove power and re-establish an electrical safe work condition to allow one phase lead-wire to be disconnected from its source by either disconnecting wire or pull a fuse.
- 3.) Re-apply power and verify that the GRD LEDs now illuminate to insure a proper ground connection.
- 4.) Complete installation by removing power and reconnecting the phase lead-wire or fuse and reapply power and re-verify that L1, L2, & L3 LEDs illuminate.

 **AVERTISSEMENT**

COUPER L'ALIMENTATION AVANT D'OUVRIER UN PANNEAU ! (Les étapes 1 à 9 servent d'abord à vérifier le bon fonctionnement des indicateurs.)
LES CONSIGNES DE SÉCURITÉ SONT TOUJOURS APPLICABLES : Avant de travailler sur un conducteur électrique, vérifier que l'énergie électrique est nulle à l'aide d'un instrument de détection de tension convenable et la procédure appropriée conformément à NFPA 70E 120.1(5), 120.2 (F)(2)(f)(1-6), OSHA 1910.333(b)(2)(iv)(B).

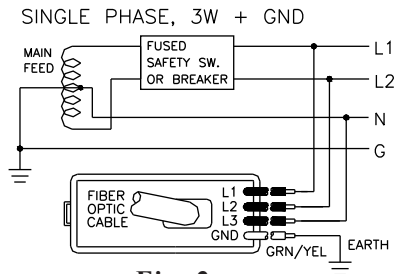
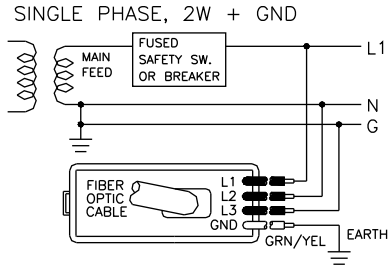
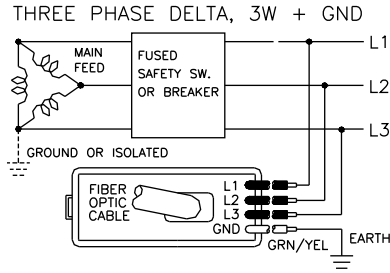
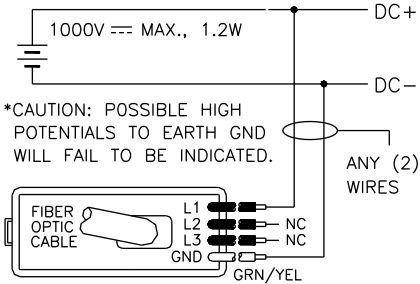

Fig. 2

DC SINGLE SOURCE, 2W ONLY
NON-SAFETY APPLICATION



DC SINGLE SOURCE, 2W + GND
SAFETY APPLICATION

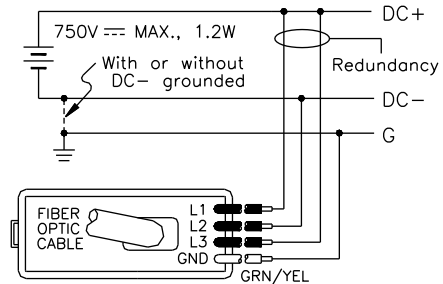

Fig. 3

3-PHASE WYE
4W + GND

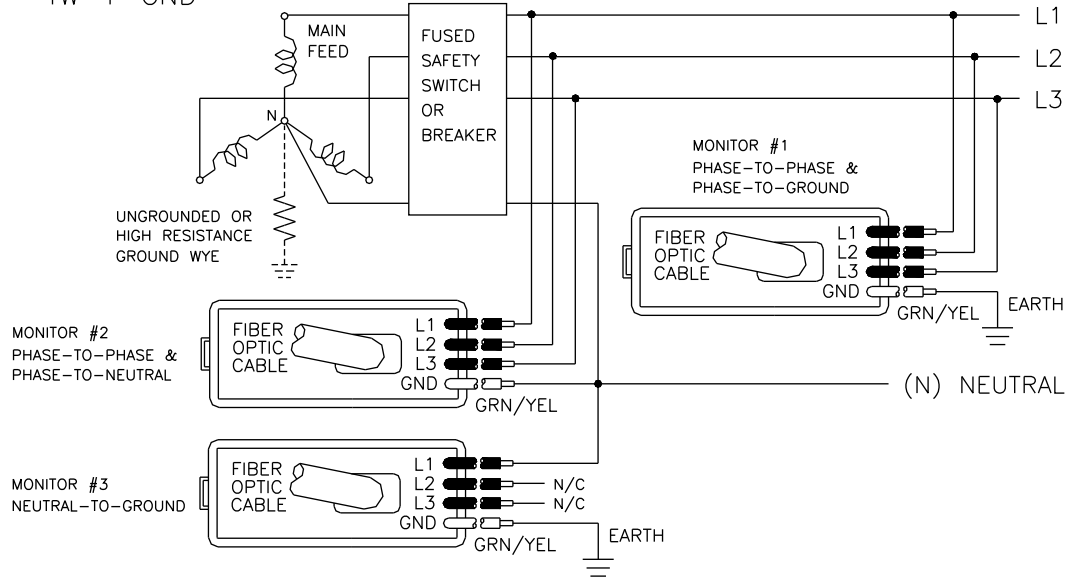
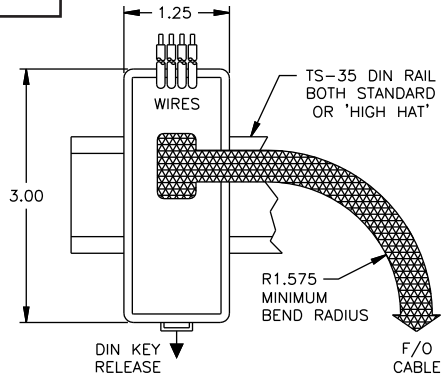
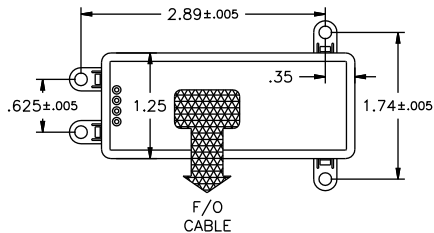

Fig. 4

Universal Mounting



DIN MOUNT Fig. 5



VERTICAL MOUNT Fig. 6

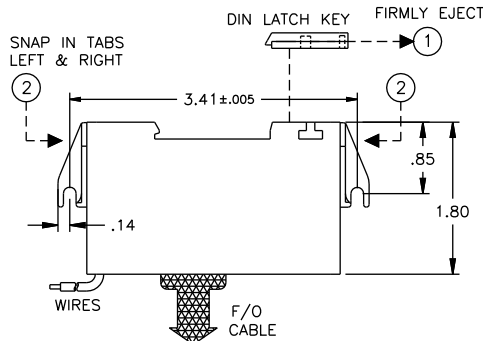

SIDE MOUNT Fig. 7

NOTE: Vertical or Side mount requires snap-in installation of respective mounting tabs (hardware included).



Part#: R-3W-L*

*These labels install around the R-3F2 with no affect on its UL certification. The labels are not UL approved.



Part#: R-3W-NP-F*

Fig. 8

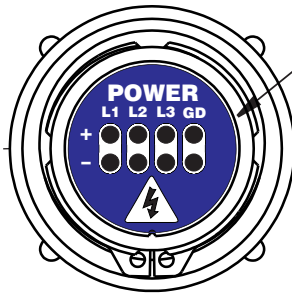
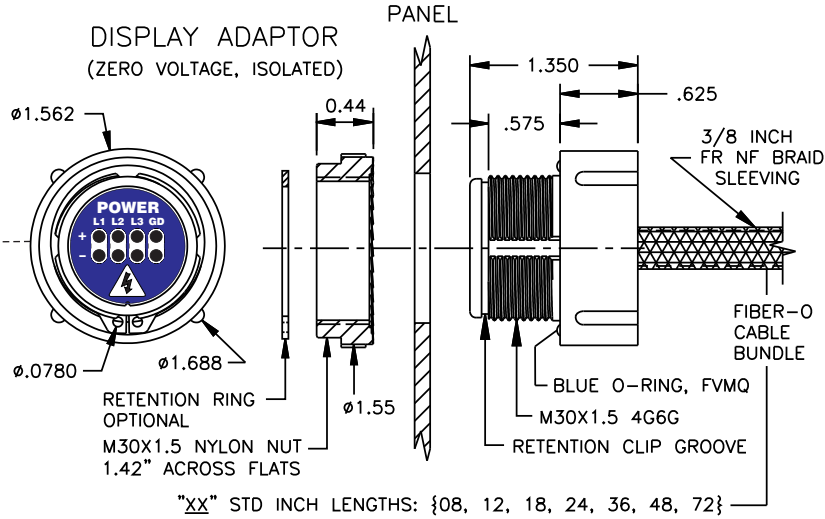

MAINTAIN A CLEAN DISPLAY LABEL BY GENTLY WIPING WITH A CLEAN DAMP CLOTH. ALL (8) INDICATORS MUST BE VIEWABLE FOR INDICATION.



- ATTENTION, possibilité de choc électrique

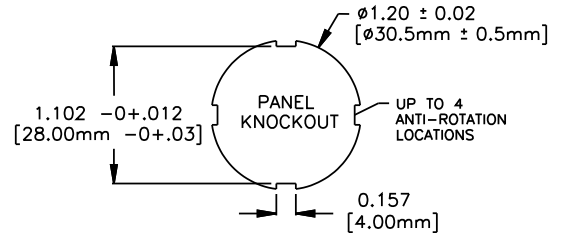
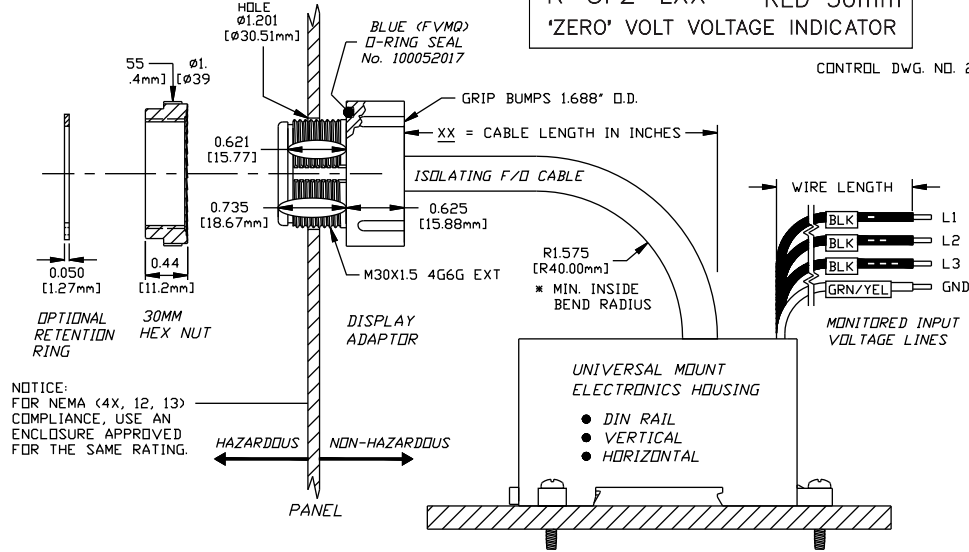

Fig. 9

R-3F2-LXX RED 30mm
'ZERO' VOLT VOLTAGE INDICATOR

CONTROL DWG. NO. 201



Installation Notes:

1. The inside mounting surface must be clean and smooth. Tighten the Hex nut until the grip flange contacts the panel surface so the O-ring is fully compressed. Do not overtighten.

Uninstalling for Inspection:

- ⚠ Avertissement : NE PAS INSTALLER L'APPAREIL À MOINS QUE L'ALIMENTATION AIT ÉTÉ DÉCONNECTÉE ET QUE LES ÉTAPES 1 à 9 DES INSTRUCTIONS D'INSTALLATION ET D'UTILISATION AIENT ÉTÉ PASSÉES EN REVUE.
- ⚠ Avertissement : L'EXPOSITION À CERTAINS PRODUITS CHIMIQUES PEUT DIMINUER LES PROPRIÉTÉS D'ÉTANCHEITÉ DU JOINT TORIQUE EN FLUOROSILICONE (FVMØ).
1. L'inspection périodique du joint torique est recommandée. Remplacer le joint torique si des signes de dégradation sont détectés.
 2. Pour le remplacement du joint torique, utiliser le numéro de pièce 100052017.
- ⚠ Avertissement : LA SUBSTITUTION DU JOINT TORIQUE EN FVMØ PEUT ANNULER LA CAPACITÉ À SATISFAIRE UL TYPE 4X, 12, 13.

⚠ - Indique un risque potentiel de blessure personnelle en cas de non-respect.

Weight (XX \ Kg): (08 \ .304), (12 \ .309), (18 \ .317), (24 \ .325), (36 \ .341), (48 \ .357), (72 \ .389)

Notes:

1. XX =Model No. suffix, cable length in inches
2. includes mounting hardware, excludes packing materials

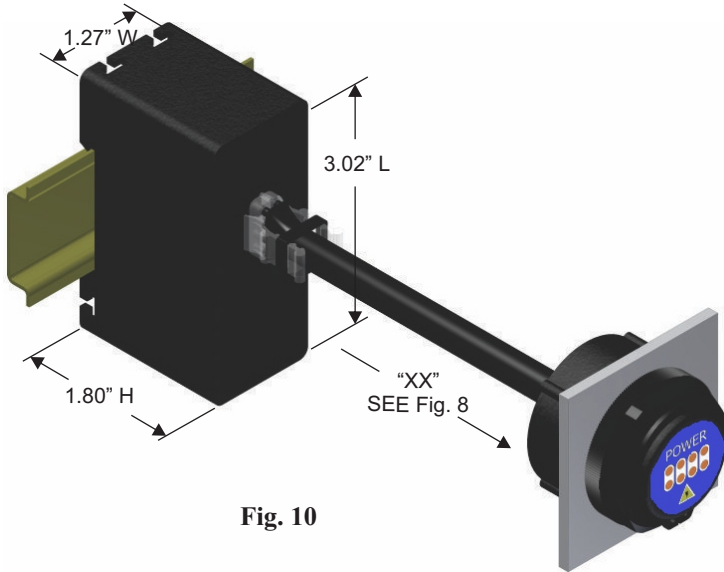

Fig. 10

INSIDE THE BOX

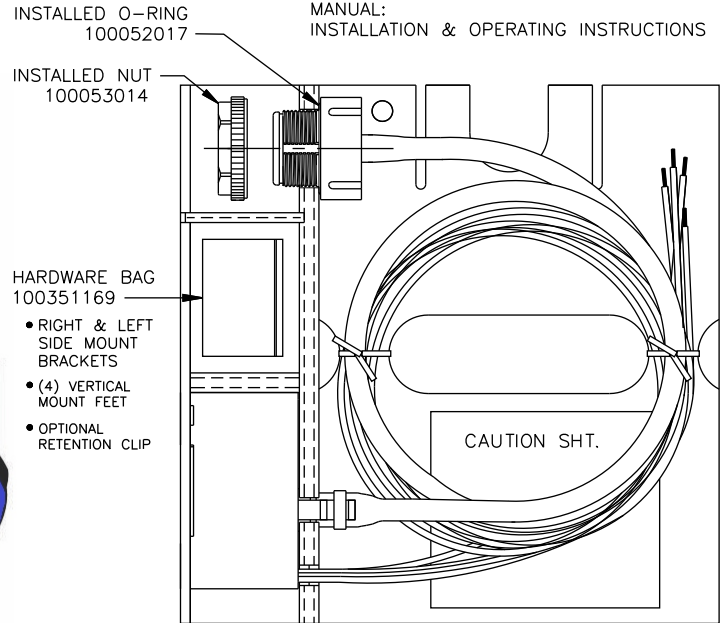

Fig. 11

