

Instructions for Installing HMI Cover

NOTE: Phillips Screwdriver or similar tool is required to install cover.

1. Place frame on a flat smooth surface and mark hole locations and panel opening.
2. Drill or cut holes 7/32 or #2 (.220 Dia) and opening accordingly. (Prior to mounting, clean surface and gasket of debris.)
3. Mount HMI Cover with supplied mounting hardware. Hardware applicable to mounting surface thickness of .059" - .250". Hardware torque specification 15 - 20 in-lbs.
4. Hardware kit includes:
 - 70-10321 quantity 10. 10-32 X 1 Pan Head Machine Screw.
 - 70-EMRWASHER quantity 10. Stainless Steel Washer Rivet.
 - 55-1032 quantity 10. Nut 10-32 With Nylon Insert.

PART NUMBER	NUMBER OF KITS	MAX PANEL CUTOUT SIZE (IN.)		NUMBER OF FASTENERS NEEDED
		H	W	
H-X-YD7	1	8.47	6.69	8
H-X-YA7	1	10.47	8.69	8
H-X-YC7	1	12.49	10.71	10
H-X-YE7	1	14.49	12.71	10
H-X-YF7	2	18.49	14.71	18

May include extra hardware depending on HMI frame size.

Note: Part includes feature on latch that may be used to prevent unauthorized or unintentional opening of the latches. Padlock sold separately.

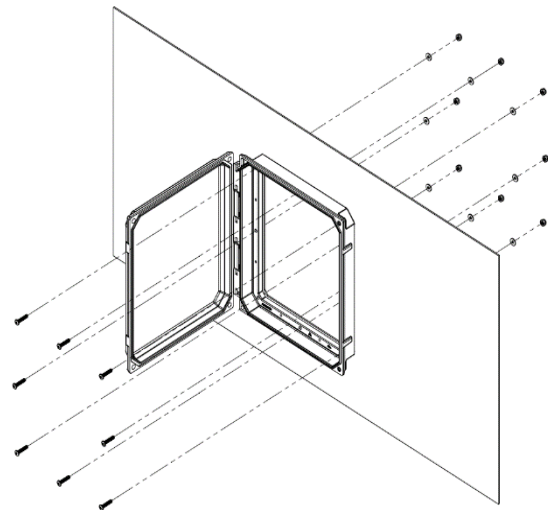
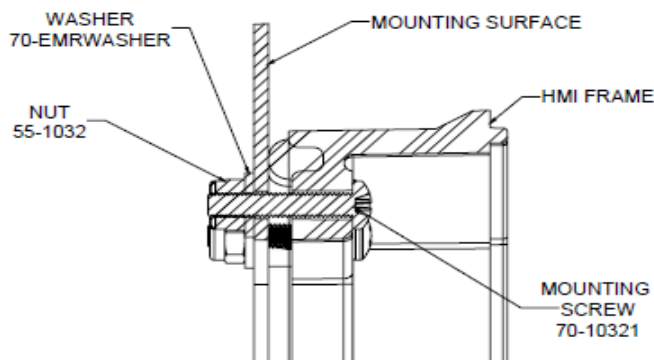

Grace Engineered Products, Inc.

1515 E. Kimberly Road • Davenport, Iowa 52807

Phone: 1-800-280-9517 • www.graceport.com

Email: sales@grace-eng.com