

SAFE-TEST POINT™

HIGH IMPEDANCE TECHNICAL NOTE

Safe-Test Point™ is a high impedance device with the primary purpose of indicating presence and absence of voltage. **Safe-Test Point™** is designed with metered test points to allow for safe voltage measurement from outside the panel by inserting properly rated instrument probes into the device measuring phase-to-phase and phase-to-ground. The voltage values will read with a percentage of error that varies depending on the ratings and series of the multimeter. For example, when measuring voltage on 480VAC system Phase L1 to Phase L2, the 10MΩ multimeter voltage value will have a -2% reduction reading approximately 470V.

While combining the **Safe-Test Point™** with the R-3W voltage indicator, this adds additional indication of voltage presence or absence that can be incorporated into a facility's Lockout/Tagout (LOTO) program, increasing qualified personnel safety and productivity.

These devices enhance compliance to NFPA 70E & CSA Z462. Always follow the "live-dead-live" test procedure as mandated by OSHA & NFPA 70E (2015), Article 110.4(A)(5), 120.1, Annex G and CSA Z462. See below for a sample procedure.



SAMPLE PROCEDURE

- 1) Verify the test instrument is calibrated and properly rated for application.
 - 2) Verify the test instrument to a known voltage source.
 - 3) Verify there is voltage illumination on the voltage indicator.*
 - 4) Open the dust cap and insert the test instrument probes into the test point and measure the voltage between phase to phase and phase to ground to verify voltage presence.
 - 5) Open Isolator.
 - 6) Verify there is no LED illumination on the voltage indicator.*
 - 7) Re-insert the Test Instrument probes into the test point and measure the voltage between phase to phase and phase to ground to verify voltage absence.
 - 8) Re-verify test Instrument to a known voltage source.
 - 9) Upon completion of work, close the dust cap on the test point, close isolator, and verify proper operation of voltage indicator.
- *If used with a voltage indicator.
- Note: The voltage accuracy of the test point is -2% and the test instrument will read small mV due to the high impedance circuit in the test points.*

HOW TO CALCULATE EXPECTED READING OF VOLTAGE MEASUREMENTS WITH YOUR MULTIMETER

Step 1 – Obtain multimeter impedance, can be typically found in manufactures manual listed under Specifications Input Impedence (Grace Engineered Products recommends using CAT III/IV 10MΩ multimeter)

Step 2 – Resistance Calculation (Meter R / Sum R)

Step 3 – Calculate Reduction Voltage (Resistance Calculation * Voltage of system).

- a) Phase to Phase
- b) Phase to Ground

(See examples on back)

CALCULATIONS

Calculated Voltage = (Meter R / Sum R) x V

Where,

Meter R = Multimeter Impedance

Sum R = Internal resistance of Safe-Test Point + Meter R

V = System Voltage

Example 1: (refer to Figure 1a & 1b)

Using a 10MΩ Multimeter; Measuring Voltage Phase L1 to Phase L3 and Phase to Ground on a 480Y/277V System

Example 1 Calculations:

Calculated Reduction Voltage = (Meter R / Sum R) x V

Step 1 – Meter R = 10MΩ

Step 2 – Resistance Calculation (Meter R / Sum R)
 $= 10M\Omega / (102K\Omega + 102K\Omega + 10M\Omega)$
 $= 0.98$

Step 3a – (Meter R / Sum R) x V (Where, V = 480V)
 $= 0.98 \times 480$
 $= 470.4V$

Step 3b – (Meter R / Sum R) x V (Where, V = 240V)
 $= 0.98 \times 277$
 $= 271.5V$

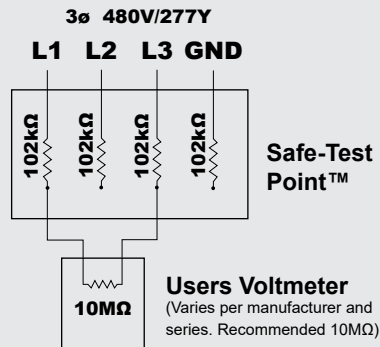

Figure 1a

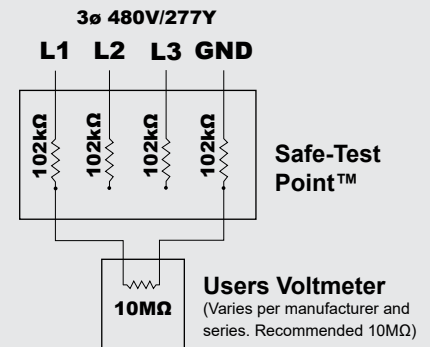

Figure 1b

Example 1 Results:

480Y/277V system measured using Safe-Test Point™ and 10MΩ multimeter will have a -2% reduction voltage reading. Phase to Phase voltage reading will be approximately 470V, and Phase to Ground voltage reading will be approximately 271.5V

Example 2: (refer to Figure 2a & 2b)

Using a 1MΩ Multimeter; Measuring Voltage Phase L1 to Phase L3 and Phase to Ground on a 480/240V Delta System

Example 2 Calculations:

Calculated Reduction Voltage = (Meter R / Sum R) x V

Step 1 – Meter R = 1MΩ

Step 2 – Resistance Calculation (Meter R / Sum R)
 $= 1M\Omega / (102K\Omega + 102K\Omega + 1M\Omega)$
 $= 0.83$

Step 3a – (Meter R / Sum R) x V (Where, V = 480V)
 $= 0.83 \times 480$
 $= 398V$

Step 3b – (Meter R / Sum R) x V (Where, V = 240V)
 $= 0.83 \times 240$
 $= 199.2V$

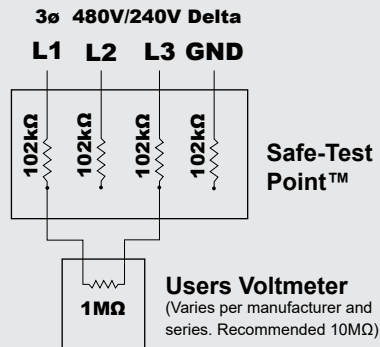

Figure 2a

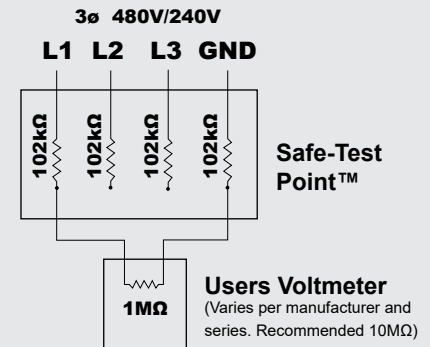

Figure 2b

Example 2 Results:

480/240V Delta System measured using Safe-Test Point™ and 10MΩ multimeter will have a -17% reduction voltage reading. Phase to Phase voltage reading will be approximately 398V, and Phase to Ground voltage reading will be approximately 199.2V

3 Phase Systems	10MΩ Multimeter		1MΩ Multimeter		500kΩ Multimeter	
	-2% Voltage Reduction		-17% Voltage Reduction		-29% Voltage Reduction	
	Phase to Phase	Phase to Ground	Phase to Phase	Phase to Ground	Phase to Phase	Phase to Ground
208Y/120V	203.8	117.6	172.6	99.6	147.7	85.2
480Y/277V	470.4	271.5	398.4	229.9	340.8	196.7
600Y/374V	588.0	340.1	498.0	288.0	426.0	246.4
240/120V Delta	235.2	117.6	199.2	99.6	170.4	85.2
480/240V Delta	470.4	235.2	398.4	199.2	340.8	170.4