

INSTALL A 3" LONG PIECE OF 3/8" PLASTIC TUBING PRIOR TO SPLICING

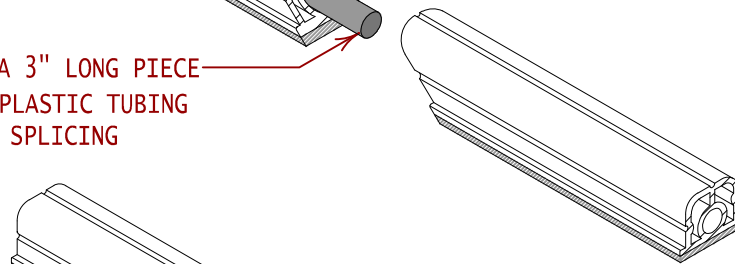

HEAT THE SPLICE JOINTS AND SLIDE THE TWO PIECES TOGETHER ON A FLAT SURFACE

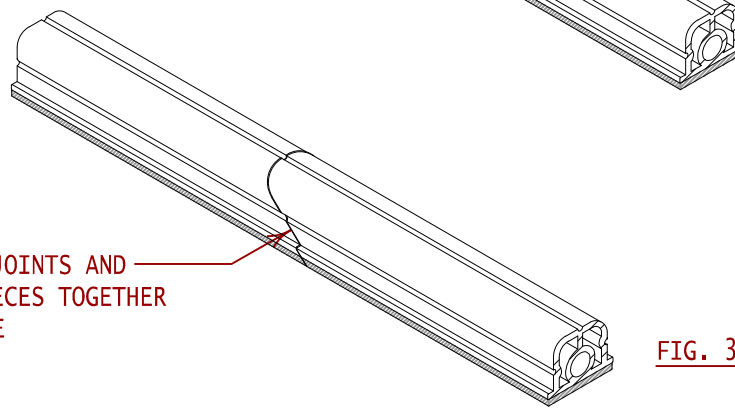

GENERAL REFERENCE:
"FTR GS 02/13"
APPLICABLE SYSTEMS:
"FTR SMRP 02/13"

SIMULATED METAL RIB PROFILE SPLICE ("SMRP" SIMULATED METAL RIB PROFILE)

REVISES DETAIL	ISSUE DATE	DRAWING NUMBER
ALL PREVIOUS	02-10-14	FTR-SMRP2