



THE K FACTOR: A NEW MATHEMATICAL TOOL FOR STABILITY ANALYSIS AND SYNTHESIS

H. Dean Venable • Venable Industries



VENABLE
instruments

THE K FACTOR: A NEW MATHEMATICAL TOOL FOR STABILITY ANALYSIS AND SYNTHESIS

H. Dean Venable
Venable Industries, Inc.
2120 W. Braker Lane, Suite M
Austin, TX 78758
info@venableind.com
<http://www.venableind.com>

Abstract

Analysis of the stability of feedback loops has always been a subject that was shrouded in mystery and confusion. Recent efforts to clear away some of these problems have helped, but even with computer-aided design, a certain amount of trial-and-error remained. This paper presents a new mathematical concept that is simple but powerful. The techniques described allow synthesis of a feedback amplifier with a few algebraic equations to obtain any desired crossover frequency and phase margin (within reason) on the first try.

1. INTRODUCTION

Stability analysis of feedback loops has historically required a certain amount of trial-and-error. Computer modeling and computer-aided design allowed one to evaluate results of a particular design with relative ease, but it was still difficult to start with a designed result and then determine the exact circuit values required to obtain that result. This paper presents three standardized feedback amplifiers which cover the requirements for every known loop. These amplifiers, together with a new mathematical concept called the K Factor, allow the circuit designer to choose a desired result, i.e., a particular loop cross-over frequency and phase margin, and then determine the necessary component values to achieve these results from a few straight-forward algebraic equations.

Venable Industries, Inc. specializes in the sale and support of computer-controlled Frequency Response Analyzer test systems designed for the power supply industry. Written in 1983, the *K Factor* paper is a mathematical convention that led us to our current product capabilities.

Today, Venable's software instantly designs all of the compensation values for this circuit topology and others, automatically calculating values based on test or model data. This feature saves valuable design time. It enables engineers to quickly and accurately measure the frequency response of components and analog circuits as well as test impedance across the frequency domain. Most importantly, the Venable Frequency Response Analyzer system allows engineers to optimally stabilize feedback loops.

2. THE NATURE OF LOOPS

A typical loop is shown in Figure A1. The loop consists of a power-processing block called a MODULATOR in series with an error-detecting block called an AMPLIFIER.

The modulator can be as simple as the buck regulator shown, or it could have been a complex hydraulic servo system or an aircraft attitude control system. No matter how complicated the modulator, the principle is the same:

Reference Reading # 4

a portion of the output is compared to a reference in an error amplifier, and the difference is amplified and inverted and used as a control input for the modulator to keep the controlled variable constant. Even in multiple-loop systems, there is still one main loop that performs this function.

3. WHAT STABILITY MEANS

3.1 The Nature of Stability

There is no problem with a control loop at DC. It is obvious that negative feedback tends to make the controlled output more constant. The problem comes at some higher frequency. Reactive components and time delays cause phase shifts which tend to increase the phase shift around the loop. There is a 180 degree phase shift at DC. At some frequency, the additional phase shift from reactive components and time delays is equal to 180 degrees also, so that an error signal at this frequency will be shifted a total of 360 degrees as it progresses around the loop, and comes back in phase with the original signal. If the net of all the amplitude gains and losses around the loop is one or greater at this frequency, then the error signal is self-perpetuating and the circuit becomes an oscillator. The object of stability analysis is to find a way to keep the total

phase shift from reaching 360 degrees before the loop gain falls below unity (0 dB). This is shown graphically in Figure A2. The difference between the actual total phase shift and 360 degrees when the gain is unity is called PHASE MARGIN. The amount the gain is below unity when the total phase shift reaches 360 degrees is called GAIN MARGIN.

3.2 The Importance of Phase

It is possible to stabilize a loop just by reducing the gain of the amplifier until loop cross-over occurs at a frequency well below that where phase shifts from reactive components start to become significant. The problem with this approach is that the response time of the loop to a transient disturbance is slowed down to the point where it is usually unacceptable. In any high-performance loop, the object is to cross over at as high a frequency as possible, while maintaining good phase margin. This is accomplished by tailoring the frequency response of the error amplifier to compensate for some of the modulator phase shift in the region of gain cross-over. A principle objective of this paper is to examine the nature of this "tailoring," and to derive equations that allow loop performance to be predicted without iterative "trial-and-error" procedures.

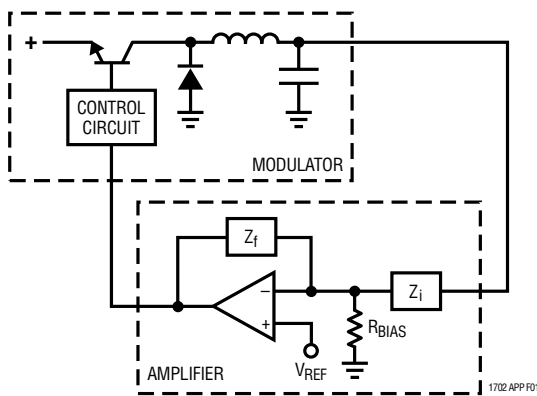

Figure A1. Closed Loop Circuit

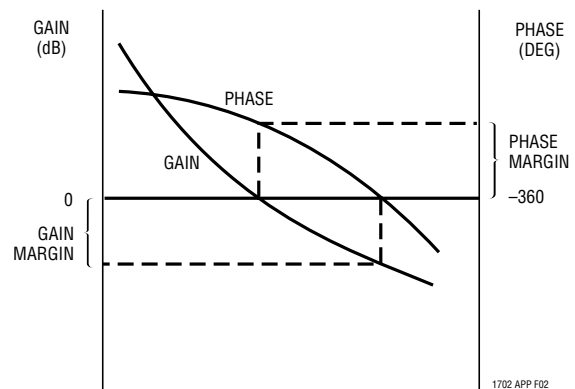

Figure A2. Stability Criteria

4. THE NATURE OF MODULATORS

The modulator, or power-processing portion of a circuit, can take many forms. Because of the general nature of modulators, each one has to be analyzed individually. In switching power supplies, however, the transfer function of the modulator usually takes one of two forms: either buck-derived or boost-derived.

4.1 Buck-Derived Modulators

Figure A3 shows a typical transfer function of a buck-derived modulator. An electrical transfer function of a circuit is the output voltage divided by the input voltage, with both the magnitude and phase angle of this ratio plotted as a function of frequency. In buck-derived switching regulators with L-C filters, the transfer function usually has some fixed value, A_V , at low frequency, associated with minimal phase shift. At the resonance of the L-C filter, the transfer function breaks to a -2 slope (a -1 slope falls 20 dB/decade, a -2 slope falls 40 dB/decade, etc.). A -2 slope is associated with -180 degrees of phase shift. At some frequency (usually, but not always, higher than the frequency of the L-C corner) the internal resistance of the filter capacitor (ESR) becomes higher than the capacitive reactance, and the slope of the transfer function curve changes to -1 as the filter changes from an L-C filter to an L-R filter. The phase shift associated with a -1 slope is -90 degrees, provided the response is determined by real components.

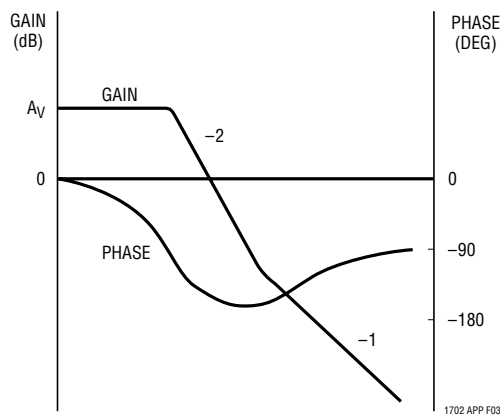

Figure A3. Transfer Function of Buck Modulator

4.2 Boost-Derived Modulators

Figure A4 shows the transfer function of a boost-derived modulator. The gain portion of a boost-derived modulator looks very much like the gain portion of a buck-derived modulator. There are some major differences in the gain portion, however, and the phase portion is obviously different. Most boost-derived modulators also have a region of fixed gain at low frequency, again associated with a minimal phase shift; however the value of gain in this region is usually a non-linear function of operating point. There is a point in frequency where the transfer function breaks to a -2 slope, as in the buck-derived case, but this frequency is also a function of operating point because the effective value of inductance changes with duty cycle. The phase shift associated with the -2 slope region is the same in either case, -180 degrees. The major problem in boost-derived modulators is caused by a right-half plane zero, a mathematical entity that nevertheless causes real problems. The frequency at which the right-half plane zero occurs is related to the effective value of the filter inductance and the load resistance, and usually occurs at a low enough frequency (typically several kilohertz) that the effect of it must be considered when trying to optimize loop performance. A right-half plane zero causes the gain curve to break from a -2 to a -1 slope, the same as a left-half plane zero, but the phase shifts 90 degrees negative instead of positive. No practical amplifier offers enough phase boost to compensate

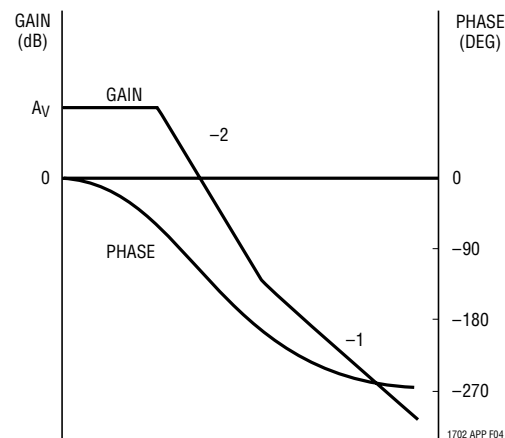

Figure A4. Transfer Function of Boost Modulator

Reference Reading # 4

for this phenomenon, so modulators with boost-derived transfer functions are restricted to cross-over frequencies below the frequency of the right-half plane zero. Recently, Dr. Fred Lee and others have proposed techniques generally referred to as “multiple-loop feedback” methods, wherein a signal from the energy storage inductor is fed into the pulse width modulator circuit to change the basic transfer function of the modulator, eliminating the right-half plane zero, and even reducing the -2 slope portion of the modulator to a -1 slope by using current feedback. These modifications are very helpful in obtaining good performance from boost-derived modulators by changing the basic nature of their transfer functions, but do not change the basic techniques described herein for stabilizing loops. No matter what type of modulator is used, or what modifications are incorporated to change the modulator transfer function, the techniques for stabilization of the loop are exactly the same. One of the three basic amplifiers described below will still suffice to stabilize any loop.

5. THE THREE BASIC AMPLIFIERS

5.1 Fundamental Assumptions

In all cases, it is assumed that a real op-amp is used and that the system is configured so that negative feedback (inversion) is required in the amplifier. It is possible to stabilize loops using the internal error amplifier provided in most PWM chips, but it is difficult to optimize performance since the transfer function is generally based on internal component values which are poorly specified and therefore unpredictable. It is also possible, although difficult, to stabilize loops using an error amplifier in the non-inverting mode. The trouble with this mode is that the gain is restricted to values greater than one, and this is not always compatible with the desired transfer function of the amplifier. For best performance, the internal amplifier of the PWM chip should be wired as an inverting or non-inverting buffer, whichever allows the external error amplifier to be inverting. For the SG1524 family of chips, for example, the internal amplifier should be wired as a non-inverting buffer for positive output voltages and as an inverting buffer for negative output voltages. For the

TL494 family of chips, which have the opposite internal sense, the internal amplifier should be wired as an inverting buffer for positive output voltages, and as a non-inverting buffer for negative output voltages.

5.2 Type 1 Amplifier

Figure A5 shows a Type 1 amplifier and its transfer function. The Type 1 amplifier has a single pole at the origin and the gain rolls off at a -1 slope forever, crossing unity gain at the frequency where the reactance of $C1$ is equal in magnitude to the resistance of $R1$. This type of amplifier has -270 degrees of phase shift throughout the -1 slope region, and is used to compensate loops where the phase shift of the modulator is minimal, for example, below the L-C filter corner.

5.3 Type 2 Amplifier

Figure A6 shows a Type 2 amplifier and its transfer function. The Type 2 amplifier also has a pole at the origin, but has a zero-pole pair in addition. This zero-pole pair causes a region of zero gain slope and a corresponding phase “bump”, or region of reduced phase shift. Whereas the phase shift is -270 degrees throughout the -1 slope regions of the amplifier transfer function, in the zero slope region the phase shift tends toward -180 degrees. The amount of phase shift reduction (size of the “bump”) is related to the width of the zero slope region and has a maximum value of 90 degrees. The frequency at which the zero occurs is approximately that where $R2$ takes out $C1$, that is, where the reactance of $C1$ is equal in magnitude to the resistance of $R2$. The frequency at which the pole occurs is approximately that where $C2$ takes out $R2$, that is, where the reactance of $C2$ is equal in magnitude to the resistance of $R2$. Type 2 amplifiers are used to compensate loops where the phase shift of the modulator portion is approximately -90 degrees. The transfer function of the amplifier is designed so that overall loop cross-over occurs in the center of the zero gain slope region. The zero-pole pair is frequently referred to as a “lead” network. Notice that the output of an amplifier can never lead the input, and that a “lead” network can be more accurately described as a “reduction in lag” network.

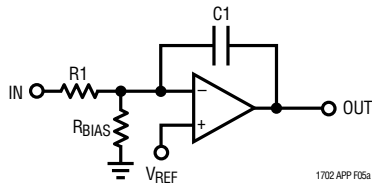

Figure A5a. Type 1 Amplifier Schematic Diagram

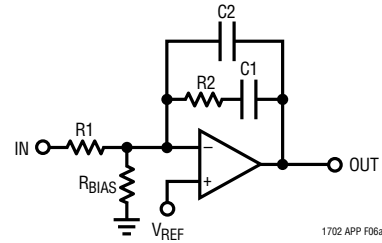

Figure A6a. Type 2 Amplifier Schematic Diagram

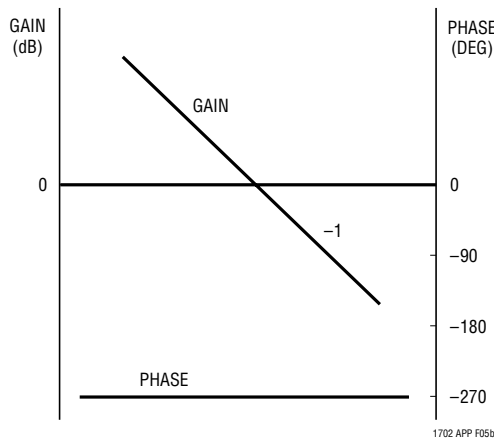

Figure A5b. Type 1 Amplifier Transfer Function

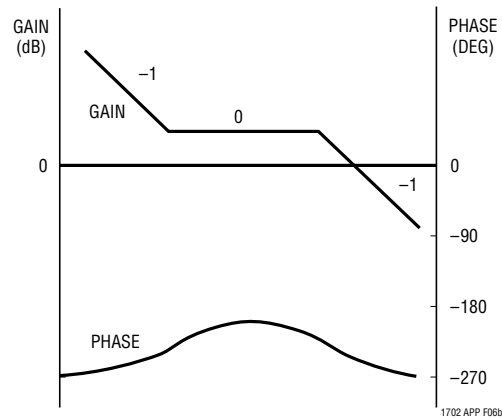

Figure A6b. Type 2 Amplifier Transfer Function

5.4 Type 3 Amplifier

Figure A7 shows a Type 3 amplifier and its transfer function. A Type 3 amplifier also has a pole at the origin, but in addition has two zero-pole pair. The two zeros are coincident and the two poles are coincident, resulting in a region of +1 gain slope and a corresponding phase “bump”, or region of reduced phase shift. Whereas the phase shift is -270 degrees throughout the -1 slope regions of the amplifier transfer function, in the $+1$ slope region the phase shift tends toward -90 degrees. The amount of phase shift reduction (size of the “bump”) is related to the width of the $+1$ slope region, and has a maximum value of 180 degrees. The frequency where the two zeros occur is approximately where $R2$ takes out $C1$ and $C3$ takes out $R1$, and the frequency where the two poles occur is approximately where $C2$ takes out $R2$ and $R3$ takes out $C3$, where

“takes out” means the capacitive reactance is equal in magnitude to the resistance. Type 3 amplifiers are used to compensate loops where the phase shift of the modulator portion is approximately -180 degrees at the frequency of desired loop gain cross-over. The transfer function of the amplifier is designed so that overall loop cross-over occurs in the center of the $+1$ slope region. Type 3 amplifiers have the most phase boost of any practical amplifier configuration. It is not practical to compensate for more than 180 degrees of phase lag in the modulator portion. If the phase shift of the modulator at the chosen cross-over frequency is greater than 180 degrees, steps should be taken to cross the loop over at a lower frequency (frequency with less phase lag), or modify the modulator circuit to reduce the amount of phase lag at the desired cross-over frequency.

Reference Reading # 4

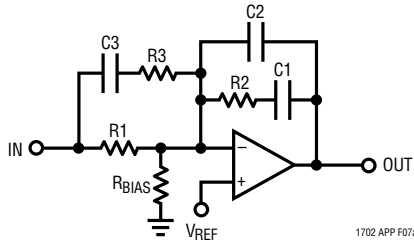

Figure A7a. Type 3 Amplifier Schematic Diagram

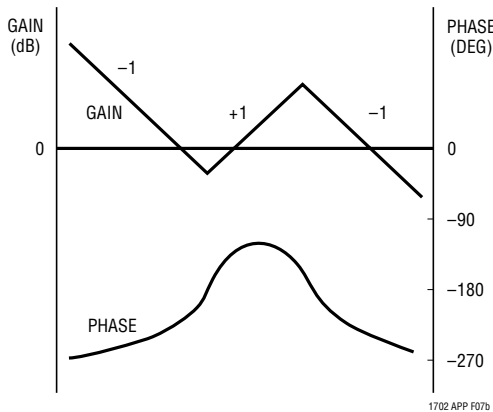

Figure A7b. Type 3 Amplifier Transfer Function

6. THE K FACTOR

6.1 Introduction to the K Factor

The K Factor was originally conceived of as an aid in the synthesis of amplifiers. It is defined as the square root of the ratio of the pole frequency to the zero frequency for Type 2 amplifiers, or the ratio of the double pole frequency to the double zero frequency for Type 3 amplifiers. Figure A8 shows the relationship between the loop cross-over frequency, f , and location of the zeros and poles of the amplifier transfer function. Type 1 amplifiers always have a K of 1. A Type 2 amplifier has a zero at f/K and a pole at Kf , therefore f is the geometric mean of the zero frequency and the pole frequency. The peak phase boost from the zero-pole pair occurs at frequency f , and it is assumed that the amplifier is designed so that overall loop cross-over

occurs at frequency f also. For a Type 3 amplifier, the frequency of the double zero is f divided by the square root of K and the frequency of the double pole is f times the square root of K . Frequency f is then the geometric mean between the frequency of the double zero and the frequency of the double pole. The peak of the phase boost from the two zero-pole pair occurs at frequency f , and it is assumed that the amplifier is designed such that the overall loop cross-over occurs at frequency f also. In each case, the larger the K , the larger the phase boost.

6.2 Tradeoffs of K Factor Value

There is a penalty associated with using zero-pole pair to increase phase margin that is evident from looking at Figure A8. No matter what type of amplifier is chosen, the K factor is a direct measure of the reduced gain at low frequency and increased gain at high frequency which result from the zero-pole pair, both undesirable side effects of the quest for more phase margin. The K factor can then be thought of the gain penalty that is paid for increased phase margin.

6.3 f/K as a Figure of Merit

To improve overall loop performance, one's first thought is to increase the loop cross-over frequency. If this increase happens to coincide with a frequency range where the modulator phase lag is increasing rapidly, K may have to be increased faster than f to maintain the same phase margin, in which case the low frequency gain will actually suffer from the increased cross-over frequency. The expression f/K can therefore be thought of as a Figure of Merit for a particular amount of phase margin.

7. DERIVATION OF THE K FACTOR

The Type 1 amplifier always has a K of 1, so deriving the K factor for it is not a problem. Also, the mathematics for determining the amount of boost from given locations of amplifier zeros and poles is well understood. The problem that had not been solved was to derive equations that expressed the location of the zeros and poles as a function of phase boost.

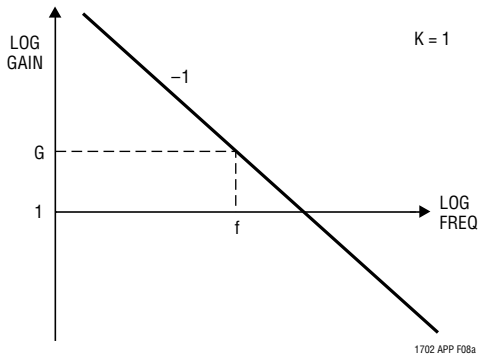

Figure A8a. Type 1 Amplifier

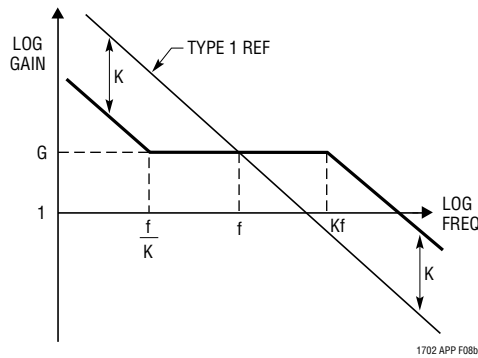

Figure A8b. Type 2 Amplifier

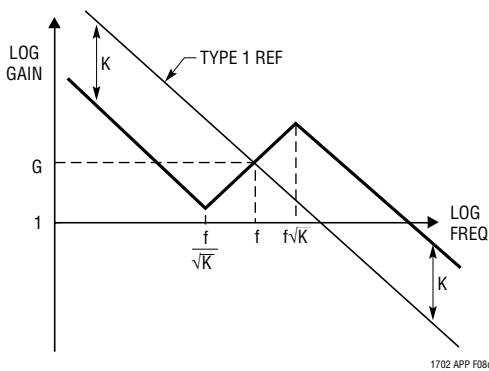

Figure A8c. Type 3 Amplifier

7.1 Derivation of K for Type 2 Amplifiers

The expression for the amount of phase boost from a zero-pole pair is well known and has been presented before. The phase shift due to a zero or pole is given by the inverse tangent of ratio of the measurement frequency to the frequency at which the zero or pole is located. The principle of superposition applies, that is, the total amount of phase shift can be determined by summing the individual phase shifts of each zero and pole taken individually. The boost at frequency f from a zero at frequency f/K and a pole at frequency Kf is given by the equation:

$$\text{Boost} = \text{Tan}^{-1}(K) - \text{Tan}^{-1}(1/K) \quad (1)$$

From the trigonometric identity,

$$\text{Tan}^{-1}(X) + \text{Tan}^{-1}(1/X) = 90 \text{ degrees} \quad (2)$$

the amount of boost can be determined by substituting (2) in (1):

$$\begin{aligned} \text{Boost} &= \text{Tan}^{-1}(K) + \text{Tan}^{-1}(K) - 90 \\ &= 2 \text{Tan}^{-1}(K) - 90 \end{aligned} \quad (3)$$

From equation (3),

$$\begin{aligned} \text{Tan}^{-1}(K) &= (\text{Boost} + 90)/2 \\ &= (\text{Boost}/2) + 45 \end{aligned} \quad (4)$$

Therefore:

$$K = \text{Tan}[(\text{Boost}/2) + 45] \quad (5)$$

Equation (5) is the equation that relates the K factor to the amount of phase boost required from Type 2 amplifiers to achieve the desired phase margin. From this, the exact location of the zeros and poles is established, and the loop cross-over frequency and phase margin may be calculated without trial-and-error.

7.2 Derivation K for Type 3 Amplifiers

Type 3 amplifiers have a double zero at a frequency f divided by the square root of K and a double pole at a frequency f times the square root of K . The phase boost from a single zero-pole pair at these frequencies is given by the equation:

$$\text{Boost} = \text{Tan}^{-1}\sqrt{K} - \text{Tan}^{-1}(1/\sqrt{K}) \quad (6)$$

Reference Reading # 4

For 2 zero-pole pairs, where the zeros are coincident and the poles are coincident, there is twice the boost that results from only 1 zero-pole pair, therefore the boost that results from a Type 3 amplifier is:

$$\text{Boost} = 2[\text{Tan}^{-1}\sqrt{K} - \text{Tan}^{-1}(1/\sqrt{K})] \quad (7)$$

Incorporating the trigonometric identity given in (2) into (7),

$$\begin{aligned} \text{Boost} &= 2(\text{Tan}^{-1}\sqrt{K} + \text{Tan}^{-1}\sqrt{K} - 90) \\ &= 2[2(\text{Tan}^{-1}\sqrt{K}) - 90] \\ &= 4(\text{Tan}^{-1}\sqrt{K}) - 180 \end{aligned} \quad (8)$$

Equation (8) can now be rearranged to solve for K:

$$\begin{aligned} \text{Tan}^{-1}\sqrt{K} &= (\text{Boost} + 180)/4 \\ &= (\text{Boost}/4) + 45 \end{aligned} \quad (9)$$

$$\sqrt{K} = \text{Tan} [(\text{Boost}/4) + 45] \quad (10)$$

$$K = \{\text{Tan}[(\text{Boost}/4) + 45]\}^2 \quad (11)$$

Equation (11) is the final equation expressing the K factor as a function of desired phase boost for a Type 3 amplifier. The location of the double zero and double pole is then established.

8. USING THE K FACTOR

8.1 Preliminary Steps

When using the K factor to synthesize an amplifier to stabilize a feedback loop, certain preliminary steps apply regardless of the type of amplifier chosen. These steps are as follows:

8.1.1 Make Bode Plots of the Modulator

This can be done by analysis or measurement, but preferably by measurement since it is difficult by analysis alone to include all the parasitic effects. Instruments to perform this measurement are called Frequency Response Analyzers. A number of companies manufacture this type of equipment. For switching regulators and similar applications where there is a significant amount of electrical noise present along with the signal, Fourier Integral Analysis machines are far superior to Fast Fourier Transform machines. Venable Industries offers several

different complete Frequency Response Analysis Systems, all based on Fourier Integral Analysis machines.

8.1.2 Choose a Cross-over Frequency

The second step in the process is to choose the frequency at which you would like the overall loop gain to be unity. This is f , the cross-over frequency. This is normally chosen to be as high as possible, since higher cross-over frequency normally means faster transient response, and “as high as possible” means where the modulator phase shift is still less than 180 degrees. If the circuit has to be built in volume, where there may be significant differences in component values from unit to unit, or if it will be subjected to wide extremes of line, load, and temperature, it is best not to push the loop to extremes.

8.1.3 Choose the Desired Phase Margin

Pick the amount of phase margin you would like to have at unity gain. A phase margin of 90 degrees means your system is stable as a rock. Phase margin of 60 degrees is a good compromise between fast transient response and stability. Phase margins of 30 degrees or less cause the system to have substantial ringing when subjected to transients, and little tolerance for component or environmental variations.

8.1.4 Determine Required Amplifier Gain

The fourth step is to determine the required amplifier gain at cross-over. The amplifier gain at cross-over must equal the modulator loss, therefore the amplifier gain = $1/\text{modulator gain}$. If the gain is expressed in dB, then the amplifier gain is simply the negative of the modulator gain.

8.1.5 Calculate Required Phase Boost

Calculate the amount of phase boost required from the zero-pole pair in the amplifier from the formula:

$$\text{Boost} = M - P - 90 \quad (12)$$

where M = Desired Phase Margin (degrees)
and P = Modulator Phase Shift (degrees)

8.1.6 Choose an Amplifier Type

Once the amount of boost required is determined, you can choose what type of amplifier to use.

Type 1 amplifier. The Type 1 amplifier is used where no boost is required. This is the case where a loop is crossed over before the frequency of the L-C corner, for example. This is the simplest type of amplifier and requires the fewest parts.

Type 2 amplifier. The Type 2 amplifier is used where the required boost is less than 90 degrees, and is most practical when the required boost is less than about 70 degrees, since a very large K factor is required as the boost approaches 90 degrees. It is used for loops where the modulator gain curve is falling off at about a -1 slope, and the phase shift is about -90 degrees. This is the case in current regulators, or in voltage regulators above the frequency of the ESR zero of the main filter capacitor.

Type 3 amplifier. The Type 3 amplifier is used where the required phase boost is less than 180 degrees. It offers the most boost for a given K factor of any of the amplifier types, but has the highest parts count also. A loop with a Type 3 amplifier will always perform better than one with a Type 1 or Type 2, where “better” is defined as more low frequency gain and less high frequency gain for a given cross-over frequency and amount of phase margin.

8.1.7 Choose a Value for R1

The final preliminary step is to choose a value for R1, the input resistor to the amplifier. This is normally based on how much current you want to draw from the modulator output. If the modulator is a low power, high voltage supply, R1 would typically be very large. If the modulator is a high power, low voltage supply, R1 can usually be selected arbitrarily. The current through R1 should be much larger than the input and bias currents of the operational amplifier used as an error amplifier. Care should be taken not to make the value of R1 too small, however, since all of the other compensation components scale in direct proportion to R1, and a low value for R1 means large values for the compensation capacitors. Large compensation capacitors, in addition to costing more, require more current to drive as a network, and may overload the output of the operational amplifier. A bias resistor, R_{BIAS}, is connected from the inverting input of the error amplifier to ground. This resistor is used to set the DC operating point of the loop, but has no effect on the ac operation, and does not enter into the calculations for cross-over frequency and phase margin.

8.2 Subsequent Steps

After the seven initial steps, the subsequent steps vary, depending on which type of amplifier you chose. In each case, the following notes and definitions apply:

- (1) Resistors are in ohms, capacitors are in farads, phase is in degrees, frequency is in hertz, gain is a dimensionless ratio (not dB), and K is a dimensionless ratio.
- (2) f = chosen cross-over frequency
- (3) G = Amplifier gain at cross-over
- (4) K = K factor
- (5) R and C values refer to components in the three basic amplifier schematics shown in Figures 5, 6, and 7.

8.2.1 Subsequent Steps - Type 1

The following equations apply to Type 1 amplifiers only:

$$K = 1 \quad (13)$$

$$C1 = 1/(2\pi f G R1) \quad (14)$$

A Type 1 amplifier is somewhat different from the others, in that there is no phase boost. For this reason, the phase margin of the overall loop with a Type 1 amplifier is 90 degrees, less whatever phase lag the modulator has at the chosen cross-over frequency.

8.2.2 Subsequent Steps - Type 2

The following equations apply to Type 2 amplifiers only:

$$K = \text{Tan}[(\text{Boost}/2) + 45] \quad (15)$$

$$C2 = 1/(2\pi f G K R1) \quad (16)$$

$$C1 = C2 (K^2 - 1) \quad (17)$$

$$R2 = K/(2\pi f C1) \quad (18)$$

This completes the synthesis of the Type 2 feedback amplifier. With these component values, the overall loop gain will be unity at frequency f, and the phase margin will be as specified, provided the required boost was between 0 and 90 degrees. It is worthwhile to verify that required amplifier gain at all frequencies is less than the open loop gain of the amplifier, since op amps are not truly ideal devices. Reactance-frequency graph paper is an excellent medium to use for this, since the verification can be done in a few moments and the results provide a better “feel” for the design.

Reference Reading # 4

8.2.3 Subsequent Steps - Type 3

The following equations apply to Type 3 amplifiers only:

$$K = \{\text{Tan}[(\text{Boost}/4) + 45]\}^2 \quad (19)$$

$$C2 = 1/(2\pi f G R1) \quad (20)$$

$$C1 = C2(K - 1) \quad (21)$$

$$R2 = \sqrt{K}/(2\pi f C1) \quad (22)$$

$$R3 = R1/(K - 1) \quad (23)$$

$$C3 = 1/(2\pi f \sqrt{K} R3) \quad (24)$$

This completes the synthesis of a Type 3 feedback amplifier. With these component values, the overall loop gain will be unity at frequency f , and the phase margin will be as specified, provided the required boost is between 0 and 180 degrees. It is worthwhile to verify that the required amplifier gain at all frequencies is less than the open loop gain of the amplifier, since op amps are not truly ideal devices. As with the Type 2 amplifier, reactance-frequency graph paper is an excellent medium to use for this.

8.3 Optimization

It is obvious that there is nothing that can be done to optimize a Type 1 amplifier, other than to choose the proper gain at a particular frequency. There is nothing that can be done to optimize a Type 2 amplifier either, although this may not be so obvious. With the K factor, the gain as well as the location of the zero and pole are determined for a particular operating point, and there is nothing you can do about the performance at other operating points other than live with what you get. It is the Type 3 amplifier that is intriguing, since the K factor assumptions are that the zeros and poles are coincident. What if the zeros and poles are not coincident? What if the zeros or poles or both are spread apart somewhat? Look at Figure 8c. For the same K factor, that is, the same penalty in low frequency gain, spreading the zeros or poles means flattening the sharp corners, moving one zero or pole toward cross-over frequency f , and the other zero or pole away. The net effect of this is to broaden and flatten the phase "bump", so that the phase margin at cross-over is reduced. Optimum performance, that is, the most phase margin for the

smallest K factor, is obtained when the zeros and poles are coincident. It may be the case, however, that a particular circuit may have wide excursions of line, load, and temperature, which lead to wide variations in the modulator transfer function. In special cases such as this, it may be advantageous to sacrifice optimum performance at a particular point, in order to gain satisfactory performance over a wide operating range.

9. SUMMARY

Three basic amplifiers were developed which can be used to stabilize any known feedback loop. A new mathematical tool, the K Factor, was developed, and a set of design equations were presented based on the K factor. These design equations allow the precise determination of loop performance without the iterative process normally associated with stability analysis. These techniques have been extensively tested at Venable Industries, and allow even a relatively unskilled person to stabilize a loop with remarkable accuracy and speed.

REFERENCES

- (1) Venable, H. Dean, "Practical Techniques for Analyzing, Measuring, and Stabilizing Feedback Control Loops in Switching Regulators and Converters", Proceedings of the Seventh National Power Conversion Conference, POWERCON 7, pp. I2-1 to I2-17, March, 1980.
- (2) Venable, H. Dean, "Stability Analysis Made Simple", Rancho Palos Verdes, CA, Venable Industries, 1982.
- (3) Middlebrook, R. D., and Cuk, Slobodan, "Advances in Switched-Mode Power Conversion, Volume I", Pasadena, CA TESLaco, 1981.
- (4) Cuk, Slobodan, and Middlebrook, R. D., "Advances in Switched-Mode Power Conversion, Volume II", Pasadena, CA, TESLaco, 1981.
- (5) Lee, F. C., and Yu, Y., "Application Handbook for a Standardized Control Module for DC-DC Converters", NASA Report Volume I and II, NAS3-20102, 1980.