

Verderflex VF125

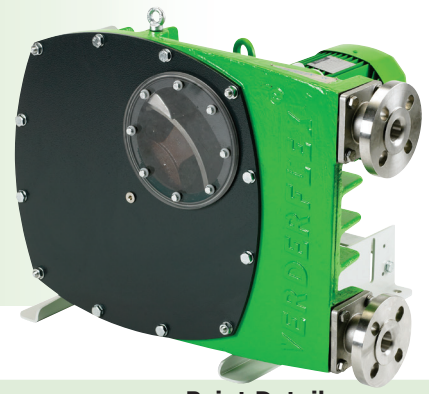

VERDERFLEX®

Description	Material	Paint Detail
Pump Housing	Cast Iron (GG25)	Green Powder Coated
Front Cover	Carbon Steel with Perspex Inspection Window	Powder Coated
Rotor	Cast Iron (GG25)	
Rotor Shoes	Aluminium (6082T6)	
Port Flange	316 Stainless Steel with sheradised steel flange to suit one of DIN PN16 or ANSI 150# or JIS10K	
Inserts	Stainless Steel (316L) Options: Polypropylene, PVDF Inserts	
Mounting Frame	Carbon Steel	Powder Coated
Lubricant	Verderlube - Glycerine based compound Verdersil - Silicone oil	
Hose	Natural Rubber (NR) Options: Nitrile Buna Rubber (NBR) Ethylene Propylene Diene Monomer (EPDM), and Hypalon® (CSM)	
Typical Pump Unit Weight	3075 - 3189 kg	

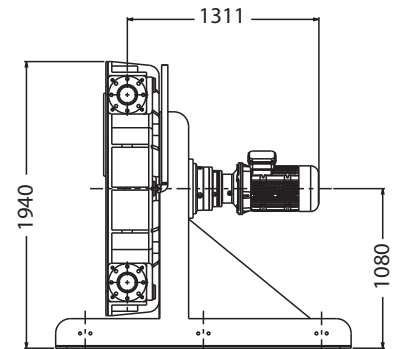
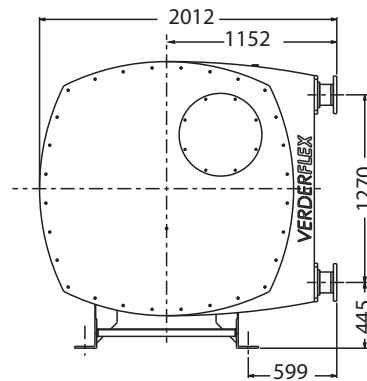
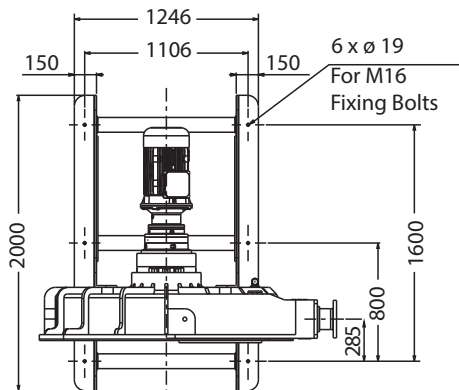

All dimensions are in mm.
All dimensions and weights are for guidance only.



Verderflex VF125

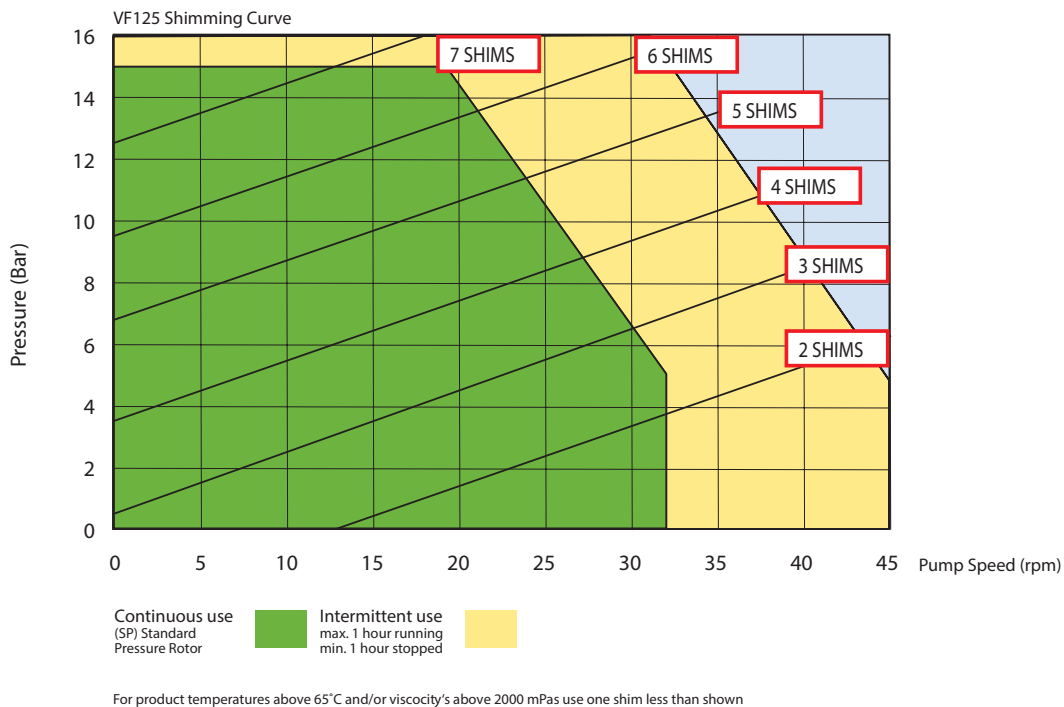
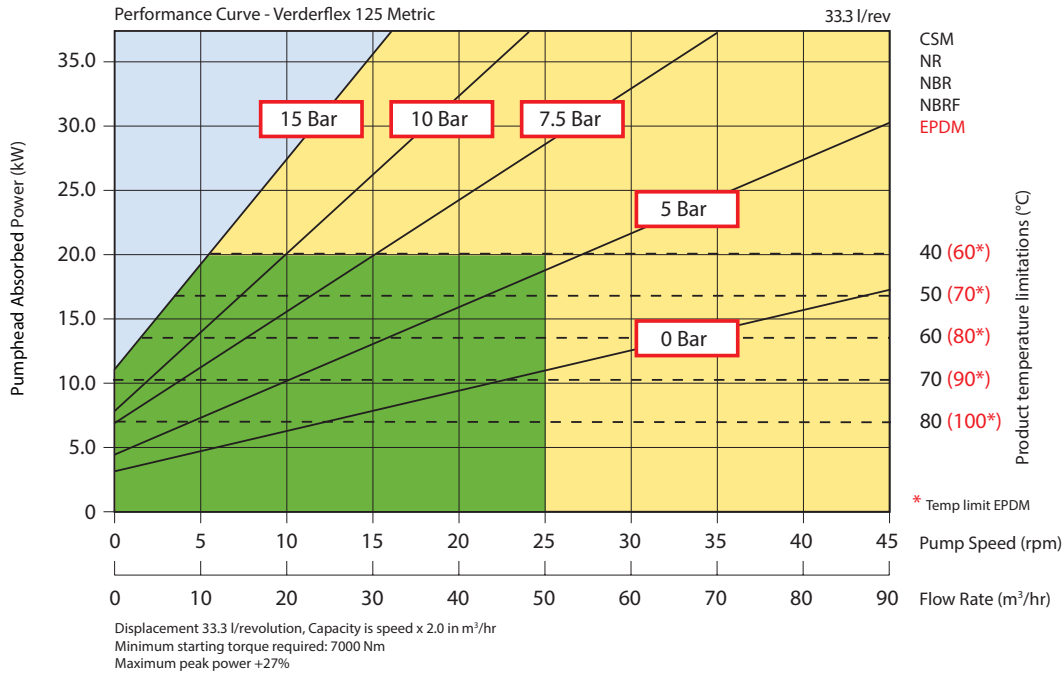

Flows are typical and were measured with water at 20°C with no suction lift or discharge pressure. Actual flows will vary according to suction conditions, discharge pressure and normal component production tolerances.

VF_Techno_Rev02_2013_(eu)_VF

**Find your local supplier
at www.verderflex.com**

For construction installation and floor mounting drawings
please contact your local authorised Verderflex® distributor.

VERDER
passion for pumps