

LED lighting for light industrial areas  
IHB series high bay LED luminaires

CROUSE-HINDS  
SERIES

# IHB series

High bay LED luminaires for light industrial areas

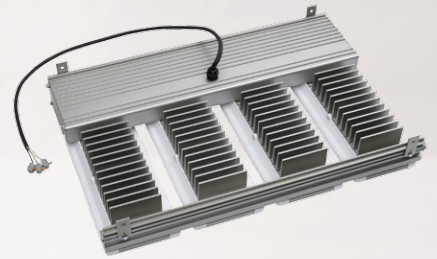

**EATON**

Powering Business Worldwide



IHB series high bay LEDs

# Safe. Reliable. Efficient.

Featuring the industry's broadest range of LED luminaires for harsh, hazardous and industrial environments, Eaton's Crouse-Hinds can deliver a lighting solution that performs reliably in even the worst operating conditions. All the while reducing your energy, maintenance and manpower costs.

## Why LED?

### Useful life

Rated life is up to 60,000 hours of maintenance-free and safe operation

### Energy efficiency

LED average energy consumption is significantly less than traditional fluorescent and HID fixtures

### Start/restart time

Instant illumination vs. 10 minute restrike time for HID

### Light quality

Higher color rendering compared to fluorescent and HID

### Environmental benefits

Mercury-free LED eliminates disposal costs and lower energy consumption for a smaller carbon footprint

## Why Crouse-Hinds?

### Industry-best reliability

Built to withstand a wide array of applications

### Thermal management

Effective heat sinking ensures longer life

### Quality of light

Custom optics designed to maximize light distribution and intensity

### Versatile mounting

Slim profile with three mounting configurations for easy installation

# Why IHB series LED?

**Reliable high bay solutions.** IHB series LED luminaires are engineered to provide maintenance-free performance while delivering long life and high lumen performance.



**Increased efficiency and durability:**

- Up to 117 lumens per watt
- Up to 67% energy savings over traditional HID fixtures

**Multiple lens options:**

- Tempered, clear glass lens standard
- Diffused glass and clear or diffused polycarbonate lens options available



IHB16L



IHB32L



**Superior thermal management:**

- Aluminum heat sinks designed to provide long life performance

**Full portfolio of high bay solutions:**

- Complete portfolio replaces 250W-1,500W+ HID and 2-10 lamp T8, T12 and T5HO fluorescent lamps

## LED vs. HID savings at a glance

Why are so many facilities making the switch from HID to LED?

The numbers say it all.

### IHB16L/UNV1 vs. 400 watt HID

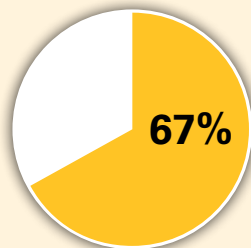

67% REDUCTION IN ENERGY COSTS

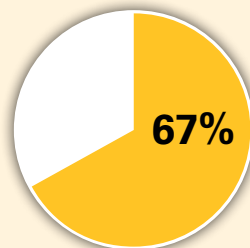

67% LOWER TOTAL COST OF OWNERSHIP



100% MAINTENANCE REDUCTION

Assumptions: Calculations based on overall life of the LED system. Energy cost of \$.09 per kilowatt; 24 hour per day operation; labor rate of \$75 each for 2 workers; average time for fixture maintenance of 1 hour.

## IHB series high bay LED Luminaires

IHB series LED luminaires are the perfect replacement for 250W-1,500W+ HID and 2-10 lamp T8, T12 and T5HO fluorescent high bay fixtures. Designed for locations requiring continuous and consistent light levels, requiring frequent on-and-off of lights and that are difficult to re-lamp.

### Applications:

- Locations requiring continuous and consistent light levels
- Areas requiring frequent on-and-off of lights
- Areas that are difficult to re-lamp or that cause production to be stopped during the lamp maintenance process
- Ordinary clean, light industrial production facilities, packaging facilities and warehouses

### Key features & benefits:

- High efficacy: up to 117 LPW
- 80 CRI
- Up to 67% energy savings over traditional HID fixtures
- Complete portfolio replaces 250W-1,500W+ HID and 2-8 lamp T8, T12 and T5HO fluorescent lamps
- Customer payback of 1-3 years and lower total cost of ownership compared to HID and fluorescent lighting
- Versatile mounting options
- Optional 0-10V dimming capabilities
- Damp location rated
- Operating ambient: -40°C to +60°C\*
- 5 year fixture warranty†

\*5 year warranty at 40°C average operating ambient temperature

†Refer to page 2 of the D-0914 authorized distributor price book for Crouse-Hinds standard Terms and Conditions

### Energy savings:

Up to 67% energy savings vs. HID

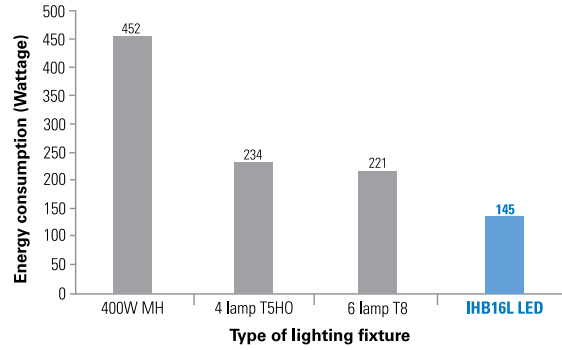

### Economic life without dust cover:

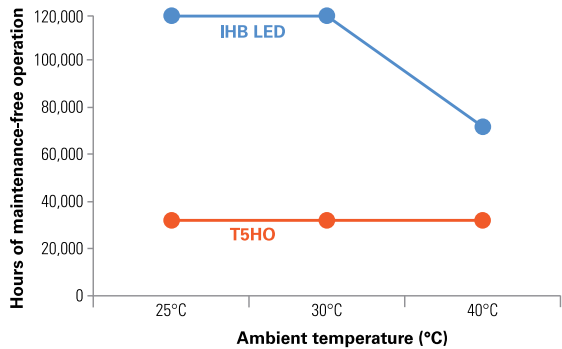

Economic life can range anywhere between 60,000 hours @ 40°C to 120,000+ hours @ 25°C or 5 to 10 years of maintenance-free operation. L70 > 140,000 hours @ 60°C and > 200,000 hours at 40°C.

\* 10,000 hr. life reduction with DC1 dust covers  
5,000 hr. life reduction with DC2 dust covers.

### Warehouse retrofit: HID to LED

A warehouse was retrofit with 42 IHB series LED luminaires to replace existing HID lighting. The company immediately saw over \$300 per month savings on electricity and essentially eliminated lamp maintenance.

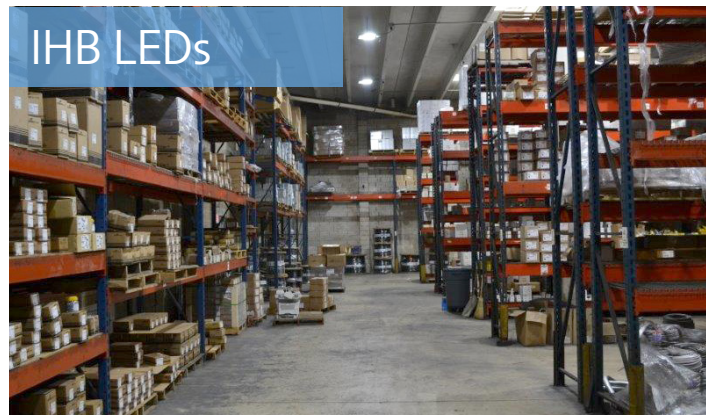



**Certifications:**

- UL1598 Luminaires
- UL8750 LED
- cULus
- Damp location
- DesignLights Consortium® Qualified (some models are not DLC qualified)\*



\* Approved models include: IHB16L/UNV1; IHB16L/UNV34; IHB24L/UNV1; IHB24L/UNV34; IHB32L/UNV1; IHB32L/UNV34; IHB48L/UNV1; IHB48L/UNV34; IHB64L/UNV1; IHB64L/UNV34. Refer to www.designlights.org Qualified Products List under Family Models for full listing details. Not all models are approved for all application categories.

**Materials:**

**Housing and heat sinks:**

- Anodized aluminum

**LED assembly:**

- Assembly – polycarbonate
- Lens – tempered glass or polycarbonate

**Mounting:**

- ¾" pendant mount
- Jack chain
- Aircraft cable

**Weights:**

Luminaire	lbs.	kg.
IHB16L	17	7.71
IHB24L	27	12.25
IHB32L	36	16.33
IHB48L	54	24.49
IHB64L	74	33.57

**Electrical specifications:**

Model	Equivalent luminaires		Voltage	@ 120V				
	HID	Fluorescent		PF	THD	Wattage	Lumen†	Efficacy
IHB16L	250-500W	4 lamp T5HO	120	.99	8%	145	16,900	117
IHB24L	400-750W	4-6 lamp T5HO	120	.99	7%	216	25,350	117
IHB32L	500-1,000W	6-8 lamp T5HO	120	.99	8%	289	33,800	117
IHB48L	750-1,500W	8-10 lamp T5HO	120	.99	8%	436	50,700	116
IHB64L	1,000-1,500W+	10 lamp T5HO	120	.99	8%	582	67,600	116

†Preliminary typical values (+/- 10%); data subject to change. 8L option available; consult product line for availability.

**Dimensions:**

**IHB16L**

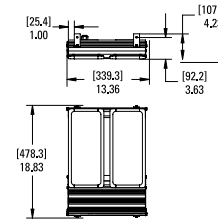

**IHB24L**

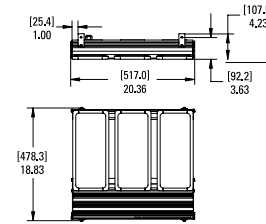

**IHB32L**

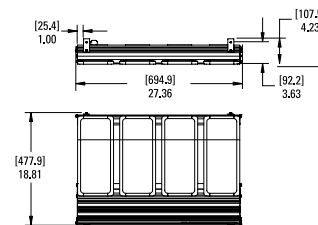

**IHB48L**

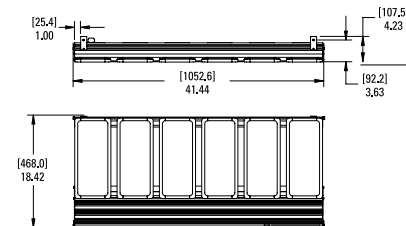

**IHB64L**

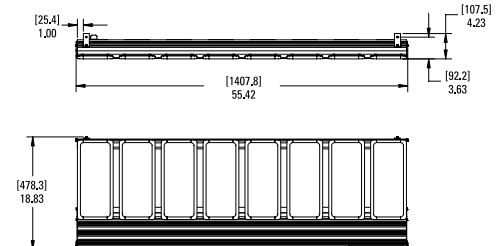

# Ordering information

## Part number example

### IHB16LP1R1 /UNV1 S903

IHB series high bay LED, 16,900 lumens, 145 watts, cool white, ¾" pendant mount, aisle optics, 100-277 VAC/127-250 VDC driver, polycarbonate lens

Series		Mounting		Voltage @ 50/60 Hz		Options	
IHB	IHB series light industrial high bay fixture	BLANK	No mount	/UNV1	100-277 VAC; 127-250 VDC	BLANK	Glass lens
<b>Lumens/watts*</b>		P1*	¾" pendant mount kit (8L-32L models)	/UNV34	347-480 VAC	S891	Diffused glass lens
8L**	8,450 lumens, 71 watts	P2*	¾" pendant mount kit (48L-64L models)	/UNV1D	Dimmable; 100-277 VAC; 127-250 VDC	S903	Polycarbonate lens
16L	16,900 lumens, 145 watts	* Not for use with dust covers. Order dust cover and matching pendant mount separately.		/UNV34D	Dimmable; 347-480 VAC	S903D	Diffused polycarbonate lens
24L	25,350 lumens, 216 watts					SO10	10 ft. SO cable
32L	33,800 lumens, 289 watts					CE	IEC certified
48L	50,700 lumens, 436 watts					<b>Optics</b>	
64L	67,600 lumens, 582 watts					BLANK	Wide optic
*Typical values (+/- 10%); data subject to change						R1	Aisle optic
**8L option available; consult product line for availability							
<b>Color temperature</b>							
BLANK	Cool white						

## Accessories:

### Mounting kits (ordered separately)

IHB P1 KIT	¾" pendant mount kit (8L-32L models)
IHB P2 KIT	¾" pendant mount kit (48L-64L models)
IHB P3 KIT	¾" pendant mount kit for use with dust cover (8L-32L models)
IHB P4 KIT	¾" pendant mount kit for use with dust cover (48L-64L models)
IHB J1 KIT	48" jack chain kit
IHB J2 KIT	72" jack chain kit
IHB J3 KIT	96" jack chain kit
IHB J4 KIT	120" jack chain kit
IHB J5 KIT	144" jack chain kit
IHB A1 KIT	40" aircraft cable kit
IHB A2 KIT	80" aircraft cable kit
IHB A3 KIT	120" aircraft cable kit
IHB A4 KIT	180" aircraft cable kit

### Dust cover kits (ordered separately)

IHB8L DC1 KIT	IHB8L dust cover kit, fully enclosed (1.2 lbs.)
IHB16L DC1 KIT	IHB16L dust cover kit, fully enclosed (1.6 lbs.)
IHB24L DC1 KIT	IHB24L dust cover kit, fully enclosed (2.5 lbs.)
IHB32L DC1 KIT	IHB32L dust cover kit, fully enclosed (3.3 lbs.)
IHB48L DC1 KIT	IHB48L dust cover kit, fully enclosed (5.0 lbs.)
IHB64L DC1 KIT	IHB64L dust cover kit, fully enclosed (6.4 lbs.)
IHB8L DC2 KIT	IHB8L dust cover kit, open ended (2.4 lbs.)
IHB16L DC2 KIT	IHB16L dust cover kit, open ended (2.7 lbs.)
IHB24L DC2 KIT	IHB24L dust cover kit, open ended (3.4 lbs.)
IHB32L DC2 KIT	IHB32L dust cover kit, open ended (4.1 lbs.)
IHB48L DC2 KIT	IHB48L dust cover kit, open ended (6.8 lbs.)
IHB64L DC2 KIT	IHB64L dust cover kit, open ended (8.6 lbs.)

### Replacement drivers (ordered separately)

#### 100-277 VAC; 127-250 VDC

IHB UNV1D 75W DRIVER KIT*	Dimmable, 75W replacement driver
IHB UNV1D 150W DRIVER KIT**	Dimmable, 150W replacement driver

\*8L and 24L models; \*\*16L, 24L, 32L, 48L and 64L models  
(24L model uses a single 75W and a single 150W driver)

#### 347-480 VAC

IHB UNV34D 75W DRIVER KIT*	Dimmable, 75W replacement driver
IHB UNV34D 150W DRIVER KIT**	Dimmable, 150W replacement driver

\*8L and 24L models; \*\*16L, 24L, 32L, 48L and 64L models  
(24L model uses a single 75W and a single 150W driver)

### Occupancy sensors (ordered separately)

Kit	Sensor lens	Mounting height (ft.)	Max. coverage diameter (ft.)	Light fixture
IHB C1 KIT*	FSP-L2	8	48	8L
IHB C2 KIT*	FSP-L3	20	40	16L, 24L, 32L, 48L, 64L
IHB C3 KIT*	FSP-L4	40	60	48L, 64L
IHB C4 KIT*	FSP-L7	40	100	49L, 64L

\*Consult factory or customer service for 347-480 VAC occupancy sensors

REMOTE CONTROL 1	Occupancy sensor remote control
------------------	---------------------------------

### Lens guard (ordered separately)

IHB G KIT	Lens guard (specify quantity, order one guard per 8L module, see table below)
-----------	---

Model	quantity	Model	quantity
IHB8L	1	IHB32L	4
IHB16L	2	IHB48L	6
IHB24L	3	IHB64L	8

# Mounting options and accessories

## Mounting options:

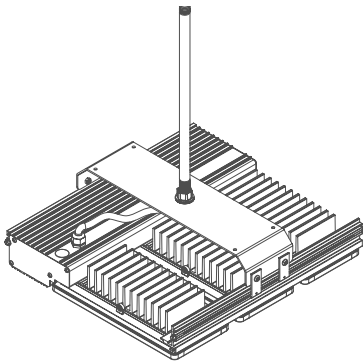

### Pendant mount

- P1 and P2 for use without dust cover. Can be ordered separately or factory installed
- P3 and P4 for use with dust cover

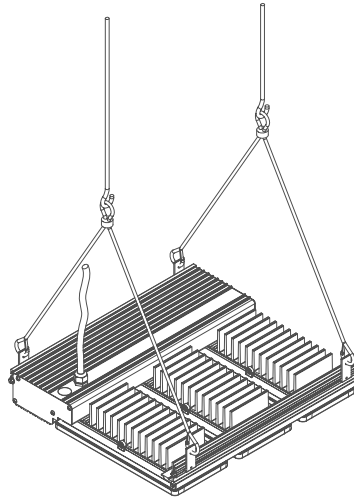

### Aircraft cable

- Ships separately from fixture
- For mounting with or without dust cover

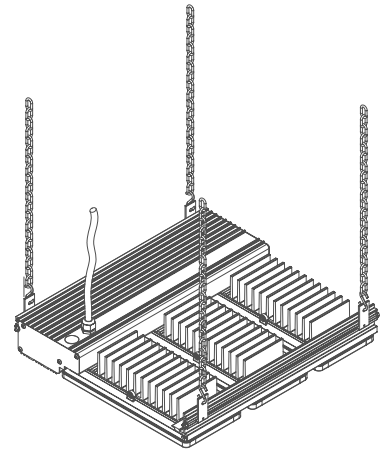

### Jack chain

- Ships separately from fixture
- For mounting with or without dust cover

## Accessories:

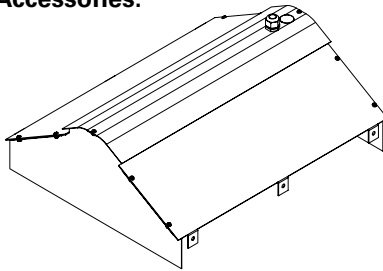

**DC-1**  
Fully enclosed dust cover

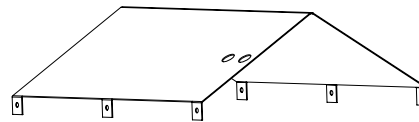

**DC-2**  
Open ended dust cover

### Dust covers

- Ships separately from fixture
- For pendant mount use IHB P3 KIT (8L\_32L models); IHB P4 KIT (48L-64L models)

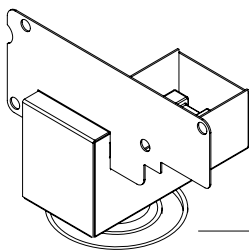

**IHB CX KIT**  
Occupancy sensor

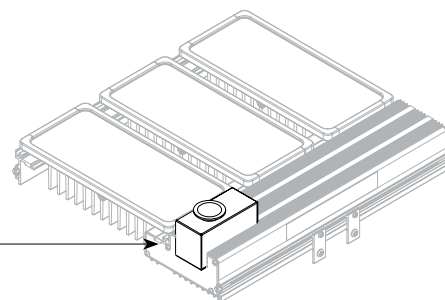

### Occupancy sensor and remote

- Ships separately from fixture; installation required
- Photocell and occupancy sensor customizable with remote control
- Remote control sold separately. Only one required to program multiple light fixtures

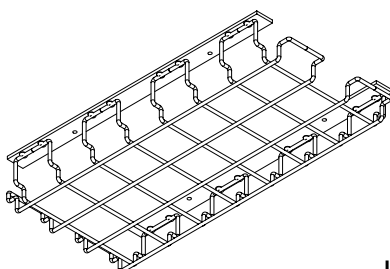

**IHB G KIT**  
Lens guard

### Lens guards

- Ships separately from fixture
- Order quantity differs by model

Model	quantity
IHB8L	1
IHB16L	2
IHB24L	3

Model	quantity
IHB32L	4
IHB48L	6
IHB64L	8

**U.S. (global headquarters):  
Eaton's Crouse-Hinds business**

1201 Wolf Street  
Syracuse, NY 13208

(866) 764-5454  
FAX: (315) 477-5179  
FAX Orders Only:  
(866) 653-0640

[crousecustomerctr@eaton.com](mailto:crousecustomerctr@eaton.com)

**For more information:**

If further assistance is required, please contact an authorized Eaton Distributor, Sales Office, or Customer Service Department.

**Canada**

Toll Free: 800-265-0502  
FAX: (800) 263-9504  
FAX Orders only: (866) 653-0645

**Mexico/Latin America/Caribbean**

52-555-804-4000  
FAX: 52-555-804-4020  
[ventascentromex@eaton.com](mailto:ventascentromex@eaton.com)

**Europe (Germany)**

49 (0) 6271 806-500  
49 (0) 6271 806-476  
[sales.CCH.de@cooperindustries.com](mailto:sales.CCH.de@cooperindustries.com)

**Eaton Middle East**

9714-8066100  
FAX: 9714-8894813  
[chmesales@eaton.com](mailto:chmesales@eaton.com)

**Singapore**

65-6645-9888  
FAX: 65-6297-4819  
[chsi-sales@cooperindustries.com](mailto:chsi-sales@cooperindustries.com)

**China**

86-21-2899-3600  
FAX: 86-21-2899-4055  
[cchsales@cooperindustries.com](mailto:cchsales@cooperindustries.com)

**Korea**

82-2-3484-6783  
82-2-3484-6778  
[CCHK-sales@cooperindustries.com](mailto:CCHK-sales@cooperindustries.com)

**Australia**

61-2-8787-2777  
FAX: 61-2-9609-2342  
[CEASales@cooperindustries.com](mailto:CEASales@cooperindustries.com)

**India**

91-124-4683888  
FAX: 91-124-4683899  
[cchindia@eaton.com](mailto:cchindia@eaton.com)

**Eaton**  
1000 Eaton Boulevard  
Cleveland, OH 44122  
United States  
[Eaton.com](http://Eaton.com)

© 2017 Eaton  
All Rights Reserved  
Printed in USA  
Publication No. 5162-0517  
May 2017

Eaton is a registered trademark.  
All other trademarks are property of their respective owners.