



Date: _____ Truck#: _____ Operator: _____

Start Hour: _____ End Hour: _____ Fuel: _____

ELECTRIC TRUCK DAILY CHECK LIST

Indicate an **X** where a problem is detected and a **✓** to indicate no problems visible.

Visual Inspection

COMMENTS

1. Battery _____
 Vent Caps _____
 Connector Covers _____
 Cables _____
2. Overhead Guard _____
3. Front Tire (Left) _____
4. Tilt Cylinder _____
5. Carriage _____
6. Fork Locking Pin (Left) _____
7. Fork (Left) _____
 (Attachment Applicable) _____
8. Mast _____
9. Lift Cylinder _____
 Lift Chains _____
10. Fork (Right) _____
 (Attachment Applicable) _____
11. Fork Locking Pin (Right) _____
12. Carriage _____
13. Tilt Cylinder _____
14. Front Tire (Right) _____
15. Hydraulic Oil _____
16. Data Plate _____
17. Battery Connectors _____
18. Seat & Seat Belt _____
19. Operator Manual _____
20. Rear Tire (Right) _____
21. Rear Tire (Left) _____

All comments made in reference to any problems should be made on the back of this page in detail and handed to the supervisor immediately.

SIGNATURE:

Operational Inspection

COMMENTS

- A. Listen for Unusual Noise _____
- B. Check Service & Parking Brake _____
- C. Lifting Control _____
- D. Tilt Control _____
- E. Forward Driving _____
 Accelerator _____
 Steering _____
 Braking _____
- F. Reverse Driving _____
 Accelerator _____
 Steering _____
 Braking _____
 Backup Alarm _____
- G. Lights _____
- H. Horn _____
- I. Gauges _____
- J. Oil Spots on Floor _____

WALK AROUND

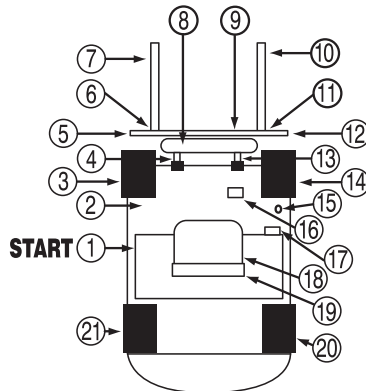

CAUTION: This is not a complete list of all items which may require attention. Operators are responsible for ensuring that the lift truck is in proper working condition in accordance with the manufacturer's specifications.

DO NOT operate lift truck if a problem is detected. Report all problems to the service department immediately.

TO BE COMPLETED BY DESIGNATED OPERATOR AND FORWARDED TO SUPERVISOR PRIOR TO SHIFT.