



Date: _____ Truck#: _____ Operator: _____
 Start Hour: _____ End Hour: _____ Fuel: _____

NARROW AISLE LIFT TRUCK CHECK LIST

Indicate an **X** where a problem is detected and a **✓** to indicate no problems visible.

Visual Inspection	COMMENTS
1. <input type="checkbox"/> Battery _____ <input type="checkbox"/> Vent Caps _____ <input type="checkbox"/> Connector Covers _____ <input type="checkbox"/> Cables _____	
2. <input type="checkbox"/> Load Wheel _____	
3. <input type="checkbox"/> Overhead Guard _____	
4. <input type="checkbox"/> Tilt Cylinder _____	
5. <input type="checkbox"/> Carriage _____	
6. <input type="checkbox"/> Forks _____	
7. <input type="checkbox"/> Mast _____	
8. <input type="checkbox"/> Cylinder Lift _____ <input type="checkbox"/> (Tilt and Reach if Applicable) _____	
9. <input type="checkbox"/> Lift Chains _____	
10. <input type="checkbox"/> Nameplate _____	
11. <input type="checkbox"/> Battery Retainer Plate _____	
12. <input type="checkbox"/> Drive/Steer Tire _____	

Operational Inspection	COMMENTS
A. <input type="checkbox"/> Listen for Unusual Noise _____	
B. <input type="checkbox"/> Parking Brake _____	
C. <input type="checkbox"/> Lifting Control _____	
D. <input type="checkbox"/> Tilt Control _____	
E. <input type="checkbox"/> Forward Driving _____ <input type="checkbox"/> Steering _____ <input type="checkbox"/> Braking _____	
F. <input type="checkbox"/> Reverse Driving _____ <input type="checkbox"/> Steering _____ <input type="checkbox"/> Braking _____ <input type="checkbox"/> Backup Alarm (Optional) _____	
G. <input type="checkbox"/> Lights _____	
H. <input type="checkbox"/> Horn _____	
I. <input type="checkbox"/> Gauges _____	
J. <input type="checkbox"/> Oil Spots on Floor _____	

All comments made in reference to any problems should be made on the back of this page in detail and handed to the supervisor immediately.

SIGNATURE:

Order Picker WALK AROUND

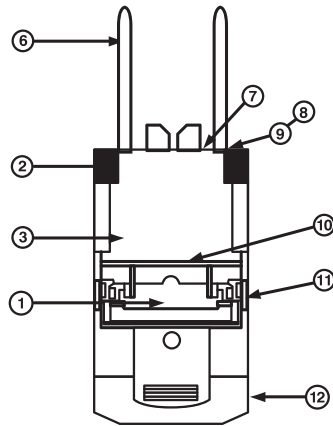

Reach Truck WALK AROUND

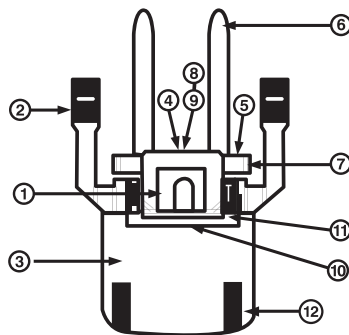

CAUTION: This is not a complete list of all items which may require attention. Operators are responsible for ensuring that the lift truck is in proper working condition in accordance with the manufacturer's specifications.

DO NOT operate lift truck if a problem is detected. Report all problems to the service department immediately.

TO BE COMPLETED BY DESIGNATED OPERATOR AND FORWARDED TO SUPERVISOR PRIOR TO SHIFT.